

SPRING LOADED GATE CASTERS

GATE & LADDER CASTERS

Load Capacity Up to 210 lbs.



Custom Gate & Ladder Casters Available in Stainless Steel with Nylacron™ Wheels

These casters are designed to make gate opening and closing easy. The casters feature gate mounts and spring loaded shock absorption.

Features

- Gate mount integrated in caster
- Spring loaded design provides shock absorption

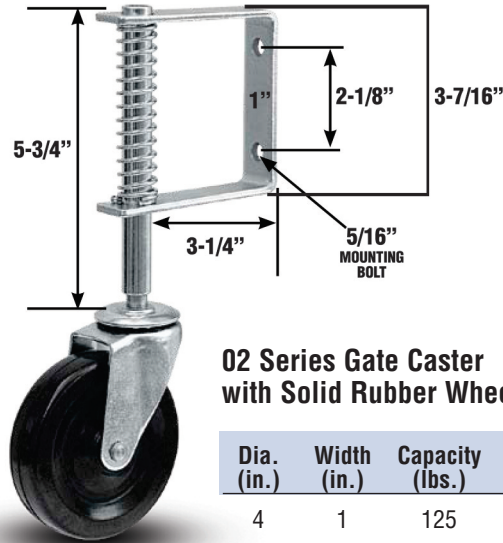

02 Series Gate Caster with Solid Rubber Wheel (41 Plain Bearing)

Dia. (in.)	Width (in.)	Capacity (lbs.)	OAH (in.)	Swivel Lead (in.)	Part Number
4	1	125	10-1/2	3.2	02RN04041S007



14 Series Gate Caster with Semi-Pneumatic Tire (27 Radial Ball Bearing)

Dia. (in.)	Width (in.)	Capacity (lbs.)	OAH (in.)	Swivel Lead (in.)	Part Number
8	2-1/2	210	18-1/2	6.5	14SN08427S001