

# V-GROOVE CASTERS

Designed for use on inverted angle track for any service requiring guidance of the truck or conveyor unit. Suggested uses include movement of production jigs or fixtures in straight line assembly, travel in and out of “blind alley” retorts or ovens, and in assembly or processing operations where rivets, bolts or other wheel stopping hazards might impede normal movement.

## V-GROOVE CASTER FEATURES

- Complete flexibility either on the floor or track.
- Wheel face and “V” groove fully machined.
- Wheel Bearings - straight roller, with hardened and precision ground spanner bushing inner race for medium to heavy duty service. Tapered roller bearings for heavier duty or more rugged applications.
- Lubrication - full pressure type to all bearings.
- Finish - Rigs thru Series 90 are plated Series 94 and 95 rigs and all wheels are finished in aluminum enamel.

**OPTIONAL FEATURES AVAILABLE:**  
See appropriate caster series

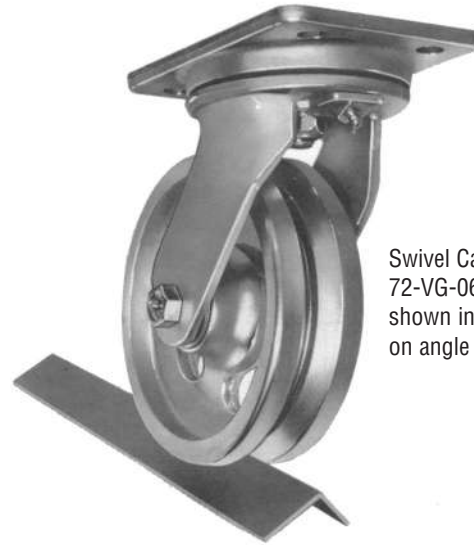
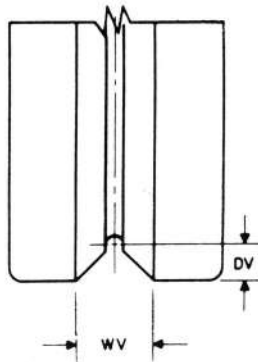

Swivel Caster Model 72-VG-062001-S shown in position on angle iron track

## NYLACRON™ Wheels Available



95-VH-10709-R rigid caster with 10 x 4 V-Groove wheel 15,000 pound rating

### Caster Height and Top Plate Mounting Dimensions

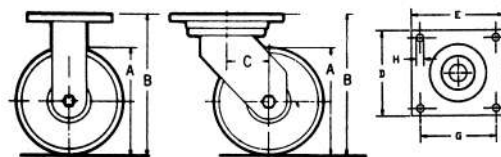

# V-GROOVE CASTERS

## V-GROOVE CASTER SPECIFICATIONS with CAST IRON WHEELS

Dia. (inch)	Width (inch)	Cap. (R Brg)	Cap. (T Brg)	OAH (inch)	Hub Length (inch)	Swivel Lead (inch)	Bolt Hole Centers (inch)	Top Plate (inch)	Wt. (lbs.)	Part Number Roller Brg	Part Number Tapered Brg
4	1-3/4	800	-	5-5/8	2-3/16	1-7/16	2-5/8 x 3-5/8	4 x 4-1/2	7-1/2	16VGR04201	-
4	1-3/4	800	-	5-5/8	2-3/16	1-5/16	3-3/8 x 5-1/4	4-1/2 x 6-1/4	9-1/4	62VGR04201	-
4	1-3/4	800	-	5-5/8	2-3/16	1-7/16	2-5/8 x 3-5/8	4-1/2 x 6-1/4	9	71VGR04201	-
4	1-3/4	800	-	5-5/8	2-3/16	1-7/16	2-7/16 x 4-15/16	4-1/2 x 6-1/4	10-1/2	72VGR04201	-
5	2	800	-	6-1/2	2-3/16	1-5/8	2-5/8 x 3-5/8	4 x 4-1/2	8-1/2	16VGR05201	-
5	2	800	-	6-1/2	2-3/16	1-1/2	3-3/8 x 5-1/4	4-1/2 x 6-1/4	10-1/4	62VGR05201	-
5	2	800	-	6-1/2	2-3/16	1-13/16	2-5/8 x 3-5/8	4-1/2 x 6-1/4	10	71VGR05201	-
5	2	800	-	6-1/2	2-3/16	1-13/16	2-7/16 x 4-15/16	4 x 6	11-1/2	72VGR05201	-
6	2	900	-	7-1/4	2-3/16	1-3/4	2-5/8 x 3-5/8	4 x 4-1/2	11-3/4	16VGR06201	-
6	2	1000	-	7-1/2	2-3/16	1-3/4	2-7/16 x 4-15/16	4-1/2 x 6-1/4	13-1/2	62VGR06201	-
6	2	1000	-	7-1/2	2-3/16	2-1/4	2-5/8 x 3-5/8	4 x 5	13-1/4	71VGR06201	-
6	2	1000	-	7-1/2	2-3/16	2-1/4	2-5/8 x 4-7/8	4 x 6	14-3/4	72VGR06201	-
6	2-1/2	2000	2000	7-5/8	3-1/4	1-1/2	3-3/8 x 5-1/4	4-1/2 x 6-1/4	21-3/4	81VGR06401	81VGR06409
6	2-1/2	2500	2500	8	3-1/4	2-1/4	3-3/8 x 5-1/4	5-1/4 x 7-1/4	26-1/4	90VGR-06401	90VGR06409
8	2-1/2	2000	2000	10-1/8	3-1/4	2-1/4	3-3/8 x 5-1/4	4-1/2 x 6-1/4	26-1/4	81VGR08401	81VGR08409
8	3	2500	2500	10-1/2	3-1/4	2-1/2	3-3/8 x 5-1/4	5-1/4 x 7-1/4	31-3/4	90VGR08401	90VGR08409
8	3	4000	4000	10-1/2	3-1/4	2-1/2	4-1/2 x 6	6-1/2 x 7-1/2	42-3/4	94VGR08501	90VGR08509
10	3	3000	3500	12-1/2	3-1/4	2-1/2	3-3/8 x 5-1/4	5 x 7-1/4	42-1/2	90VGR10501	90VGR10509
10	3	3000	3500	12-1/2	3-1/4	2-1/2	3-3/8 x 5-1/4	5 x 7-1/4	42-1/2	90VGR10501	90VGR10509
10	3	4000	4000	12-1/2	3-1/4	2-1/2	4-1/2 x 6	6-1/2 x 7-1/2	53-1/2	94VGR10501	90VGR10509
								6 x 7-1/2			

\*Add "B" for Ball Bearing, "P" for Precision Bearing, "PL" for Plain Bearing, "R" for Roller Bearing or "T" for Tapered Bearing.

All Rig Options should be added to the end of the part number. (i.e. 72DW-PB-R\*-0415-SL for Swivel Lock)

See Wheel Section for other premium wheels.

## V-GROOVE CASTER SPECIFICATIONS with DROP FORGED WHEELS

Dia. (inch)	Width (inch)	Cap. (R Brg)	Cap. (T Brg)	OAH (inch)	Hub Length (inch)	Swivel Lead (inch)	Bolt Hole Centers (inch)	Top Plate (inch)	Wt. (lbs.)	Part Number Roller Brg	Part Number Tapered Brg
6	3	6000	6500	8-1/2	3-1/4	2-1/2	4-1/2 x 6	6-1/2 x 7-1/2 6 x 7-1/2	45	94VFR06501	94VFR06509
6	3	6000	10000	9	3-1/4	2-1/4	7 x 7	8-1/2 x 8-1/2	59-1/2	95VFR06501	95VHR06509
8	4	8350	10000	10-1/2	4-1/4	2-1/2	4-1/2 x 6	6-1/2 x 7-1/2 6 x 7-1/2	47	94VFR08701	94VFR08709
8	4	8350	15000	11	4-1/4	2-1/4	7 x 7	8-1/2 x 8-1/2	61-1/2	95VFR08701	95VHR08709
10	3	6000	6000	12-1/2	3-1/4	2-1/2	4-1/2 x 6	6-1/2 x 7-1/2	63	94VHR10501	94VHR10509
10	4	8350	10000	12-1/2	4-1/4	2-1/2	4-1/2 x 6	6-1/2 x 7-1/2	73-3/4	94VFR10701	94VFR10709
10	3	6000	6000	13	3-1/4	2-1/2	7 x 7	8-1/2 x 8-1/2	67-3/4	95VHR10501	95VHR10509
10	4	8350	15000	13	4-1/4	2-1/4	7 x 7	8-1/2 x 8-1/2	89-1/2	95VFR10701	95VHR10709

\*Add "B" for Ball Bearing, "P" for Precision Bearing, "PL" for Plain Bearing, "R" for Roller Bearing or "T" for Tapered Bearing

All Rig Options should be added to the end of the part number. (i.e. 72DW-PB-R\*-0415-SL for Swivel Lock)

See Wheel Section for other premium wheels

**ALL V-GROOVE CASTERS ARE NOW AVAILABLE IN KINGPINLESS CONSTRUCTION  
WITH NYLACRON™ PRECISION BEARING WHEELS**