

LEVELING CASTERS



- Built-in stabilizer is adjustable.
- Rubber stabilizer “post” helps adsorb shaking and shock.
- Excellent low-profile caster for workstations that only occasionally move.
- Stabilizer acts as a miniature “lock” when fully engaged to prevent caster from moving.
- Strong nylon wheel is non-marking.
- Double race swivel design.
- Available in top plate and stemless fastenings.
- Corrosion resistant zinc plated finishing, sleek chrome plating or ivory powder coating for extra style.
- Extra load capacity with stabilizer engaged.
- Applications include:
 - Computer workstations
 - Work tables
 - Printer and electronic stands

Wheel Dia.	Hub Length	Wheel Type with Plain Bearing	Capacity (lb.) Rolling / Stabilized	OAH	Swivel Lead	Part Number	Type
1-3/4"	1-1/16"	NYL-Nylon	220 / 550	2-3/4"	2-13/32"	932000NYL	Stemless
1-3/4"	1-1/16"	NYL-Nylon	220 / 550	2-3/4"	2-13/32"	932001NYL	Square Plate
1-3/4"	1-1/16"	NYL-Nylon	220 / 550	2-3/4"	2-13/32"	932002NYL	Hexagon Plate
2-1/2"	1-3/8"	NYL-Nylon	320 / 1,000	4-1/32"	3-3/32"	933000NYL	Stemless
2-1/2"	1-3/8"	NYL-Nylon	320 / 1,000	4-1/32"	3-3/32"	933001NYL	Square Plate

Dia.	Type	Size	Code
1-3/4"	Stemless	M12 x 1.75P Tap Depth 9/32"	00
1-3/4"	Hexagon Plate	Overall: 2-3/4" x 2-3/4" Hole Spacing: Center dia. 65mm x 6 holes Attaching Bolt Size: M6 x 1.0P	02
1-3/4"	Square Plate	Overall: 2-7/8" x 2-7/8" Hole Spacing: 2-9/32" x 2-9/32" Attaching Bolt Size: M6 (1/4")	01
2-1/2"	Stemless	M12 x 1.75P Tap Depth 25/32"	00
1-3/4"	Square Plate	Overall: 3-35/64" x 3-35/64" Hole Spacing: 2-3/4" x 2-3/4" Attaching Bolt Size: M8 (5/16")	01

Code	Finish
IPC	Ivory Power Coating (Standard)
ZN	Zinc Plating
CR	Chrome Plating

LEVELING CASTERS

LEVELING CASTERS

Load Capacity Up to 2200 lbs.

- Stabilizer acts as a miniature "total lock" when fully engaged to prevent caster/equipment from moving.
- Excellent low profile caster.
- Double race swivel design.
- Stylish ivory powder coating.
- NSF Listed for food service industry.

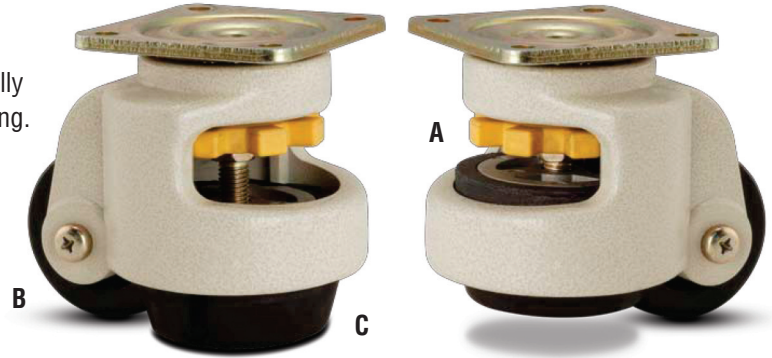

TYPICAL APPLICATIONS

- Computer Workstations.
- Printer and Other Electronic Equipment Stands.
- Work Tables.
- Food Service.
- Pharmaceutical.

- A.** Built-in leveler is easily adjustable.
- B.** Strong nylon wheel is non-marking.
- C.** Rubber stabilizer "post" helps absorb equipment shaking and shock (turn yellow dial until caster is lifted off the ground).

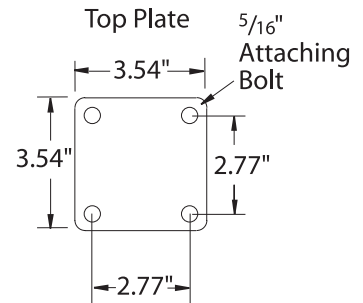
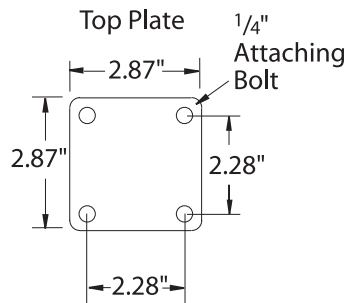
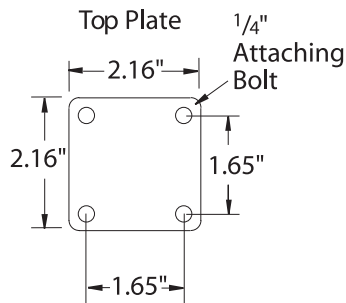

Dia. (inch)	Width (inch)	Hub (lbs.)	OAH (inch)	Max. OAH Using Leveler	Capacity (lb)	Swivel Lead (inch)	Weight (lb)	Part Number
1.68	.70	.80	2.80	3.27	110	3.40	.82	WSLCANNPL0104S
2.00	.88	.93	3.23	3.70	660	3.90	1.50	WSLCANNPL0204S
2.40	1.13	1.23	4.02	4.61	1320	5.30	3.00	WSLCANNPL02X4S
2.86	1.25	1.32	4.72	5.51	2200	5.60	3.70	WSLCANNPL0304S

NYLON WHEEL (NN) / RUBBER LEVELER PAD WITH PLAIN BEARING

LEVELING CASTERS STAINLESS STEEL

Stainless Steel Leveling Caster WMS-60S



FEATURES

- Smooth oscillating level operation.
- Premier type 304 stainless steel construction.
- Caster & leveler in one unit.

BENEFITS

- Excellent corrosion resistance.
- Non-marking pad and wheel.
- Hygienic design bearing cover.

IDEAL APPLICATIONS

- Food Processing Equipment.
- Pharmaceutical & Medical Equipment.
- Packaging Equipment.

PARTS	MATERIALS	FINISH, TYPE, COLOR
Top Plate	Stainless Steel	SUS304
Ball	Stainless Steel	SUS304
Frame	Stainless Steel	SUS304
Handle	Nylon - 6	Orange
Leveler	Stainless Steel	Natural
Pin	Stainless Steel	Natural
Pad	NBR Rubber	Black
Wheel	Nylon - 6	Black

* Ratchet handle: **Stainless Steel SUS304**

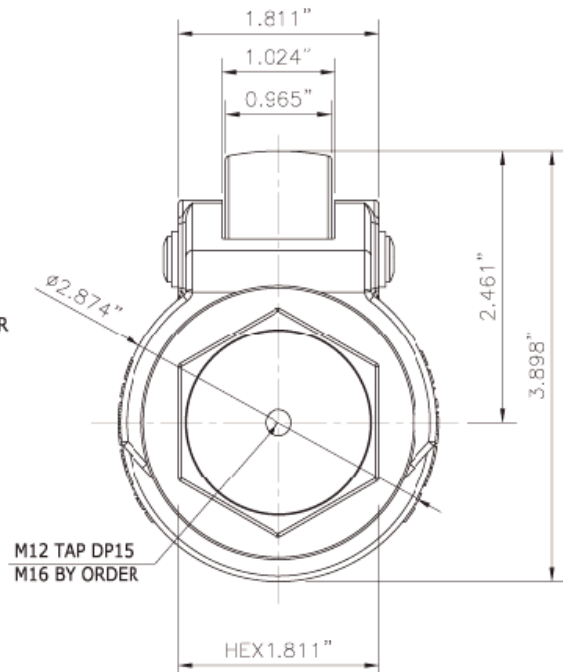
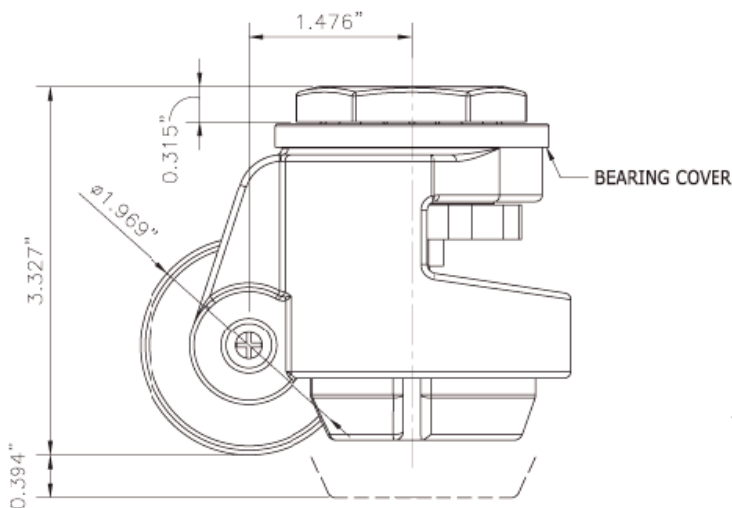

LEVELING CASTERS STAINLESS STEEL

PLATE MOUNTS THUMBWHEEL ADJUSTMENT STYLE

Part Number	Maximum Load	Recommended Load	Wheel Diameter	Wheel Width	Min. Height	Max. Height	Plate Size
WMS40F	220	110	1-3/4"	11/16"	2-13/16"	3-3/16"	2.16 x 2.16
WMS60F	1100	550	2"	1"	3-5/16"	3-11/16"	2.87 x 2.87
WMS80F	1763	882	2-1/2"	1-1/8"	4-1/8"	4-11/16"	3.54 x 3.54

PLATE MOUNTS RATCHET ADJUSTMENT STYLE

Part Number	Maximum Load	Recommended Load	Wheel Diameter	Wheel Width	Min. Height	Max. Height	Plate Size
WMISR60F	1100	550	2"	1"	3-5/16"	3-11/16"	2.87 x 2.87
WMISR-80F	1763	882	2-1/2"	1-1/8"	4-1/8"	4-11/16"	3.54 x 3.54

STEM MOUNTS THUMBWHEEL ADJUSTMENT STYLE

Part Number	Maximum Load	Recommended Load	Wheel Diameter	Wheel Width	Min. Height	Max. Height	Mounts Size
WMS40S	220	110	1-3/4"	11/16"	2-13/16"	3-3/16"	M8-1.25 TAP
WMS60S	1100	550	2"	1"	3-5/16"	3-11/16"	M12-1.75 TAP
WMS80S	1763	882	2-1/2"	1-1/8"	4-1/8"	4-11/16"	M12-1.75 TAP
WMSPIN40S	220	110	1-3/4"	11/16"	2-13/16"	3-3/16"	3/8"-16
WMSPIN60S	1100	550	2"	1"	3-5/16"	3-11/16"	1/2"-13
WMSPIN80S	1763	882	2-1/2"	1-1/8"	4-1/8"	4-11/16"	1/2"-13

DIECASTED LEVELING CASTERS

Diecasted Leveling Caster WGD-80F



IDEAL APPLICATIONS

- Semi-conductor Equipment.
- Assembly Equipment.
- Packaging Equipment.
- Workstations.
- Conveyor Systems.
- General Purpose.
- Food Processing Equipment.
- Pharmaceutical & Medical Equipment.

PARTS	MATERIALS	FINISH, TYPE, COLOR
Top Plate	SM45C	Zinc Galvanized
Ball	STB2	NI-Cr
Frame	ADC8	Ivory, Black, Gray
Handle	Nylon - 6	Orange
Leveler	SM45C	Zinc Galvanized
Pin	SM45C	Zinc Galvanized
Pad	NBR Rubber	Black
Wheel	Nylon - 6	Black

*120, 150 series: Handle - stainless steel nut

*120, 150 series: Leveler - stainless steel

*120, 150 series: Pad - ADC8

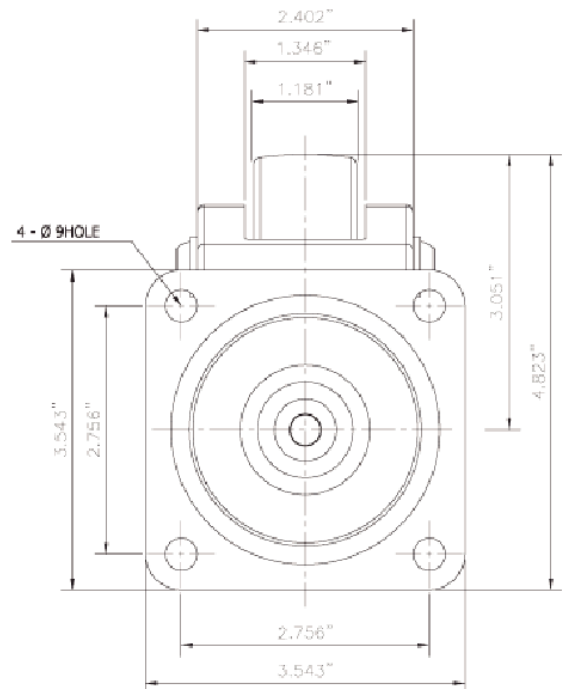
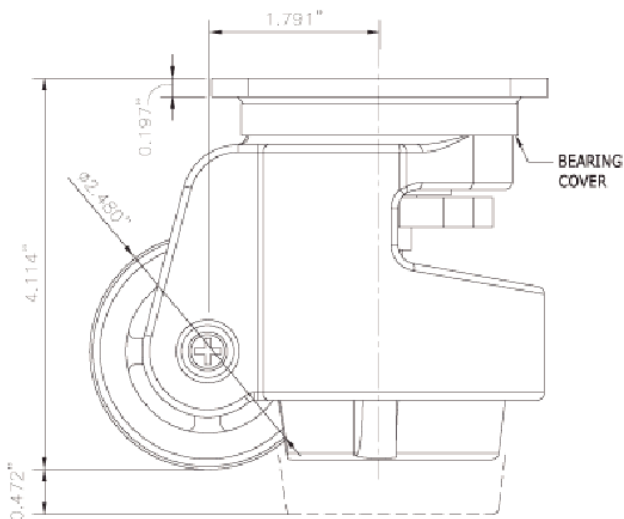

DIECASTED LEVELING CASTERS

PLATE MOUNTS THUMBWHEEL ADJUSTMENT STYLE

Part Number	Maximum Load	Recommended Load	Finish Color	Wheel Diameter	Wheel Width	Min. Height	Max. Height	Plate Size
WGD40F	110	60	Ivory	1-3/4"	11/16"	2-13/16"	3-3/16"	2.16" x 2.16"
WMI40F	110	60	Gray/Black	1-3/4"	11/16"	2-13/16"	3-3/16"	2.16" x 2.16"
WGD60F	550	300	Ivory	2"	1"	3-5/16"	3-11/16"	2.87" x 2.87"
WMI60F	550	300	Gray/Black	2"	1"	3-5/16"	3-11/16"	2.87" x 2.87"
WGD80F	1100	600	Ivory	2-1/2"	1-3/16"	4-1/8"	4-11/16"	3.54" x 3.54"
WMI80F	1100	600	Gray/Black	2-1/2"	1-3/16"	4-1/8"	4-11/16"	3.54" x 3.54"
WGD100F	1653	825	Ivory	2-13/16"	1-3/16"	4-3/4"	5-3/16"	3.74" x 3.74"
WMI100F	1653	825	Gray/Black	2-13/16"	1-3/16"	4-3/4"	5-3/16"	3.74" x 3.74"
WGD120F	2220	1100	Ivory	2-13/16"	1-3/16"	4-3/4"	5-3/16"	3.74" x 3.74"
WMI120F	2220	1100	Gray/Black	2-13/16"	1-3/16"	4-3/4"	5-3/16"	3.74" x 3.74"
WGD150F	3300	1650	Ivory	3-13/16"	2-7/32"	3-3/16"	5-3/4"	3.94" x 3.94"
WMI150F	3300	1650	Gray/Black	3-13/16"	2-7/32"	3-3/16"	5-3/4"	3.94" x 3.94"

PLATE MOUNTS RATCHET ADJUSTMENT STYLE

Part Number	Maximum Load	Recommended Load	Finish Color	Wheel Diameter	Wheel Width	Min. Height	Max. Height	Plate Size
WMIR60F	550	300	Ivory	2"	1"	3-5/16"	3-11/16"	2.87" x 2.87"
WMIR60F	550	300	Gray/Black	2"	1"	3-5/16"	3-11/16"	2.87" x 2.87"
WMIR80F	1100	600	Ivory	2-1/2"	1-3/16"	4-1/8"	4-11/16"	3.54" x 3.54"
WMIR80F	1100	600	Gray/Black	2-1/2"	1-3/16"	4-1/8"	4-11/16"	3.54" x 3.54"

STEM MOUNTS THUMBWHEEL ADJUSTMENT STYLE

Part Number	Maximum Load	Recommended Load	Finish Color	Wheel Diameter	Wheel Width	Min. Height	Max. Height	Plate Size
WGD40S	110	60	Ivory	1-3/4"	11/16"	2-13/16"	3-3/16"	M8-1.25 TAP
WMI40S	110	60	Gray/Black	1-3/4"	11/16"	2-13/16"	3-3/16"	M8-1.25 TAP
WMPIN40S	110	60	Ivory	1-3/4"	11/16"	2-13/16"	3-3/16"	3/8-16"
WMPIN40S	110	60	Gray/Black	1-3/4"	11/16"	2-13/16"	3-3/16"	3/8-16"
WGD60S	550	300	Ivory	2"	1"	3-5/16"	3-11/16"	M12-1.75 TAP
WMI60S	550	300	Gray/Black	2"	1"	3-5/16"	3-11/16"	M12-1.75 TAP
WMPIN60S	550	300	Ivory	2"	1"	3-5/16"	3-11/16"	1/2-13"
WMPIN60S	550	300	Gray/Black	2"	1"	3-5/16"	3-11/16"	1/2-13"
WGD80S	1100	600	Ivory	2-1/2"	1-3/16"	4-1/8"	4-11/16"	M12-1.75 TAP
WMI80S	1100	600	Gray/Black	2-1/2"	1-3/16"	4-1/8"	4-11/16"	M12-1.75 TAP
WMPIN80S	1100	600	Ivory	2-1/2"	1-3/16"	4-1/8"	4-11/16"	1/2-13"
WMPIN80S	1100	600	Gray/Black	2-1/2"	1-3/16"	4-1/8"	4-11/16"	1/2-13"
WGD100S	1653	825	Ivory	2-13/16"	1-3/16"	4-3/4"	5-3/16"	M16-2.0 TAP
WMI100S	1653	825	Gray/Black	2-13/16"	1-3/16"	4-3/4"	5-3/16"	M16-2.0 TAP
WMPIN100S	1653	825	Ivory	2-13/16"	1-3/16"	4-3/4"	5-3/16"	5/8-11"
WMPIN100S	1653	825	Gray/Black	2-13/16"	1-3/16"	4-3/4"	5-3/16"	5/8-11"
WGD120S	2200	1100	Ivory	2-13/16"	1-3/16"	4-3/4"	5-3/16"	M16-2.0 TAP
WMI120S	2200	1100	Gray/Black	2-13/16"	1-3/16"	4-3/4"	5-3/16"	M16-2.0 TAP
WMPIN120S	2200	1100	Ivory	2-13/16"	1-3/16"	4-3/4"	5-3/16"	5/8-11"
WMPIN120S	2200	1100	Gray/Black	2-13/16"	1-3/16"	4-3/4"	5-3/16"	5/8-11"

**Model part number corresponds to finish color: GRY - Gray, BLK - Black (i.e. WMI-60S-GRY)

** Model No.: GRY: Gray BLK: Black