

# GHKU TOTAL LOCK SERIES KINGPINLESS CASTERS

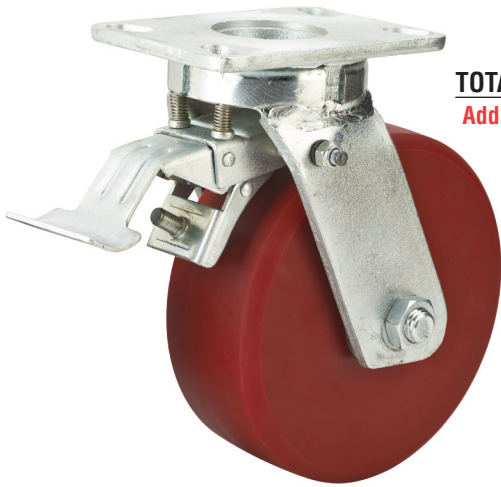

**LEADING SIDE  
TOTAL LOCK SWIVEL CASTER**  
Add TL to swivel caster number

Available Toe Guard TO

**NEW TRAILING SIDE  
TOTAL LOCK SWIVEL CASTER**  
No need to move cots back and forth  
for finding the brake pedal.  
Add TLT to swivel caster number  
Available in 6" & 8"

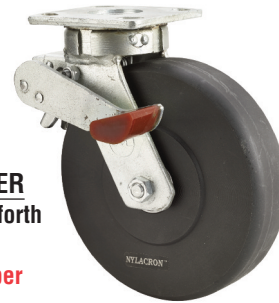

Swivel Head Section



Total Lock System

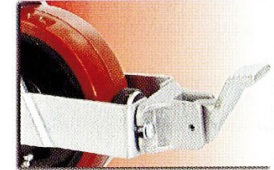

Wheel Face Break



Directional Lock

## 2,000 LBS. LOAD CAPACITY FORGED KINGPINLESS TYPE CASTERS

- Single piece Drop Forged AISI 1045 Steel Top Plate and Fork Base
- Precision CNC Machined Raceways with Kingpinless construction
- Induction Hardening of Raceways ensures uniform depth of hardness
- Totally Sealed Swivel Head with Grease Nipple
- 1/4" Thick Fork Legs robotically welded inside & outside to 2 1/2" fork spacing
- 1/2" Wheel axle
- 4 Position Foot Operated Directional Lock Slots
- Finish: Bright Zinc Plated

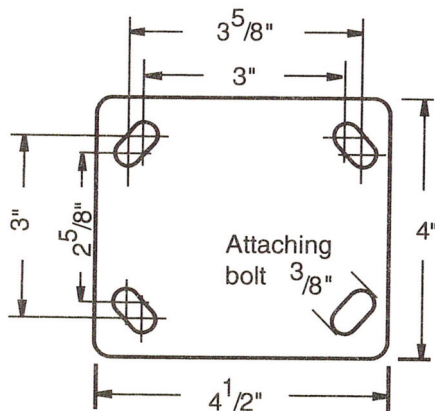

**TOP PLATE**  
4 X 4-1/2

**BOLT HOLE CENTER**  
2-5/8 X 3-5/8  
**SLOTTED TO**  
3 X 3

**ATTACHING BOLT SIZE**  
3/8

**RIG OPTIONS**  
**DL:** FOOT OPERATED  
4-WAY DIRECTIONAL LOCK

**WFB:** WHEEL FACE BRAKE  
ADD TO SUFFIX  
TO THE CASTER PART NUMBER

# 4

# GHKU TOTAL LOCK SERIES KINGPINLESS CASTERS

## SAS WHEELS

### HIGH CAPACITY POLYURETHANE TREAD WHEELS CAST IRON CORE

- Polyurethane firmly bonded to Precision Machined Cast Iron Core
- 93+ 3 Shore A
- Low rolling resistance, smooth and noiseless running

- Non-marking and floor protective
- High abrasion, cut and tear resistant
- Precision Ball Bearings
- Temperature Range: -40°F to +180°F
- **Available in Anti-Static add "AS" after wheel**



Part Number Swivel Caster	Part Number Swivel with Total Lock	Part Number Rigid Caster	Wheel Diameter (inch)	Tread Width (inch)	Load Capacity (lbs)	Overall Height (inch)	Swivel Radius (inch)	Swivel Radius w/Total Lock (inch)	Swivel Radius w/Wheel Brake (inch)
GHKU42SSAS	GHKU42SSASTL	GHKU42RSAS	4	2	900	5-5/8	3-3/16	4	8-1/2
GHKU52SSAS	GHKU52SSASTL	GHKU52RSAS	5	2	1200	6-1/2	3-7/8	4	9-1/2
GHKU62SSAS	GHKU62SSASTL	GHKU62RSAS	6	2	1650	7-1/2	4-9/16	6	10
GHKU82SSAS	GHKU82SSASTL	GHKU82RSAS	8	2	2000	9-1/2	6	6	11-1/2

## ME WHEELS

### ERGONOMIC POLYURETHANE DONUT TREAD WHEELS CAST IRON CORE

- For Low Push-Pull Efforts
- Polyurethane firmly bonded to Precision Machined Cast Iron Core
- Red Tread 93+ 3 Shore A
- Non-marking and floor protective

- Tread Options:  
Softer 80A - Yellow Tread (specify ME-Z)  
Harder 73D - Blue Tread (specify ME-F)
- Precision Ball Bearings
- Temperature Range: -40°F to +180°F
- **Available in Anti-Static add "AS" after wheel**



Part Number Swivel Caster	Part Number Swivel with Total Lock	Part Number Rigid Caster	Wheel Diameter (inch)	Tread Width (inch)	Load Capacity (lbs)	Overall Height (inch)	Swivel Radius (inch)	Swivel Radius w/Total Lock (inch)	Swivel Radius w/Wheel Brake (inch)
GHKU42SME	GHKU42SMETL	GHKU42RME	4	2	775	5-5/8	3-3/16	4	8-1/2
GHKU52SME	GHKU52SMETL	GHKU52RME	5	2	1000	6-1/2	3-7/8	4	9-1/2
GHKU62SME	GHKU62SMETL	GHKU62RME	6	2	1250	7-1/2	4-9/16	6	10
GHKU82SME	GHKU82SMETL	GHKU82RME	8	2	1700	9-1/2	6	6	11-1/2

## SZS WHEELS

### ELASTIC POLYURETHANE TREAD WHEELS CAST IRON CORE

- Polyurethane firmly bonded to Precision Machined Cast Iron Core
- 85+ 3 Shore A
- Excellent for power towing applications

- Reduced noise due to cushioning of loads, Lively Polyurethane allows wheels to "Flex and Roll" over debris
- Non-marking and floor protective
- Precision Ball Bearings
- Temperature Range: -40°F to +180°F
- **Available in Anti-Static add "AS" after wheel**



Part Number Swivel Caster	Part Number Swivel with Total Lock	Part Number Rigid Caster	Wheel Diameter (inch)	Tread Width (inch)	Load Capacity (lbs)	Overall Height (inch)	Swivel Radius (inch)	Swivel Radius w/Total Lock (inch)	Swivel Radius w/Wheel Brake (inch)
GHKU42SSZS	GHKU42SSZSTL	GHKU42RSZS	4	2	550	5-5/8	3-3/16	4	8-1/2
GHKU52SSZS	GHKU52SSZSTL	GHKU52RSZS	5	2	775	6-1/2	3-7/8	4	9-1/2
GHKU62SSZS	GHKU62SSZSTL	GHKU62RSZS	6	2	1000	7-1/2	4-9/16	6	10
GHKU82SSZS	GHKU82SSZSTL	GHKU82RSZS	8	2	1450	9-1/2	6	6	11-1/2

SEN  
WHEELS

## SOLID ELASTOMER WHEEL NYLON CORE

- 70 Shore (D) durometer
- FDA standards for use in food processing environments
- 100% washable

- Glass-filled nylon core insert endures heat
- High impact and abrasion resistant
- Resists oil, grease, water, and most solvents
- Temp Range: -50°F to +180°F



Part Number Swivel Caster	Part Number Swivel with Total Lock	Part Number Rigid Caster	Wheel Diameter (inch)	Tread Width (inch)	Load Capacity (lbs)	Overall Height (inch)	Swivel Radius (inch)	Swivel Radius w/Total Lock (inch)	Swivel Radius w/Wheel Brake (inch)
GHKU42SSEN	GHKU42SSENTL	GHKU42RSEN	4	2	1500	5-5/8	3-3/16	4	8-1/2
GHKU52SSEN	GHKU52SSENTL	GHKU52RSEN	5	2	1800	6-1/2	3-7/8	4	9-1/2
GHKU62SSEN	GHKU62SSENTL	GHKU62RSEN	6	2	2000	7-1/2	4-9/16	6	10
GHKU82SSEN	GHKU82SSENTL	GHKU82RSEN	8	2	2000	9-1/2	6	6	11-1/2

## SJS WHEELS

POLYURETHANE TREAD WHEELS  
CAST IRON CORE

- Polyurethane tread wheels firmly bonded to Precision Machined Cast Iron Core
- 93 + 3 Shore A
- Low rolling resistance; Smooth and noiseless running
- Non-marking and floor protective

- Good abrasion and cut resistance
- Ideal for medium duty applications
- Precision Ball Bearings
- Temperature Range: -40°F to +180°F
- **Available in Anti-Static add "AS" after wheel**

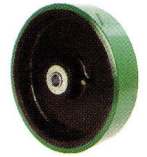

Part Number Swivel Caster	Part Number Swivel with Total Lock	Part Number Rigid Caster	Wheel Diameter (inch)	Tread Width (inch)	Load Capacity (lbs)	Overall Height (inch)	Swivel Radius (inch)	Swivel Radius w/Total Lock (inch)	Swivel Radius w/Wheel Brake (inch)
GHKU42SSJS	GHKU42SSJSTL	GHKU42RSJS	4	2	700	5-5/8	3-3/16	4	8-1/2
GHKU52SSJS	GHKU52SSJSTL	GHKU52RSJS	5	2	1000	6-1/2	3-7/8	4	9-1/2
GHKU62SSJS	GHKU62SSJSTL	GHKU62RSJS	6	2	1200	7-1/2	4-9/16	6	10
GHKU82SSJS	GHKU82SSJSTL	GHKU82RSJS	8	2	1500	9-1/2	6	6	11-1/2

## MDW WHEELS

## DUCTILE CAST STEEL WHEELS

- Machined tread face
- Crown tread face makes maneuverability easy
- Higher load capacities compared to cast iron wheels

- Suitable for extra heavy loads towed in punishing conditions
- High abrasion and oil resistance
- Precision Ball Bearings
- Temperature Range: 800°F

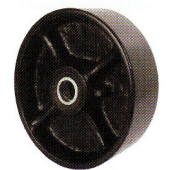

Part Number Swivel Caster	Part Number Swivel with Total Lock	Part Number Rigid Caster	Wheel Diameter (inch)	Tread Width (inch)	Load Capacity (lbs)	Overall Height (inch)	Swivel Radius (inch)	Swivel Radius w/Total Lock (inch)	Swivel Radius w/Wheel Brake (inch)
GHKU42SMDW	GHKU42SMDWTL	GHKU42RMDW	4	2	1500	5-5/8	3-3/16	4	8-1/2
GHKU52SMDW	GHKU52SMDWTL	GHKU52RMDW	5	2	1550	6-1/2	3-7/8	4	9-1/2
GHKU62SMDW	GHKU62SMDWTL	GHKU62RMDW	6	2	2000	7-1/2	4-9/16	6	10
GHKU82SMDW	GHKU82SMDWTL	GHKU82RMDW	8	2	2000	9-1/2	6	6	11-1/2

## DF WHEELS

## HOT FORGED STEEL WHEELS

- AISI 1045 steel with machined tread faces
- Virtually indestructible and easy to maneuver
- High abrasion and oil resistant

- Can be used in the roughest of applications on the poorest of floors
- Precision Ball Bearings
- Temperature Range: -150°F to +800°F



Part Number Swivel Caster	Part Number Swivel with Total Lock	Part Number Rigid Caster	Wheel Diameter (inch)	Tread Width (inch)	Load Capacity (lbs)	Overall Height (inch)	Swivel Radius (inch)	Swivel Radius w/Total Lock (inch)	Swivel Radius w/Wheel Brake (inch)
GHKU42SDF	GHKU42SDFTL	GHKU42RDF	4	2	1800	5-5/8	3-3/16	4	8-1/2
GHKU52SDF	GHKU52SDFTL	GHKU52RDF	5	2	2000	6-1/2	3-7/8	4	9-1/2
GHKU62SDF	GHKU62SDFTL	GHKU62RDF	6	2	2000	7-1/2	4-9/16	6	10
GHKU82SDF	GHKU82SDFTL	GHKU82RDF	8	2	2000	9-1/2	6	6	11-1/2

## NY/MD WHEELS

## NYLACRON™ WHEELS

- Precision Machined from Cast Polyamide. Hardness 112-120 Rockwell R
- Ultimate choice for extremely high load applications to replace metallic wheels
- Offer very high abrasion resistance and very low rolling resistance under extreme loads

- Resistant to salt, grease, alcohol and mild acids - can be used in corrosive applications with appropriate bearings
- Precision Ball Bearings
- Temperature Range: -40°F to +270°F

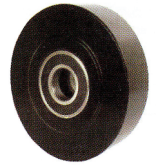

Part Number Swivel Caster	Part Number Swivel with Total Lock	Part Number Rigid Caster	Wheel Diameter (inch)	Tread Width (inch)	Load Capacity (lbs)	Overall Height (inch)	Swivel Radius (inch)	Swivel Radius w/Total Lock (inch)	Swivel Radius w/Wheel Brake (inch)
GHKU42SNYMD	GHKU42SNYMDTL	GHKU42RNYMD	4	2	2000	5-5/8	3-3/16	4	8-1/2
GHKU52SNYMD	GHKU52SNYMDTL	GHKU52RNYMD	5	2	2000	6-1/2	3-7/8	4	9-1/2
GHKU62SNYMD	GHKU62SNYMDTL	GHKU62RNYMD	6	2	2000	7-1/2	4-9/16	6	10
GHKU82SNYMD	GHKU82SNYMDTL	GHKU82RNYMD	8	2	2000	9-1/2	6	6	11-1/2

## NY/MC WHEELS

## NYLACRON™ WHITE WHEELS

- Precision Machined from cast polyamide hardness 112-120 Rockwell R
- Ultimate choice for extremely high load applications to replace metallic wheels
- Offer very high abrasion resistance and very low rolling resistance under extreme loads

- Resistant to salt, grease, alcohol and mild acids - can be used in corrosive applications with appropriate bearings
- Precision Ball Bearings
- Temperature Range: -40°F to +270°F



Part Number Swivel Caster	Part Number Swivel with Total Lock	Part Number Rigid Caster	Wheel Diameter (inch)	Tread Width (inch)	Load Capacity (lbs)	Overall Height (inch)	Swivel Radius (inch)	Swivel Radius w/Total Lock (inch)	Swivel Radius w/Wheel Brake (inch)
GHKU42SNYMC	GHKU42SNYMCTL	GHKU42RNYMC	4	2	2000	5-5/8	3-3/16	4	8-1/2
GHKU52SNYMC	GHKU52SNYMCTL	GHKU52RNYMC	5	2	2000	6-1/2	3-7/8	4	9-1/2
GHKU62SNYMC	GHKU62SNYMCTL	GHKU62RNYMC	6	2	2000	7-1/2	4-9/16	6	10
GHKU82SNYMC	GHKU82SNYMCTL	GHKU82RNYMC	8	2	2000	9-1/2	6	6	11-1/2

Swivel-EAZ™ Wheels available. Durometers: 70A (Black), 80A (Red), 95A (Blue), 60D (Gray), 75D (Black)

See wheel section for load ratings.

# 4

## GHKU KINGPINLESS STAINLESS STEEL TOTAL LOCK SERIES CASTERS

### SS WHEELS

#### STAINLESS STEEL WHEELS

- Type 304 Stainless Steel
- Non-magnetic & Non-sparking
- Excellent corrosion resistance
- Slightly crowned tread face with rounded corners
- Stainless Steel Precision Ball Bearings

- Temperature Range: 800°F

Custom Stainless Steel Wheels  
made to your specifications

V-Groove - VG

Flanged - FL



Part Number Swivel Caster	Part Number Swivel with Total Lock	Part Number Rigid Caster	Wheel Diameter (inch)	Tread Width (inch)	Load Capacity (lbs)	Overall Height (inch)	Swivel Radius (inch)	Swivel Radius w/Total Lock (inch)	Swivel Radius w/Wheel Brake (inch)
GHKUSS42SSS	GHKUSS42SSSTL	GHKUSS42RSS	4	2	1000	5-5/8	3-3/16	4	8-1/2
GHKUSS52SSS	GHKUSS52SSSTL	GHKUSS52RSS	5	2	1000	6-1/2	3-7/8	4	9-1/2
GHKUSS62SSS	GHKUSS62SSSTL	GHKUSS62RSS	6	2	1000	7-1/2	4-9/16	6	10
GHKUSS82SSS	GHKUSS82SSSTL	GHKUSS82RSS	8	2	1000	9-1/2	6	6	11-1/2

### SEN WHEELS

#### SOLID ELASTOMER WHEEL NYLON CORE

- 70 Shore (D) durometer
- FDA standards for use in food processing environments
- 100% Washable

- Stainless Steel Precision Ball Bearings
- Glass-filled nylon core insert endures heat
- High impact and abrasion resistant
- Resists oil, grease, water, and most solvents
- Temp Range: -50°F to +180°F



Part Number Swivel Caster	Part Number Swivel with Total Lock	Part Number Rigid Caster	Wheel Diameter (inch)	Tread Width (inch)	Load Capacity (lbs)	Overall Height (inch)	Swivel Radius (inch)	Swivel Radius w/Total Lock (inch)	Swivel Radius w/Wheel Brake (inch)
GHKUSS42SSEN	GHKUSS42SSENTL	GHKUSS42RSEN	4	2	1000	5-5/8	3-3/16	4	8-1/2
GHKUSS52SSEN	GHKUSS52SSENTL	GHKUSS52RSEN	5	2	1400	6-1/2	3-7/8	4	9-1/2
GHKUSS62SSEN	GHKUSS62SSENTL	GHKUSS62RSEN	6	2	1700	7-1/2	4-9/16	6	10
GHKUSS82SSEN	GHKUSS82SSENTL	GHKUSS82RSEN	8	2	2000	9-1/2	6	6	11-1/2

### KR WHEELS

#### SOLID POLYURETHANE KRYTONIC™ WHEELS

- Polyether Polyurethane has excellent carrying capacity.
- Crown shape affords an easy-rolling quiet operation
- Greater service life and resistance to chunking, cutting and abrasive wear

- 100% washable, steam cleanable, and resistant to most chemicals
- Non-marking tread
- Durometer: 58 Shore D (+/-5)
- Stainless Steel Precision Ball Bearings
- Temperature Range: + 250°F for up to a 1/2 hour.



Part Number Swivel Caster	Part Number Swivel with Total Lock	Part Number Rigid Caster	Wheel Diameter (inch)	Tread Width (inch)	Load Capacity (lbs)	Overall Height (inch)	Swivel Radius (inch)	Swivel Radius w/Total Lock (inch)	Swivel Radius w/Wheel Brake (inch)
GHKUSS42SKR	GHKUSS42SKRTL	GHKUSS42RKR	4	2	500	5-5/8	3-3/16	4	8-1/2
GHKUSS52SKR	GHKUSS52SKRTL	GHKUSS52RKR	5	2	600	6-1/2	3-7/8	4	9-1/2
GHKUSS62SKR	GHKUSS62SKRTL	GHKUSS62RKR	6	2	700	7-1/2	4-9/16	6	10
GHKUSS82SKR	GHKUSS82SKRTL	GHKUSS82RKR	8	2	800	9-1/2	6	6	11-1/2

# 4

## GHKU KINGPINLESS STAINLESS STEEL TOTAL LOCK SERIES CASTERS



**LEADING SIDE  
TOTAL LOCK STAINLESS STEEL SWIVEL CASTER**

Add TL to swivel caster number

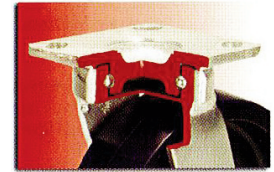

Swivel Head Section

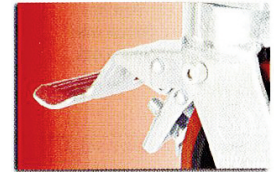

Total Lock System

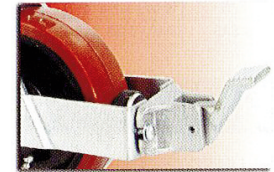

Wheel Face Break



Directional Lock

### 2,000 LBS. LOAD CAPACITY STAINLESS STEEL KINGPINLESS TYPE CASTERS

- Fabricated AISI 304 Stainless Steel Top Plate and Fork Base
- Precision CNC Machined Raceways with Kingpinless construction
- Totally Sealed Swivel Head with Grease Nipple
- 1/4" Thick Fork Legs Robotically welded Inside & Outside to 2 1/2" fork spacing
- 1/2" Wheel axle
- 4 Position Directional Lock Slots
- Finish: Bright Zinc Plated

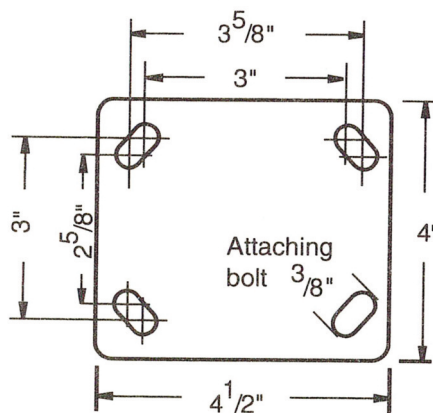

**TOP PLATE**  
4 X 4-1/2

**BOLT HOLE CENTER**  
2-5/8 X 3-5/8  
**SLOTTED TO**  
3 X 3

**ATTACHING BOLT SIZE**  
3/8

#### RIG OPTIONS

**DL: 4-WAY DIRECTIONAL LOCK**  
**WFB: WHEEL FACE BRAKE**  
ADD TO SUFFIX  
OF THE CASTER PART NUMBER

# 4

## GHKU KINGPINLESS STAINLESS STEEL TOTAL LOCK SERIES CASTERS

### NY/MD WHEELS

#### NYLACRON™ WHEELS

- Precision Machined from Cast Polyamide. Hardness 112-120 Rockwell R
- Ultimate choice for Extremely High Load applications to replace metallic wheels
- Offer very high abrasion resistance and very low rolling resistance under extreme loads

- Resistant to salt, grease, alcohol and mild acids - can be used in corrosive applications with appropriate bearings
- Stainless Steel Precision Ball Bearings
- Temperature Range: -40°F to +270°F

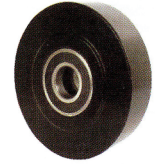

Part Number Swivel Caster	Part Number Swivel with Total Lock	Part Number Rigid Caster	Wheel Diameter (inch)	Tread Width (inch)	Load Capacity (lbs)	Overall Height (inch)	Swivel Radius (inch)	Swivel Radius w/Total Lock (inch)	Swivel Radius w/Wheel Brake (inch)
GHKUSS42SNYMD	GHKUSS42SNYMDTL	GHKUSS42RNYMD	4	2	2000	5-5/8	3-3/16	4	8-1/2
GHKUSS52SNYMD	GHKUSS52SNYMDTL	GHKUSS52RNYMD	5	2	2000	6-1/2	3-7/8	4	9-1/2
GHKUSS62SNYMD	GHKUSS62SNYMDTL	GHKUSS62RNYMD	6	2	2000	7-1/2	4-9/16	6	10
GHKUSS82SNYMD	GHKUSS82SNYMDTL	GHKUSS82RNYMD	8	2	2000	9-1/2	6	6	11-1/2

### NY/MC WHEELS

#### NYLACRON™ WHITE WHEELS

- Precision Machined from Cast Polyamide. Hardness 112-120 Rockwell R
- Ultimate choice for Extremely High Load applications to replace metallic wheels
- Offer very high abrasion resistance and very low rolling resistance under extreme loads

- Resistant to salt, grease, alcohol and mild acids - can be used in corrosive applications with appropriate bearings
- Stainless Steel Precision Ball Bearings
- Temperature Range: -40°F to +270°F



Part Number Swivel Caster	Part Number Swivel with Total Lock	Part Number Rigid Caster	Wheel Diameter (inch)	Tread Width (inch)	Load Capacity (lbs)	Overall Height (inch)	Swivel Radius (inch)	Swivel Radius w/Total Lock (inch)	Swivel Radius w/Wheel Brake (inch)
GHKUSS42SNYMC	GHKUSS42SNYMC TL	GHKUSS42RNYMC	4	2	2000	5-5/8	3-3/16	4	8-1/2
GHKUSS52SNYMC	GHKUSS52SNYMC TL	GHKUSS52RNYMC	5	2	2000	6-1/2	3-7/8	4	9-1/2
GHKUSS62SNYMC	GHKUSS62SNYMC TL	GHKUSS62RNYMC	6	2	2000	7-1/2	4-9/16	6	10
GHKUSS82SNYMC	GHKUSS82SNYMC TL	GHKUSS82RNYMC	8	2	2000	9-1/2	6	6	11-1/2

### NN WHEELS

#### NYLON WHEELS

- Injection molded from Nylon 6
- 100% washable & steam cleanable; impervious to water, highly resistant to organic solvents, most chemicals & cleaning solutions; ideal for use in food processing and packaging plants
- Offer high impact strength and exceptional abrasion resistance

- Hard tread has slight crown and rolls very easily
- Non-marking
- Durometer: 75 Shore D (+/-5)
- Stainless Steel Precision Ball Bearings
- Temperature Range: -40°F to +180°F
- Available in Anti-Static add "AS"



Part Number Swivel Caster	Part Number Swivel with Total Lock	Part Number Rigid Caster	Wheel Diameter (inch)	Tread Width (inch)	Load Capacity (lbs)	Overall Height (inch)	Swivel Radius (inch)	Swivel Radius w/Total Lock (inch)	Swivel Radius w/Wheel Brake (inch)
GHKUSS42SNN	GHKUSS42SNN TL	GHKUSS42RNN	4	2	1320	5-5/8	3-3/16	4	8-1/2
GHKUSS52SNN	GHKUSS52SNN TL	GHKUSS52RNN	5	2	1320	6-1/2	3-7/8	4	9-1/2
GHKUSS62SNN	GHKUSS62SNN TL	GHKUSS62RNN	6	2	1320	7-1/2	4-9/16	6	10
GHKUSS82SNN	GHKUSS82SNN TL	GHKUSS82RNN	8	2	2000	9-1/2	6	6	11-1/2