

46 SERIES HYBRID HEAVY DUTY KINGPIN CASTERS

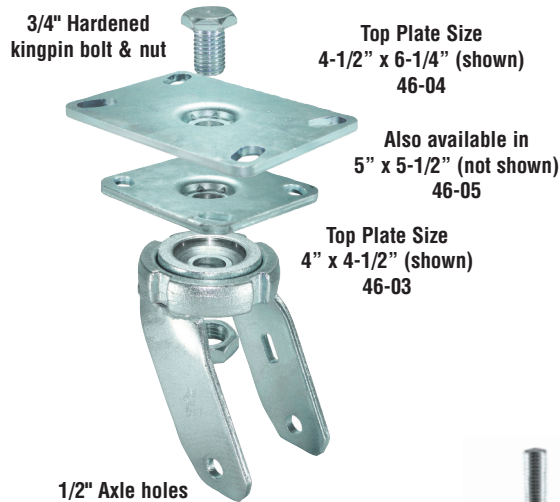

3/4" Hardened kingpin bolt & nut

Top Plate Size
4-1/2" x 6-1/4" (shown)
46-04

Also available in
5" x 5-1/2" (not shown)
46-05

Top Plate Size
4" x 4-1/2" (shown)
46-03

1/2" Axle holes

ADD TOP PLATE SIZE TO END OF CASTER*
03, 04, 05

- Hot forged ASTM 1045 steel legs and yoke base
- Heavy duty induction hardened sealed raceway
- 3/8" diameter HRC45 steel ball bearing raceway
- Heat treated 3/4" diameter kingpin & nut
- Double welded legs
- Endless fastening capabilities



HYBRID STEM CASTER*
3/4" HOLE SIZE

ADD STEM SIZE TO END OF CASTER



TOP LOCK
TS



CAM LOCK
MS



4 POSITION LOCK
PS

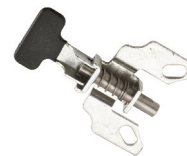

FOOT OPERATED SWIVEL LOCK
only available in
4" x 4-1/2" top plate

2,000 LBS. LOAD CAPACITY FORGED HYBRID KINGPIN CASTERS

- Kingpinless strength with Kingpin simplicity
- Kingpinless style drop forged swivel raceway
3/8" Ball bearings (HRC45 steel)
- 3/4" Kingpin/Nut hardened
- 1/4" Cold forged top plate (ASTM 1045)
- 1/2" Axle holes
- Long life of caster with low cost
- Extra high endurance in distance traveled
- Hub length 2 1/2"

ALL WHEELS AVAILABLE WITH PRECISION BEARINGS (63) OR ROLLER BEARINGS (38)

Caster Options: 304 Stainless Steel - "S" prefix

Other Options: Zerk axle - "Z" suffix

Plate size: 4" x 4 1/2"

Bolt Diameter: 3/8"

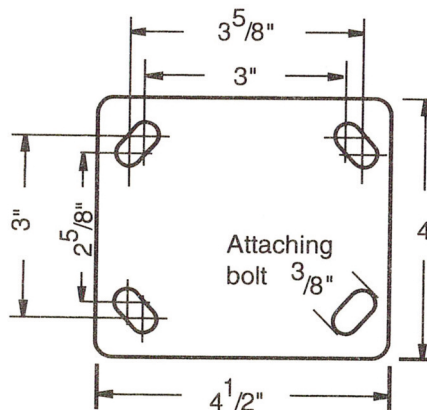

STANDARD
46 03 TOP PLATE
4 X 4-1/2

BOLT HOLE CENTER
2-5/8 X 3-5/8
SLOTTED TO
3 X 3

ATTACHING BOLT SIZE
3/8

4

46 SERIES HYBRID HEAVY DUTY KINGPIN CASTERS

MU
WHEELS

POLYURETHANE ON GLASS-FILLED NYLON

- 10mm blue tread
- 90-95 Durometer Shore (A) (Green Thread)
- 60-70 Durometer Shore (D)
- Light weight reinforced glass-filled nylon core

- Non-marking, non-staining, non-conductive tread
- Floor protective
- Resists oil, grease, water, and most solvents
- Temp Range: -45°F to +180°F



Part Number Swivel Caster	Part Number Rigid Caster	Wheel Diameter (inch)	Tread Width (inch)	Load Capacity (lbs)	Overall Height (inch)	Swivel Radius (inch)	Precision Bearing
46CS420MU63	46CR420MU63	4	2	800	5-5/8	3-1/8	63
46CS520MU63	46CR520MU63	5	2	1400	6-1/2	3-3/4	63
46CS620MU63	46CR620MU63	6	2	1400	7-1/2	4-1/2	63
46CS820MU63	46CR820MU63	8	2	1800	9-1/2	6-5/16	63

PTU
WHEELS

POLYURETHANE ON POLYOLEFIN

- 90-95 Durometer Shore (A) Ductile Polyurethane tread mechanically bonded to Polyolefin core
- High capacity and lightweight
- Resists oil, grease, water, and most solvents

- Smooth rolling and quiet
- Temp Range: -45°F to +180°F
- Options: Flat Tread & Donut Tread**
- Donut Tread PTU (6", 8") DTU



Part Number Swivel Caster	Part Number Rigid Caster	Wheel Diameter (inch)	Tread Width (inch)	Load Capacity (lbs)	Overall Height (inch)	Swivel Radius (inch)	Precision Bearing
46CS420PTU38	46CR420PTU38	4	2	700	5-5/8	3-1/8	38
46CS520PTU38	46CR520PTU38	5	2	1000	6-1/2	3-3/4	38
46CS620PTU38	46CR620PTU38	6	2	1200	7-1/2	4-1/2	38
46CS820PTU38	46CR820PTU38	8	2	1400	9-1/2	6-5/16	38

SEN
WHEELS

SOLID ELASTOMER WHEEL NYLON CORE

- 70 Shore (D) durometer
- FDA standards for use in food processing environments
- 100% Washable

- Glass-filled nylon core insert endures heat
- High impact and abrasion resistant
- Resists oil, grease, water, and most solvents
- Temp Range: -50°F to +180°F



Part Number Swivel Caster	Part Number Rigid Caster	Wheel Diameter (inch)	Tread Width (inch)	Load Capacity (lbs)	Overall Height (inch)	Swivel Radius (inch)	Precision Bearing
46CS420SEN63	46CR420SEN63	4	2	1500	5-5/8	3-1/8	63
46CS520SEN63	46CR520SEN63	5	2	1800	6-1/2	3-3/4	63
46CS620SEN63	46CR620SEN63	6	2	2100	7-1/2	4-1/2	63
46CS820SEN63	46CR820SEN63	8	2	2600	9-1/2	6-5/16	63

DS
WHEELS

DUCTILE STEEL

- Extreme heavy duty applications
- High capacity

- Effortless rolling under heavy loads
- Temp Range: -45°F to +800°F

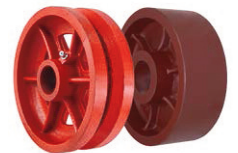

Part Number Swivel Caster	Part Number Rigid Caster	Wheel Diameter (inch)	Tread Width (inch)	Load Capacity (lbs)	Overall Height (inch)	Swivel Radius (inch)	Precision Bearing
46CS420DS38	46CR420DS38	4	2	1200	5-5/8	3-1/8	38
46CS520DS38	46CR520DS38	5	2	1500	6-1/2	3-3/4	38
40CS620DS38	46CR620DS38	6	2	2000	7-1/2	4-1/2	38
40CS820DS38	46CR820DS38	8	2	2500	9-1/2	6-5/16	38

SPU
WHEELS

SOLID POLYURETHANE

- 60 Durometer Shore (D)
- FDA requirements met for use in food processing environments
- 100% Washable

- One piece mold design eliminates bonding failure
- High impact and abrasion resistant
- Resists oil, grease, water, and most solvents
- Temp Range: -45°F to +180°F



Part Number Swivel Caster	Part Number Rigid Caster	Wheel Diameter (inch)	Tread Width (inch)	Load Capacity (lbs)	Overall Height (inch)	Swivel Radius (inch)	Precision Bearing
46CS420SPU63	46CR420SPU63	4	2	700	5-5/8	3-1/8	63
46CS520SPU63	46CR520SPU63	5	2	1200	6-1/2	3-3/4	63
46CS620SPU63	46CR620SPU63	6	2	1200	7-1/2	4-1/2	63
46CS820SPU63	46CR820SPU63	8	2	1400	9-1/2	6-5/16	63

ERN
WHEELS

ELASTIC RUBBER ON NYLON

- 70-75 Durometer Shore (A)
- Elastic rubber molded to nylon core

- Non-marking
- Easy rolling, impact resistant and shock absorbing
- Temp Range: -40°F to +160°F



Part Number Swivel Caster	Part Number Rigid Caster	Wheel Diameter (inch)	Tread Width (inch)	Load Capacity (lbs)	Overall Height (inch)	Swivel Radius (inch)	Precision Bearing
46CS420ERN38	46CR420ERN38	4	2	325	5-5/8	3-1/8	38
46CS520ERN38	46CR520ERN38	5	2	475	6-1/2	3-3/4	38
46CS620ERN38	46CR620ERN38	6	2	500	7-1/2	4-1/2	38
46CS820ERN38	46CR820ERN38	8	2	600	9-1/2	6-5/16	38

NY/MD
WHEELS

NYLACRON™ WHEELS

- Precision Machined from Cast Polyamide. Hardness 112-120 Rockwell R
- Ultimate choice for Extremely High Load applications to replace metallic wheels
- Offer very high abrasion resistance and very low rolling resistance under extreme loads

- Resistant to salt, grease, alcohol and mild acids - can be used in corrosive applications with appropriate bearings
- Precision Ball Bearings
- Temperature Range: -40°F to +270°F

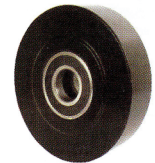

Part Number Swivel Caster	Part Number Rigid Caster	Wheel Diameter (inch)	Tread Width (inch)	Load Capacity (lbs)	Overall Height (inch)	Swivel Radius (inch)	Precision Bearing
46CS420NYMD	46CR420NYMD	4	2	2000	5-5/8	3-3/16	38
46CS520NYMD	46CR520NYMD	5	2	2000	6-1/2	3-7/8	38
46CS620NYMD	46CR620NYMD	6	2	2000	7-1/2	4-9/16	38
46CS820NYMD	46CR820NYMD	8	2	2000	9-1/2	6	38

**TUA
WHEELS****POLYURETHANE ON ALUMINUM FLAT TREAD**

- High Tech grade polyurethane tread
- 85 Durometer Shore (A) deflects debris

- Non-marking and rolls effortlessly
- Multi-year tread durability
- Temp Range: -40°F to +180°F

Part Number Swivel Caster	Part Number Rigid Caster	Wheel Diameter (inch)	Tread Width (inch)	Load Capacity (lbs)	Overall Height (inch)	Swivel Radius (inch)	Precision Bearing
46CS620TUA63	46CR620TUA63	6	2	1500	7-1/2	4-1/2	63
46CS820TUA63	46CR820TUA63	8	2	2000	9-1/2	6-5/16	63
46CS820TUA64	46CR820TUA64	8	2	2000	9-1/2	6-5/16	64

**DUA
WHEELS****POLYURETHANE ON ALUMINUM DONUT TREAD**

- High Tech grade polyurethane tread
- 85 Durometer Shore (A) deflects debris

- Non-marking and rolls effortlessly
- Multi-year tread durability
- Temp Range: -40°F to +180°F

Part Number Swivel Caster	Part Number Rigid Caster	Wheel Diameter (inch)	Tread Width (inch)	Load Capacity (lbs)	Overall Height (inch)	Swivel Radius (inch)	Precision Bearing
46CS420DUA63	46CR420DUA63	4	2	1000	5-5/8	3-1/8	63
46CS520DUA63	46CR520DUA63	5	2	1200	6-1/2	3-3/4	63
46CS620DUA63	46CR620DUA63	6	2	1500	7-1/2	4-1/2	63
46CS820DUA63	46CR820DUA63	8	2	2000	9-1/2	6-5/16	63

**NG
WHEELS****NYLON GLASS-FILLED**

- 85 Durometer Shore (A)
- Impervious to most chemicals, solvents, oil, salt, alkalines and water

- Use metal only bearing components for temperatures over 180°F
- Hi Temp: +490°F continuous, +550°F intermittent (part # TMA)

Part Number Swivel Caster	Part Number Rigid Caster	Wheel Diameter (inch)	Tread Width (inch)	Load Capacity (lbs)	Overall Height (inch)	Swivel Radius (inch)	Precision Bearing
46CS420NG38	46CR420NG38	4	2	800	5-5/8	3-1/8	38
46CS520NG38	46CR520NG38	5	2	1000	6-1/2	3-3/4	38
46CS620NG38	46CR620NG38	6	2	1200	7-1/2	4-1/2	38
46CS820NG38	46CR820NG38	8	2	1400	9-1/2	6-5/16	38

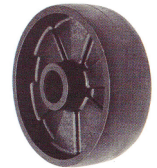
**PPU
WHEELS****POLYURETHANE ON POLYOLEFIN**

- Injection Molding Polyurethane Tread mechanically bonded to polyolefin core
- 90-95 Durometer Shore (A) Polyurethane Tread mechanically bonded to polyolefin core
- High capacity and lightweight

- Resist oil, grease, water and most solvents
- Smooth rolling and quiet
- Non-marking
- Temp Range: -45°F to +180°F

Part Number Swivel Caster	Part Number Rigid Caster	Wheel Diameter (inch)	Tread Width (inch)	Load Capacity (lbs)	Overall Height (inch)	Swivel Radius (inch)	Precision Bearing
46CS420PPU38	46CR420PPU38	4	2	700	5-5/8	3-1/8	38
46CS520PPU38	46CR520PPU38	5	2	750	6-1/2	3-3/4	38
46CS620PPU38	46CR620PPU38	6	2	900	7-1/2	4-1/2	38
46CS820PPU38	46CR820PPU38	8	2	1000	9-1/2	6-5/16	38

