

Caster Type**Page**

| | |
|---|-------|
| GAD Kingpinless Casters..... | 2-4 |
| 410 Kingpinless Casters..... | 5-7 |
| 415 Dual Wheel Kingpinless Casters..... | 8-9 |
| S410 Springloaded Casters..... | 10-11 |

ALL WHEELS ARE AVAILABLE WITH
PRECISION BALL BEARING, CENTERPIECE & END CAPS
FOR MANUAL OR TOWING TO FIT IN 3-1/2" HUB LENGTH RIGS.
See Wheel Section for complete selection.

7 GAD TOTAL LOCK KINGPINLESS SERIES CASTERS

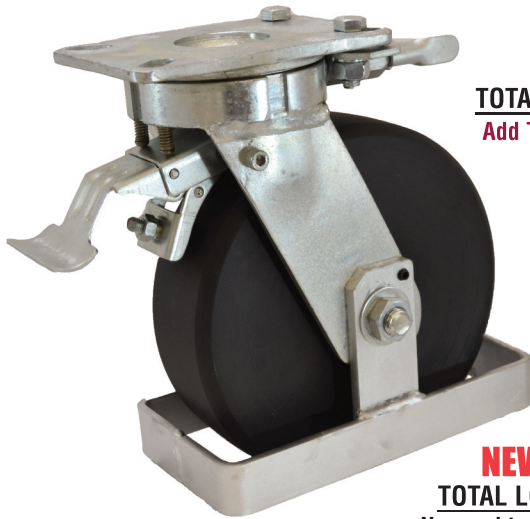

**LEADING SIDE
TOTAL LOCK SWIVEL CASTER**
Add TL to swivel caster number

Available Toe Guard
TO

**NEW TRAILING SIDE
TOTAL LOCK SWIVEL CASTER**
No need to move cots back and forth
for finding the brake pedal.
Add TLN to swivel caster number

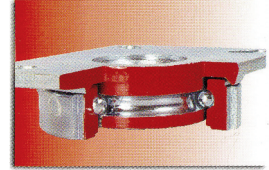

Swivel Head Section

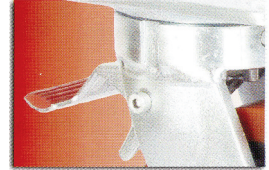

Total Lock System

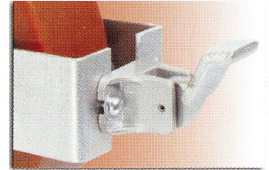

Wheel Face Brake

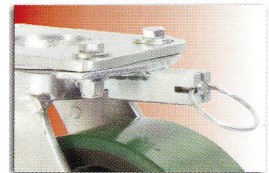

Directional Lock

5,000 LBS. LOAD CAPACITY FORGED KINGPINLESS TYPE CASTERS

- Single piece Drop Forged AISI 1045 Steel Top Plate and Fork Base.
- Precision CNC Machined Raceways with 3-1/2" diameter with 1/2" ball bearings.
- Induction Hardening of Raceways ensures uniform depth of hardness.
- Totally Sealed Swivel Head with Grease Nipple.
- 3/8" Thick x 3" wide Fork Legs Robotically welded Inside & Outside to 3 1/2" fork spacing.
- 3/4" Wheel axle.
- 4 Position Directional Lock Slots.
- Finish: Bright Zinc Plated.

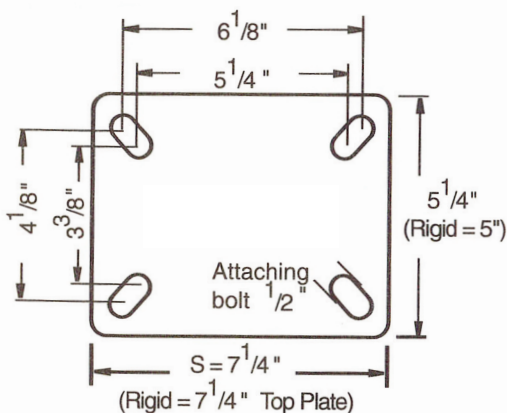

TOP PLATE
5-1/4 X 7-1/4

BOLT HOLE CENTER
3-3/8 X 5-1/4
SLOTTED TO
4-1/8 X 6-1/8

ATTACHING BOLT SIZE
1/2

RIG OPTIONS
DL: 4-WAY DIRECTIONAL LOCK

WFB: WHEEL FACE BRAKE
ADD TO SUFFIX
OF THE CASTER PART NUMBER

TOE GUARDS
SPECIFY "TO"
WITH CASTER NUMBER

7 GAD TOTAL LOCK KINGPINLESS SERIES CASTERS

NY/MD WHEELS

NYLACRON™ WHEELS

- Precision Machined from Cast Polyamide Hardness 112-120 Rockwell R.
- Ultimate choice for Extremely High Load applications to replace metallic wheels.
- Offer very high abrasion resistance and very low rolling resistance under extreme loads.

- Resistant to salt, grease, alcohol and mild acids - can be used in corrosive applications with appropriate bearings.
- Precision Ball Bearings.
- Temperature Range: -40°F to +270°F.

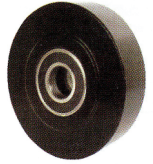

| Part Number Swivel Caster | Part Number Swivel with Total Lock | Part Number Rigid Caster | Wheel Diameter (inch) | Tread Width (inch) | Load Capacity (lbs) | Overall Height (inch) | Swivel Radius (inch) | Swivel Radius w/Total Lock (inch) | Swivel Radius w/Wheel Brake (inch) |
|---------------------------|------------------------------------|--------------------------|-----------------------|--------------------|---------------------|-----------------------|----------------------|-----------------------------------|------------------------------------|
| GADS63NYMD | GADTL63NYMD | GADR63NYMD | 6 | 3 | 5000 | 8 | 5-1/8 | 6 | 10-1/8 |
| GADS83NYMD | GADTL83NYMD | GADR83NYMD | 8 | 3 | 5000 | 10-1/2 | 6-1/2 | 6-1/4 | 11-1/4 |
| GADS103NYMD | GADTL103NYMD | GADR103NYMD | 10 | 3 | 5000 | 12-1/2 | 7-3/4 | 7-3/4 | 12-3/4 |
| GADS123NYMD | GADTL123NYMD | GADR123NYMD | 12 | 3 | 5000 | 15-1/2 | 8-3/8 | 8-3/8 | 13-3/8 |

NY/MC WHEELS

NYLACRON™ WHITE WHEELS

- Precision Machined from Cast Polyamide Hardness 112-120 Rockwell R.
- Ultimate choice for Extremely High Load applications to replace metallic wheels.
- Offer very high abrasion resistance and very low rolling resistance under extreme loads.

- Resistant to salt, grease, alcohol and mild acids - can be used in corrosive applications with appropriate bearings.
- Precision Ball Bearings.
- Temperature Range: -40°F to +270°F.



| Part Number Swivel Caster | Part Number Swivel with Total Lock | Part Number Rigid Caster | Wheel Diameter (inch) | Tread Width (inch) | Load Capacity (lbs) | Overall Height (inch) | Swivel Radius (inch) | Swivel Radius w/Total Lock (inch) | Swivel Radius w/Wheel Brake (inch) |
|---------------------------|------------------------------------|--------------------------|-----------------------|--------------------|---------------------|-----------------------|----------------------|-----------------------------------|------------------------------------|
| GADS63NYMC | GADTL63NYMC | GADR63NYMC | 6 | 3 | 5000 | 8 | 5-1/8 | 6 | 10-1/8 |
| GADS83NYMC | GADTL83NYMC | GADR83NYMC | 8 | 3 | 5000 | 10-1/2 | 6-1/2 | 6-1/4 | 11-1/4 |
| GADS103NYMC | GADTL103NYMC | GADR103NYMC | 10 | 3 | 5000 | 12-1/2 | 7-3/4 | 7-3/4 | 12-3/4 |
| GADS123NYMC | GADTL123NYMC | GADR123NYMC | 12 | 3 | 5000 | 15-1/2 | 8-3/8 | 8-3/8 | 13-3/8 |

MEGALOAD™ AND VULKOLLAN™ WHEELS WITH PRECISION BALL BEARINGS AVAILABLE TO FIT THIS CASTER SERIES.
SIZES 6 X 3, 8 X 3, 10 X 3 & 12 X 3.

SAS WHEELS

HIGH CAPACITY POLYURETHANE TREAD WHEELS CAST IRON CORE

- Polyurethane firmly bonded to Precision Machined Cast Iron Core
- 93+ 3 Shore A
- Low rolling resistance, smooth and noiseless running

- Non-marking and floor protective
- High abrasion, cut and tear resistant
- Precision Ball Bearings
- Temperature Range: -40°F to +180°F
- Available in Anti-Static add "AS" after wheel



| Part Number Swivel Caster | Part Number Swivel with Total Lock | Part Number Rigid Caster | Wheel Diameter (inch) | Tread Width (inch) | Load Capacity (lbs) | Overall Height (inch) | Swivel Radius (inch) | Swivel Radius w/Total Lock (inch) | Swivel Radius w/Wheel Brake (inch) |
|---------------------------|------------------------------------|--------------------------|-----------------------|--------------------|---------------------|-----------------------|----------------------|-----------------------------------|------------------------------------|
| GAD62SSAS | GAD62SSASTL | GAD62RSAS | 6 | 3 | 2300 | 8 | 5-1/8 | 6 | 10-1/8 |
| GAD82SSAS | GAD82SSASTL | GAD82RSAS | 8 | 3 | 3100 | 10-1/2 | 6-1/4 | 6-1/4 | 11-1/4 |
| GAD102SSAS | GAD102SSASTL | GAD102RSAS | 10 | 3 | 4000 | 12-1/2 | 7-3/4 | 7-3/4 | 12-3/4 |
| GAD122SSAS | GAD122SSASTL | GAD122RSAS | 12 | 3 | 4850 | 15-1/2 | 8-3-8 | 8-3-8 | 13-3/8 |

SJS WHEELS

POLYURETHANE WHEELS

- Polyurethane tread wheels firmly bonded to Precision Machined Cast Iron Core.
- 93 + 3 Shore A.
- Low rolling resistance; Smooth and noiseless running.
- Non-marking and floor protective.

- Good Abrasion and cut resistance.
- Ideal for medium duty applications.
- Precision Ball Bearings.
- Temperature Range: -40°F to +180°F.
- Available in Anti-Static add "AS" after wheel.

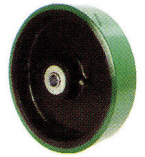

| Part Number Swivel Caster | Part Number Swivel with Total Lock | Part Number Rigid Caster | Wheel Diameter (inch) | Tread Width (inch) | Load Capacity (lbs) | Overall Height (inch) | Swivel Radius (inch) | Swivel Radius w/Total Lock (inch) | Swivel Radius w/Wheel Brake (inch) |
|---------------------------|------------------------------------|--------------------------|-----------------------|--------------------|---------------------|-----------------------|----------------------|-----------------------------------|------------------------------------|
| GAD62SSJS | GAD62SSJSTL | GAD62RSJS | 6 | 3 | 2100 | 8 | 5-1/8 | 6 | 10-1/8 |
| GAD82SSJS | GAD82SSJSTL | GAD82RSJS | 8 | 3 | 2500 | 10-1/2 | 6-1/4 | 6-1/4 | 11-1/4 |
| GAD102SSJS | GAD102SSJSTL | GAD102RSJS | 10 | 3 | 3000 | 12-1/2 | 7-3/4 | 7-3/4 | 12-3/4 |
| GAD122SSJS | GAD122SSJSTL | GAD122RSJS | 12 | 3 | 3500 | 15-1/2 | 8-3-8 | 8-3-8 | 13-3/8 |

ME WHEELS

ERGONOMIC POLYURETHANE DONUT TREAD WHEELS CAST IRON CORE

- For Low Push-Pull Efforts.
- Polyurethane firmly bonded to Precision Machined Cast Iron Core.
- Red Tread 93+ 3 Shore A.
- Non-marking and floor protective.

- Tread Options:
Softer 80A - Yellow Tread (specify ME-Z)
Harder 73D - Blue Tread (specify ME-F).
- Precision Ball Bearings.
- Temperature Range: -40°F to +180°F.
- Available in Anti-Static add "AS" after wheel.



| Part Number Swivel Caster | Part Number Swivel with Total Lock | Part Number Rigid Caster | Wheel Diameter (inch) | Tread Width (inch) | Load Capacity (lbs) | Overall Height (inch) | Swivel Radius (inch) | Swivel Radius w/Total Lock (inch) | Swivel Radius w/Wheel Brake (inch) |
|---------------------------|------------------------------------|--------------------------|-----------------------|--------------------|---------------------|-----------------------|----------------------|-----------------------------------|------------------------------------|
| GAD62SME | GAD62SMETL | GAD62RME | 6 | 3 | 1850 | 8 | 5-1/8 | 6 | 10-1/8 |
| GAD82SME | GAD82SMETL | GAD82RMES | 8 | 3 | 2400 | 10-1/2 | 6-1/4 | 6-1/4 | 11-1/4 |
| GAD102SME | GAD102SMETL | GAD102RME | 10 | 3 | 2850 | 12-1/2 | 7-3/4 | 7-3/4 | 12-3/4 |
| GAD122SME | GAD122SMETL | GAD122RME | 12 | 3 | 3500 | 15-1/2 | 8-3-8 | 8-3-8 | 13-3/8 |

7 410 KINGPINLESS CASTERS

4,100 LBS. LOAD CAPACITY KINGPINLESS TYPE CASTERS

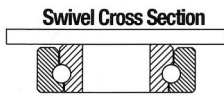

- **Top Plate:** 3/8" AISI 1045 heat treated steel welded inside and out for longer life.
- **Swivel Section:** One row of 1/2" ball bearings mounted in a heat treated precision machined raceway. Zerk in swivel section.
- **Yoke Base:** Notched AISI 1045 steel.
- **Legs:** 3/8" thick welded inside and out.
- **Axle:** 3/4" diameter.
- **Finish:** RoHS Zinc plating, for greater corrosion resistance than paint.



**TOE GUARDS
AVAILABLE WITH
ALL CASTERS.**

MOUNTING PLATE OPTIONS

TOP PLATE: (STANDARD)

- Plate Size:** 4-1/2" x 6-1/4"
- Bolt Holes:** 2-7/16" x 4-15/16"
slotted to
3-3/8" x 5-1/4"
- Bolt Size:** 1/2"

Nylacron™ Wheels

With Precision Ball Bearings for Any Application

Nylacron™ wheels with proper sized precision bearings are made to fit in any rig hub length and axle size. Nylacron™ wheels have greater load capacity ratings with better rollability while requiring less maintenance and have a longer life.

**SEE NYLACRON™ WHEEL SECTION
FOR CUSTOM SIZES & SHAPES.**

BRAKES OPTIONS



Poly Cam
specify P



PLB Integrated
specify PLB



Single Sided specify SSB310
Double Sided specify DSB310



Face Contact
specify FBB



**Hand Operated
Swivel Lock**
specify SL3000000

TYPICAL APPLICATIONS

- Conveyor-drawn tow-trucks
- Heavy duty bakery racks
- Production dollies
- Heavy duty dough troughs

WHEEL BEARING OPTIONS

- Straight Roller (01)
- Tapered Roller (09)
- Precision Ball (28)

7 410 KINGPINLESS CASTERS

NY/MD WHEELS

NYLACRON™ WHEELS

- Precision Machined from Cast Polyamide Hardness 112-120 Rockwell R.
- Ultimate choice for Extremely High Load applications to replace metallic wheels.
- Offer very high abrasion resistance and very low rolling resistance under extreme loads.

- Resistant to salt, grease, alcohol and mild acids - can be used in corrosive applications with appropriate bearings.
- Precision Ball Bearings.
- Temperature Range: -40°F to +270°F.

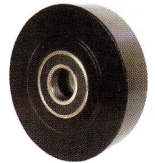

| Part Number Swivel Caster | Part Number Rigid Caster | Wheel Diameter (inch) | Tread Width (inch) | Load Capacity (lbs) | Overall Height (inch) | Swivel Radius (inch) | Swivel Radius w/Total Lock (inch) | Swivel Radius w/Wheel Brake (inch) |
|---------------------------|--------------------------|-----------------------|--------------------|---------------------|-----------------------|----------------------|-----------------------------------|------------------------------------|
| 410S63NYMD | 410R63NYMD | 6 | 3 | 4100 | 7-1/2 | 5-1/2 | 6 | 10-1/2 |
| 410S83NYMD | 410R83NYMD | 8 | 3 | 4100 | 10-1/8 | 6-1/2 | 6-1/2 | 11-1/2 |
| 410S103NYMD | 410R103NYMD | 10 | 3 | 4100 | 11-1/2 | 7-3/4 | 7-3/4 | 12-3/4 |
| 410S123NYMD | 410R123NYMD | 12 | 3 | 4100 | 13-1/2 | 9-1/4" | 9-1/4 | 14-1/4 |

NY/MC WHEELS

NYLACRON™ WHITE WHEELS

- Precision Machined from Cast Polyamide Hardness 112-120 Rockwell R.
- Ultimate choice for Extremely High Load applications to replace metallic wheels.
- Offer very high abrasion resistance and very low rolling resistance under extreme loads.

- Resistant to salt, grease, alcohol and mild acids - can be used in corrosive applications with appropriate bearings.
- Precision Ball Bearings.
- Temperature Range: -40°F to +270°F.



| Part Number Swivel Caster | Part Number Rigid Caster | Wheel Diameter (inch) | Tread Width (inch) | Load Capacity (lbs) | Overall Height (inch) | Swivel Radius (inch) | Swivel Radius w/Total Lock (inch) | Swivel Radius w/Wheel Brake (inch) |
|---------------------------|--------------------------|-----------------------|--------------------|---------------------|-----------------------|----------------------|-----------------------------------|------------------------------------|
| 410S63NYMC | 410R63NYMC | 6 | 3 | 4100 | 7-1/2 | 5-1/2 | 6 | 10-1/2 |
| 410S83NYMC | 410R83NYMC | 8 | 3 | 4100 | 10-1/8 | 6-1/2 | 6-1/2 | 11-1/2 |
| 410S103NYMC | 410R103NYMC | 10 | 3 | 4100 | 11-1/2 | 7-3/4 | 7-3/4 | 12-3/4 |
| 410S123NYMC | 410R123NYMC | 12 | 3 | 4100 | 13-1/2 | 9-1/4 | 9-1/4 | 14-1/4 |

DF WHEELS

DROP FORGED STEEL WHEELS

- AISI 1045 steel with machined tread faces.
- Virtually indestructible and easy to maneuver.
- High abrasion and oil resistant.

- Can be use in the roughest of applications on the poorest of floors.
- Precision Ball Bearings.
- Temperature Range: -150°F to +800°F.

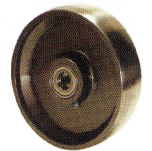

| Part Number Swivel Caster | Part Number Rigid Caster | Wheel Diameter (inch) | Tread Width (inch) | Load Capacity (lbs) | Overall Height (inch) | Swivel Radius (inch) | Swivel Radius w/Total Lock (inch) | Swivel Radius w/Wheel Brake (inch) |
|---------------------------|--------------------------|-----------------------|--------------------|---------------------|-----------------------|----------------------|-----------------------------------|------------------------------------|
| 410S63DF | 410R63DF | 6 | 3 | 4000 | 7-1/2 | 5-1/2 | 6 | 10-1/2 |
| 410S83DF | 410R83DF | 8 | 3 | 4000 | 10-1/8 | 6-1/2 | 6-1/2 | 11-1/2 |
| 410S103DF | 410R103DF | 10 | 3 | 4000 | 11-1/2 | 7-3/4 | 7-3/4 | 12-3/4 |
| 410S123DF | 410R123DF | 12 | 3 | 4000 | 13-1/2 | 9-1/4" | 9-1/4 | 14-1/4 |

7 410 KINGPINLESS CASTERS

SJS WHEELS

POLYURETHANE WHEELS

- Polyurethane tread wheels firmly bonded to Precision Machined Cast Iron Core.
- 93 + 3 Shore A.
- Low rolling resistance; Smooth and noiseless running.
- Non-marking and floor protective.

- Good Abrasion and cut resistance.
- Ideal for medium duty applications.
- Precision Ball Bearings.
- Temperature Range: -40°F to +180°F.
- Available in Anti-Static add "AS" after wheel.

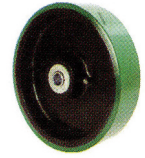

| Part Number Swivel Caster | Part Number Rigid Caster | Wheel Diameter (inch) | Tread Width (inch) | Load Capacity (lbs) | Overall Height (inch) | Swivel Radius (inch) | Swivel Radius w/Total Lock (inch) | Swivel Radius w/Wheel Brake (inch) |
|---------------------------|--------------------------|-----------------------|--------------------|---------------------|-----------------------|----------------------|-----------------------------------|------------------------------------|
| 410S63SJS | 410R63SJS | 6 | 3 | 2100 | 7-1/2 | 5-1/2 | 6 | 10-1/2 |
| 410S83SJS | 410R83SJS | 8 | 3 | 2500 | 10-1/8 | 6-1/2 | 6-1/2 | 11-1/2 |
| 410S103SJS | 410R103SJS | 10 | 3 | 3000 | 11-1/2 | 7-3/4 | 7-3/4 | 12-3/4 |
| 410S123SJS | 410R123SJS | 12 | 3 | 3500 | 13-1/2 | 9-1/4 | 9-1/4 | 14-1/4 |

MDW WHEELS

DUCTILE CAST STEEL WHEELS

- Machined tread face.
- Crown tread Face makes maneuverability easy.
- Higher Load Capacities compared to Cast Iron Wheels.

- Suitable for extra heavy loads towed in punishing conditions.
- High abrasion and oil resistance.
- Precision Ball Bearings.
- Temperature Range: 800°F.

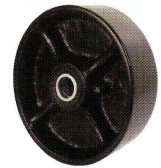

| Part Number Swivel Caster | Part Number Rigid Caster | Wheel Diameter (inch) | Tread Width (inch) | Load Capacity (lbs) | Overall Height (inch) | Swivel Radius (inch) | Swivel Radius w/Total Lock (inch) | Swivel Radius w/Wheel Brake (inch) |
|---------------------------|--------------------------|-----------------------|--------------------|---------------------|-----------------------|----------------------|-----------------------------------|------------------------------------|
| 410S63MDW | 410R63MDW | 6 | 3 | 3300 | 7-1/2 | 5-1/2 | 6 | 10-1/2 |
| 410S83MDW | 410R83MDW | 8 | 3 | 4000 | 10-1/8 | 6-1/2 | 6-1/2 | 11-1/2 |
| 410S103MDW | 410R103MDW | 10 | 3 | 4000 | 11-1/2 | 7-3/4 | 7-3/4 | 12-3/4 |
| 410S123MDW | 410R123MDW | 12 | 3 | 4000 | 13-1/2 | 9-1/4" | 9-1/4 | 14-1/4 |

ME WHEELS

ERGONOMIC POLYURETHANE DONUT TREAD WHEELS CAST IRON CORE

- For Low Push-Pull Efforts.
- Polyurethane firmly bonded to Precision Machined Cast Iron Core.
- Red Tread 93+ 3 Shore A.
- Non-marking and floor protective.

- Tread Options:
Softer 80A - Yellow Tread (specify ME-Z)
Harder 73D - Blue Tread (specify ME-F).
- Precision Ball Bearings.
- Temperature Range: -40°F to +180°F.
- Available in Anti-Static add "AS" after wheel.



| Part Number Swivel Caster | Part Number Rigid Caster | Wheel Diameter (inch) | Tread Width (inch) | Load Capacity (lbs) | Overall Height (inch) | Swivel Radius (inch) | Swivel Radius w/Total Lock (inch) | Swivel Radius w/Wheel Brake (inch) |
|---------------------------|--------------------------|-----------------------|--------------------|---------------------|-----------------------|----------------------|-----------------------------------|------------------------------------|
| 410S63ME | 410R63ME | 6 | 3 | 2300 | 7-1/2 | 5-1/2 | 6 | 10-1/2 |
| 410S83ME | 410R83ME | 8 | 3 | 3100 | 10-1/8 | 6-1/2 | 6-1/2 | 11-1/2 |
| 410S103ME | 410R103ME | 10 | 3 | 4000 | 11-1/2 | 7-3/4 | 7-3/4 | 12-3/4 |
| 410S123ME | 410R123ME | 12 | 3 | 4000 | 13-1/2 | 9-1/4 | 9-1/4 | 14-1/4 |

MEGALOAD™ AND VULKOLLAN™ WHEELS WITH PRECISION BALL BEARINGS AVAILABLE TO FIT THIS CASTER SERIES.
SIZES 6 X 3, 8 X 3, 10 X 3 & 12 X 3.

7 415 KINGPINLESS DUAL WHEEL SERIES CASTERS



5,400 LBS. LOAD CAPACITY KINGPINLESS TYPE CASTERS

- **Raceway Design:** Patented Kinpinless single ball bearing precision machined raceway hardened to 53 Rockwell C minimum. Swivel section features a 3" diameter raceway with 1/2" ball bearings. The notched yoke is standard.
- **Finish:** Laguna Blue paint.
- **Yoke Base:** Harden C1040 steel.
- **Legs:** 3/8" formed steel. Center leg support is added for increased strength.
- **Wheels:** All wheels are 3" wide with precision bearings for minimal maintenance.
- **Axle:** 3/4" bolt, locking nut and lubrication fittings.
- Alternate or custom caster configurations available.

BRAKES OPTIONS



Poly Cam
specify P



Hand Operated Swivel Lock
specify L

To order a rigid caster, change the "S" to "R" in the model number. Dimensions shown are nominal. If precise dimensions are required, consult Acorn™. For approximate weight of our rigid casters, deduct 3.9 pounds.

All bearings are precision ball bearings with heavy-duty end caps.

MOUNTING PLATE OPTIONS

TOP PLATE:

Plate Size: 5-1/4" x 7-1/4"

Bolt Holes: 6-1/8" x 4-1/2"

Slotted: 6" x 4-1/8"

Bolt Size: 1/2"

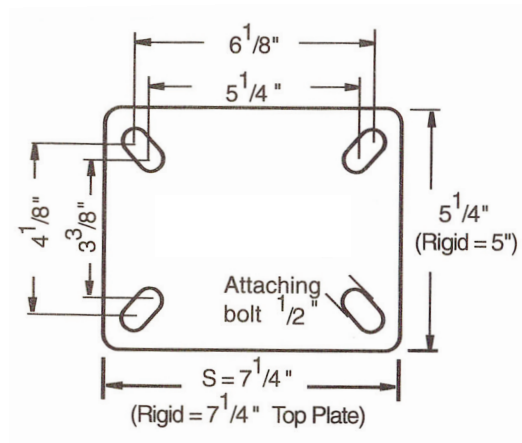

7 415 KINGPINLESS DUAL WHEEL SERIES CASTERS

NY/MD WHEELS

NYLACRON™ WHEELS

- Precision Machined from Cast Polyamide Hardness 112-120 Rockwell R.
- Ultimate choice for Extremely High Load applications to replace metallic wheels.
- Offer very high abrasion resistance and very low rolling resistance under extreme loads.

- Resistant to salt, grease, alcohol and mild acids - can be used in corrosive applications with appropriate bearings.
- Precision Ball Bearings.
- Temperature Range: -40°F to +270°F.

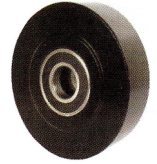

| Part Number Swivel Caster | Part Number Rigid Caster | Wheel Diameter (inch) | Tread Width (inch) | Load Capacity (lbs) | Overall Height (inch) | Swivel Lead (inch) |
|---------------------------|--------------------------|-----------------------|--------------------|---------------------|-----------------------|--------------------|
| 415S63NYMD | 415R63NYMD | 6 | 3 | 5400 | 8-1/2 | 2.25 |
| 415S83NYMD | 415R83NYMD | 8 | 3 | 5400 | 10-1/2 | 2.75 |
| 415S103NYMD | 415R103NYMD | 10 | 3 | 5400 | 12-1/2 | 3.38 |
| 415S123NYMD | 415R123NYMD | 12 | 3 | 5400 | 15-1/2 | 4.13 |

**MEGALOAD™ AND VULKOLLAN™ WHEELS WITH PRECISION BALL BEARINGS AVAILABLE TO FIT THIS CASTER SERIES.
SIZES 6 X 3, 8 X 3, 10 X 3 & 12 X 3.**

7 S410 SPRING LOADED CASTERS

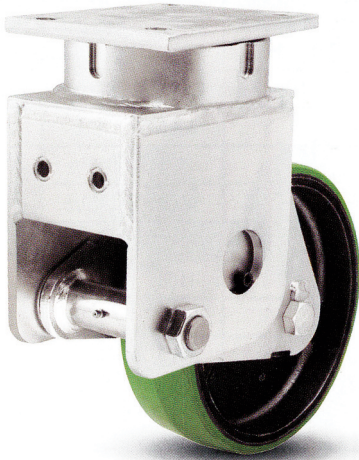

3,000 LBS. LOAD CAPACITY KINGPINLESS TYPE CASTERS

- **Load Springs:** Different load springs for each series permits wide variation in ride “softness”.
- **Complete Line:** Available on all 7KSL models.
- **Swivel Section:** Kingpinless design. Ball bearing mounted in a machined raceway.
- **Axle:** 3/4” diameter standard. Optional 1” diameter available.
- Alternate or custom caster configurations available.
- Brake options available.

Our newly designed spring loaded casters offer greater capacity and protection from damaging shock or unwanted vibration and movement. Noise levels are reduced through the dampening effect of these casters.

We offer many custom spring loaded solutions for the automotive and aviation industry.

TYPICAL APPLICATIONS

- Aviation ground support
- Aircraft tripod jacks
- Portable medical equipment
- Computer equipment
- Shock sensitive loads

MOUNTING PLATE OPTIONS

TOP PLATE: (STANDARD)

Plate Size: 4-1/2” x 6-1/4”

Bolt Holes: 2-7/16” x 4-15/16”
slotted to
3-3/8” x 5-1/4”

Bolt Size: 1/2”

Special order top plates

(PATK) 6-1/4” x 4-1/4”

(PATR) 7-1/2” x 6-1/4”

(PATS) 7” x 6”

7 S410 SPRING LOADED CASTERS

NYLACRON™ WHEELS PRECISION BALL BEARINGS NY/MD

| Part Number Swivel Caster | Part Number Rigid Caster | Wheel Diameter (inch) | Tread Width (inch) | Load Capacity (lbs) | Overall Height (inch) | Swivel Lead (inch) |
|---------------------------------|--------------------------------|-----------------------------|--------------------------|---------------------------|-----------------------------|--------------------------|
| S410S63NYMD | S410R63NYMD | 6 | 3 | 3000 | 7-1/2 | 1-3/8 |
| S410S83NYMD | S410R83NYMD | 8 | 3 | 3000 | 10-1/8 | 2-1/16 |
| S410S103NYMD | S410R103NYMD | 10 | 3 | 3000 | 11-1/2 | 2-1/4 |
| S410S123NYMD | S410R123NYMD | 12 | 3 | 3000 | 13-1/2 | 2-11/16 |

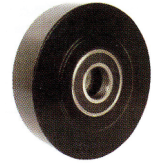

POLYURETHANE TREAD ON CAST IRON PRECISION BALL BEARINGS PF

| Part Number Swivel Caster | Part Number Rigid Caster | Wheel Diameter (inch) | Tread Width (inch) | Load Capacity (lbs) | Overall Height (inch) | Swivel Lead (inch) |
|---------------------------------|--------------------------------|-----------------------------|--------------------------|---------------------------|-----------------------------|--------------------------|
| S410S63PF | S410R63PF | 6 | 3 | 3000 | 7-1/2 | 1-3/8 |
| S410S83PFS | S410R83PF | 8 | 3 | 3000 | 10-1/8 | 2-1/16 |
| S410S103PFS | S410R103PF | 10 | 3 | 3000 | 11-1/2 | 2-1/4 |
| S410S123PFS | S410R123PF | 12 | 3 | 3000 | 13-1/2 | 2-11/16 |



SWIVEL-EAZ™ 95A CROWN TREAD PRECISION BALL BEARINGS SWE/CT

• Crown tread also available in 70A, 80A, 60D & 75D durometer.

• See wheel section.

| Part Number Swivel Caster | Part Number Rigid Caster | Wheel Diameter (inch) | Tread Width (inch) | Load Capacity (lbs) | Overall Height (inch) | Swivel Lead (inch) |
|---------------------------------|--------------------------------|-----------------------------|--------------------------|---------------------------|-----------------------------|--------------------------|
| S410S63SWECT | S410R63SWECT | 6 | 3 | 2137 | 10-7/8 | 4-7/8 |
| S410S83SWECT | S410R83SWECT | 8 | 3 | 3000 | 11-7/8 | 4-7/8 |



SWIVEL-EAZ™ 95A FLAT TREAD PRECISION BALL BEARINGS SWE/FT

• Flat tread also available in 70A, 80A, 60D & 75D durometer.

• See wheel section.

| Part Number Swivel Caster | Part Number Rigid Caster | Wheel Diameter (inch) | Tread Width (inch) | Load Capacity (lbs) | Overall Height (inch) | Swivel Lead (inch) |
|---------------------------------|--------------------------------|-----------------------------|--------------------------|---------------------------|-----------------------------|--------------------------|
| S410S63SWEFT | S410R63SWEFT | 6 | 3 | 2850 | 10-7/8 | 4-7/8 |
| S410S83SWEFT | S410R83SWEFT | 8 | 3 | 3000 | 11-7/8 | 4-7/8 |
| S410S103SWEFT | S410R103SWEFT | 10 | 3 | 3000 | 14 | 4-7/8 |



MEGALOAD™ AND VULKOLLAN™ WHEELS WITH PRECISION BALL BEARINGS AVAILABLE TO FIT THIS CASTER SERIES.
SIZES 6 X 3, 8 X 3, 10 X 3 & 12 X 3.