

**Caster Type****Page**

GRDU Total Lock Kingpinless Series Casters.....	2-4
GRDU Kingpinless Stainless Steel Casters.....	5-6
310 Kingpinless Casters.....	7-10
S310 Spring Loaded Casters.....	11-12

**ALL WHEELS ARE AVAILABLE WITH
PRECISION BALL BEARING, CENTERPIECE & END CAPS
FOR MANUAL OR TOWING TO FIT IN 3-1/2" HUB LENGTH RIGS.
See Wheel Section for complete selection.**

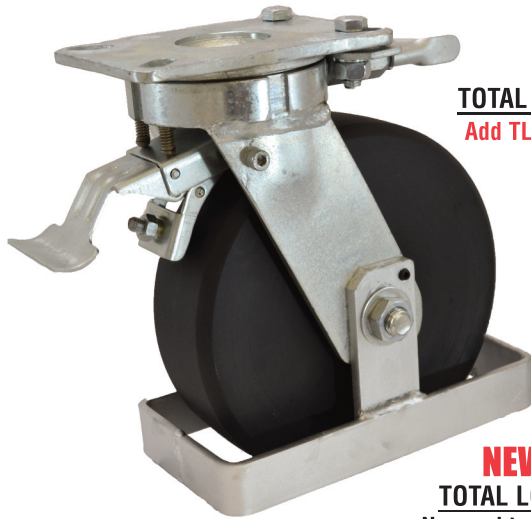

**LEADING SIDE
TOTAL LOCK SWIVEL CASTER**
Add TL to swivel caster number

Available Toe Guard
TO

**NEW TRAILING SIDE
TOTAL LOCK SWIVEL CASTER**
No need to move cots back and forth
for finding the brake pedal.
Add TLN to swivel caster number

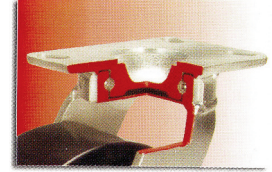

Swivel Head Section

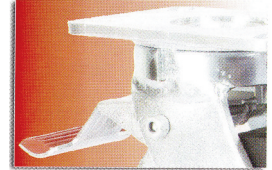

Total Lock System

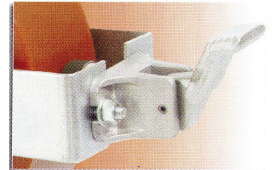

Wheel Face Brake

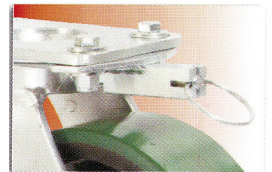

Directional Lock

4,000 LBS. LOAD CAPACITY FORGED KINGPINLESS TYPE CASTERS

- Single piece Drop Forged AISI 1045 Steel Top Plate and Fork Base.
- Precision CNC Machined Raceways with 3" diameter with 1/2" ball bearings.
- Induction Hardening of Raceways ensures uniform depth of hardness.
- Totally Sealed Swivel Head with Grease Nipple.
- 5/16" Thick Fork Legs Robotically welded Inside & Outside to 3 1/2" fork spacing.
- 3/4" Wheel axle.
- 4 Position Directional Lock Slots.
- Finish: Bright Zinc Plated.

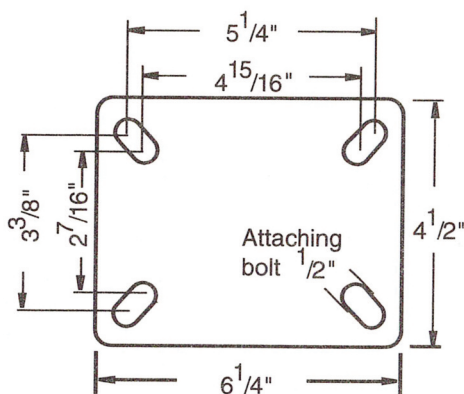

TOP PLATE
4-1/2 X 6-1/4

BOLT HOLE CENTER
3-3/8 X 5-1/4
SLOTTED TO
2-7/16 X 4-15/16

ATTACHING BOLT SIZE
1/2

RIG OPTIONS
DL: 4-WAY DIRECTIONAL LOCK

WFB: WHEEL FACE BRAKE
ADD TO SUFFIX
OF THE CASTER PART NUMBER

TOE GUARDS
SPECIFY "TO"
WITH CASTER NUMBER

NY/MD WHEELS

NYLACRON™ WHEELS

- Precision Machined from Cast Polyamide Hardness 112-120 Rockwell R.
- Ultimate choice for Extremely High Load applications to replace metallic wheels.
- Offer very high abrasion resistance and very low rolling resistance under extreme loads.

- Resistant to salt, grease, alcohol and mild acids - can be used in corrosive applications with appropriate bearings.
- Precision Ball Bearings.
- Temperature Range: -40°F to +270°F.

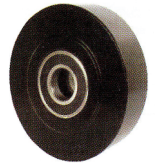

Part Number Swivel Caster	Part Number Swivel with Total Lock	Part Number Rigid Caster	Wheel Diameter (inch)	Tread Width (inch)	Load Capacity (lbs)	Overall Height (inch)	Swivel Radius (inch)	Swivel Radius w/Total Lock (inch)	Swivel Radius w/Wheel Brake (inch)
GRDUS63NYMD	GRDUTL63NYMD	GRDUR63NYMD	6	3	4000	7-1/2	5-1/2	6	10-1/2
GRDUS83NYMD	GRDUTL83NYMD	GRDUR83NYMD	8	3	4000	10-1/8	6-1/2	6-1/2	11-1/2
GRDUS103NYMD	GRDUTL103NYMD	GRDUR103NYMD	10	3	4000	11-1/2	7-3/4	7-3/4	12-3/4
GRDUS123NYMD	GRDUTL123NYMD	GRDUR123NYMD	12	3	4000	13-1/2	9-1/4	9-1/4	14-1/4

NY/MC WHEELS

NYLACRON™ WHITE WHEELS

- Precision Machined from Cast Polyamide Hardness 112-120 Rockwell R.
- Ultimate choice for Extremely High Load applications to replace metallic wheels.
- Offer very high abrasion resistance and very low rolling resistance under extreme loads.

- Resistant to salt, grease, alcohol and mild acids - can be used in corrosive applications with appropriate bearings.
- Precision Ball Bearings.
- Temperature Range: -40°F to +270°F.



Part Number Swivel Caster	Part Number Swivel with Total Lock	Part Number Rigid Caster	Wheel Diameter (inch)	Tread Width (inch)	Load Capacity (lbs)	Overall Height (inch)	Swivel Radius (inch)	Swivel Radius w/Total Lock (inch)	Swivel Radius w/Wheel Brake (inch)
GRDUS63NYMC	GRDUTL63NYMC	GRDUR63NYMC	6	3	4000	7-1/2	5-1/2	6	10-1/2
GRDUS83NYMC	GRDUTL83NYMC	GRDUR83NYMC	8	3	4000	10-1/8	6-1/2	6-1/2	11-1/2
GRDUS103NYMC	GRDUTL103NYMC	GRDUR103NYMC	10	3	4000	11-1/2	7-3/4	7-3/4	12-3/4
GRDUS123NYMC	GRDUTL123NYMC	GRDUR123NYMC	12	3	4000	13-1/2	9-1/4	9-1/4	14-1/4

SZS WHEELS

ELASTIC POLYURETHANE TREAD WHEELS CAST IRON CORE

- Polyurethane firmly bonded to Precision Machined Cast Iron Core
- 85+ 3 Shore A
- Excellent for power towing applications

- Reduced noise due to cushioning of loads, Lively Polyurethane allows wheels to “Flex and Roll” over debris
- Non-marking and floor protective
- Precision Ball Bearings
- Temperature Range: -40°F to +180°F
- Available in Anti-Static add “AS” after wheel



Part Number Swivel Caster	Part Number Swivel with Total Lock	Part Number Rigid Caster	Wheel Diameter (inch)	Tread Width (inch)	Load Capacity (lbs)	Overall Height (inch)	Swivel Radius (inch)	Swivel Radius w/Total Lock (inch)	Swivel Radius w/Wheel Brake (inch)
GRDU62SSZS	GRDU62SSZSTL	GRDU62RSZS	6	3	1750	8	5-1/8	6	10-1/8
GRDU82SSZS	GRDU82SSZSTL	GRDU82RSZS	8	3	2400	10-1/2	6-1/4	6-1/4	11-1/4
GRDU102SSZS	GRDU102SSZSTL	GRDU102RSZS	10	3	3100	12-1/2	7-3/4	7-3/4	12-3/4
GRDU122SSZS	GRDU122SSZSTL	GRDU122RSZS	12	3	3500	15-1/2	8-3-8	8-3-8	13-3/8

SAS WHEELS

HIGH CAPACITY POLYURETHANE
TREAD WHEELS CAST IRON CORE

- Polyurethane firmly bonded to Precision Machined Cast Iron Core
- 93+ 3 Shore A
- Low rolling resistance, smooth and noiseless running

- Non-marking and floor protective
- High abrasion, cut and tear resistant
- Precision Ball Bearings
- Temperature Range: -40°F to +180°F
- Available in Anti-Static add "AS" after wheel



Part Number Swivel Caster	Part Number Swivel with Total Lock	Part Number Rigid Caster	Wheel Diameter (inch)	Tread Width (inch)	Load Capacity (lbs)	Overall Height (inch)	Swivel Radius (inch)	Swivel Radius w/Total Lock (inch)	Swivel Radius w/Wheel Brake (inch)
GRDU62SSAS	GRDU62SSASTL	GRDU62RSAS	6	3	1750	8	5-1/8	6	10-1/8
GRDU82SSAS	GRDU82SSASTL	GRDU82RSAS	8	3	2400	10-1/2	6-1/4	6-1/4	11-1/4
GRDU102SSAS	GRDU102SSASTL	GRDU102RSAS	10	3	3100	12-1/2	7-3/4	7-3/4	12-3/4
GRDU122SSAS	GRDU122SSASTL	GRDU122RSAS	12	3	3500	15-1/2	8-3-8	8-3-8	13-3/8

SJS WHEELS

POLYURETHANE WHEELS

- Polyurethane tread wheels firmly bonded to Precision Machined Cast Iron Core.
- 93 + 3 Shore A.
- Low rolling resistance; Smooth and noiseless running.
- Non-marking and floor protective.

- Good Abrasion and cut resistance.
- Ideal for medium duty applications.
- Precision Ball Bearings.
- Temperature Range: -40°F to +180°F.
- Available in Anti-Static add "AS" after wheel.

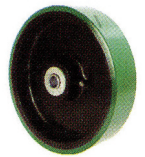

Part Number Swivel Caster	Part Number Swivel with Total Lock	Part Number Rigid Caster	Wheel Diameter (inch)	Tread Width (inch)	Load Capacity (lbs)	Overall Height (inch)	Swivel Radius (inch)	Swivel Radius w/Total Lock (inch)	Swivel Radius w/Wheel Brake (inch)
GRDU62SSJS	GRDU62SSJSTL	GRDU62RSJS	6	3	1750	8	5-1/8	6	10-1/8
GRDU82SSJS	GRDU82SSJSTL	GRDU82RSJS	8	3	2400	10-1/2	6-1/4	6-1/4	11-1/4
GRDU102SSJS	GRDU102SSJSTL	GRDU102RSJS	10	3	3100	12-1/2	7-3/4	7-3/4	12-3/4
GRDU122SSJS	GRDU122SSJSTL	GRDU122RSJS	12	3	3500	15-1/2	8-3-8	8-3-8	13-3/8

ME WHEELS

ERGONOMIC POLYURETHANE
DONUT TREAD WHEELS CAST IRON CORE

- For Low Push-Pull Efforts.
- Polyurethane firmly bonded to Precision Machined Cast Iron Core.
- Red Tread 93+ 3 Shore A.
- Non-marking and floor protective.

- Tread Options:
Softer 80A - Yellow Tread (specify ME-Z)
Harder 73D - Blue Tread (specify ME-F).
- Precision Ball Bearings.
- Temperature Range: -40°F to +180°F.
- Available in Anti-Static add "AS" after wheel.



Part Number Swivel Caster	Part Number Swivel with Total Lock	Part Number Rigid Caster	Wheel Diameter (inch)	Tread Width (inch)	Load Capacity (lbs)	Overall Height (inch)	Swivel Radius (inch)	Swivel Radius w/Total Lock (inch)	Swivel Radius w/Wheel Brake (inch)
GRDU62SME	GRDU62SMETL	GRDU62RME	6	3	1750	8	5-1/8	6	10-1/8
GRDU82SME	GRDU82SMETL	GRDU82RMES	8	3	2400	10-1/2	6-1/4	6-1/4	11-1/4
GRDU102SME	GRDU102SMETL	GRDU102RME	10	3	3100	12-1/2	7-3/4	7-3/4	12-3/4
GRDU122SME	GRDU122SMETL	GRDU122RME	12	3	3500	15-1/2	8-3-8	8-3-8	13-3/8

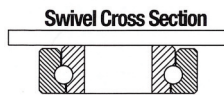

3,000 LBS. LOAD CAPACITY STAINLESS STEEL KINGPINLESS TYPE CASTERS

- **Top Plate:** 5/16" 304 stainless steel welded inside and out to 316 stainless steel raceway for longer life.
- **Swivel Section:** One row of 1/2" ball bearings mounted in a precision machined raceway. Zerk in swivel section.
- **Yoke Base:** Notched 316 stainless steel.
- **Legs:** 304 stainless steel welded inside and out.
- **Axle:** 3/4" diameter.
- Alternate or custom caster configurations available.

BRAKES OPTIONS



Poly Cam
specify **P**



Single Sided specify **SSB310**
Double Sided specify **DSB310**



Face Contact
specify **FBB**



Hand Operated Swivel Lock
specify **SL3000000**

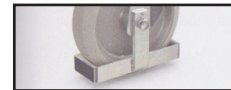

TOE GUARDS AVAILABLE WITH ALL CASTERS.

Designed from premium grade 304 stainless steel caster rig with a strong premium 316 stainless swivel section. Excellent finish to protect caster from cleaning agents, steam, caustic solutions, or other corrosive agents which can cause rust.

TYPICAL APPLICATIONS

- Conveyor-drawn tow-trucks
- Heavy duty bakery racks
- Production dollies
- Heavy duty dough troughs

MOUNTING PLATE OPTIONS

TOP PLATE: (STANDARD)

Plate Size: 4-1/2 X 6-1/4
Bolt Holes: 2-7/16 x 4-15/16
slotted to
3-3/8 x 5-1/4
Bolt Size: 1/2

TOP PLATE: D

Plate Size: 5 x 5-1/2
Bolt Holes: 4-1/8 x 4-1/2
Bolt Size: 3/8

BEARING OPTIONS

Straight Roller **(01)**
Precision Ball **(28)**

*Add options to end of part number.

**NYLACRON™
CAST NYLON
28 PRECISION BEARING
NY/MD**

FOR MONOCAST
MC/MD

Part Number Swivel Caster	Part Number Rigid Caster	Wheel Diameter (inch)	Tread Width (inch)	Load Capacity (lbs)	Overall Height (inch)	Swivel Lead (inch)
GRDUSS63NYMD	GRDUSR63NYMD	6	3	3000	7-1/2	1-3/8
GRDUSS83NYMD	GRDUSR83NYMD	8	3	3000	10-1/8	2-1/16
GRDUSS103NYMD	GRDUSR103NYMD	10	3	3000	11-1/2	2-1/4
GRDUSS123NYMD	GRDUSR123NYMD	12	3	3000	13-1/2	2-11/16

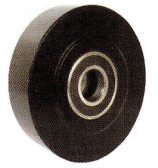

**X-TREME
PLUS SOLID POLYURETHANE
28 PRECISION BEARING
XP**

• Prevenz™ antimicrobial models available

• Add PREV to end of caster number

Part Number Swivel Caster	Part Number Rigid Caster	Wheel Diameter (inch)	Tread Width (inch)	Load Capacity (lbs)	Overall Height (inch)	Swivel Lead (inch)
GRDUSS83XP	GRDUSSR83XP	8	3	2000	10-1/8	2-1/16
GRDUSS103XP	GRDUSSR103XP	10	3	2500	11-1/2	2-1/4



**PHENOLIC
01 ROLLER BEARING
TM**

• Prevenz™ antimicrobial models available

• Add PREV to end of caster number

• Tapered Roller 09 Bearings available

• Change "01" to "09"
Example: 6KSSS63TM09

Part Number Swivel Caster	Part Number Rigid Caster	Wheel Diameter (inch)	Tread Width (inch)	Load Capacity (lbs)	Overall Height (inch)	Swivel Lead (inch)
GRDUSS63TM	GRDUSSR63TM	6	3	2000	7-1/2	1-3/8
GRDUSS83TM	GRDUSSR83TM	8	3	2500	10-1/8	2-1/16
GRDUSS103TM	GRDUSSR103TM	10	3	2900	11-1/2	2-1/4
GRDUSS123TM	GRDUSSR123TM	12	3	3000	13-1/2	2-11/16



MEGALOAD™ AND VULKOLLAN™ WHEELS WITH PRECISION BALL BEARINGS AVAILABLE TO FIT THIS CASTER SERIES.

SIZES 6 X 3, 8 X 3, 10 X 3 & 12 X 3.

6 310 KINGPINLESS CASTERS

4,100 LBS. LOAD CAPACITY KINGPINLESS TYPE CASTERS

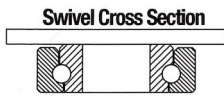

- **Top Plate:** 5/16" AISI 1045 heat treated steel welded inside and out for longer life.
- **Swivel Section:** One row of 1/2" ball bearings mounted in a heat treated precision machined raceway. Zerk in swivel section.
- **Yoke Base:** Notched AISI 1045 steel.
- **Legs:** 3/8" thick welded inside and out.
- **Axle:** 3/4" diameter.
- **Finish:** RoHS Zinc plating, for greater corrosion resistance than paint.



**TOE GUARDS
AVAILABLE WITH
ALL CASTERS.**

MOUNTING PLATE OPTIONS

TOP PLATE: (STANDARD)

- Plate Size:** 4-1/2" x 6-1/4"
- Bolt Holes:** 2-7/16" x 4-15/16"
slotted to
3-3/8" x 5-1/4"
- Bolt Size:** 1/2"

Nylacron™ Wheels

With Precision Ball Bearings for Any Application

Nylacron™ wheels with proper sized precision bearings are made to fit in any rig hub length and axle size. Nylacron™ wheels have greater load capacity ratings with better rollability while requiring less maintenance and have a longer life.

**SEE NYLACRON™ WHEEL SECTION
FOR CUSTOM SIZES & SHAPES.**

BRAKES OPTIONS



Poly Cam
specify **P**



PLB Integrated
specify **PLB**



Single Sided specify **SSB310**
Double Sided specify **DSB310**



Face Contact
specify **FBB**



**Hand Operated
Swivel Lock**
specify **SL3000000**

TYPICAL APPLICATIONS

- Conveyor-drawn tow-trucks
- Heavy duty bakery racks
- Production dollies
- Heavy duty dough troughs

WHEEL BEARING OPTIONS

- Straight Roller **(01)**
- Tapered Roller **(09)**
- Precision Ball **(28)**

NY/MD WHEELS

NYLACRON™ WHEELS

- Precision Machined from Cast Polyamide Hardness 112-120 Rockwell R.
- Ultimate choice for Extremely High Load applications to replace metallic wheels.
- Offer very high abrasion resistance and very low rolling resistance under extreme loads.

- Resistant to salt, grease, alcohol and mild acids - can be used in corrosive applications with appropriate bearings.
- Precision Ball Bearings.
- Temperature Range: -40°F to +270°F.

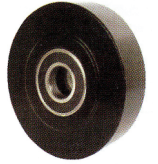

Part Number Swivel Caster	Part Number Rigid Caster	Wheel Diameter (inch)	Tread Width (inch)	Load Capacity (lbs)	Overall Height (inch)	Swivel Radius (inch)	Swivel Radius w/Total Lock (inch)	Swivel Radius w/Wheel Brake (inch)
310S63NYMD	310R63NYMD	6	3	4100	7-1/2	5-1/2	6	10-1/2
310S83NYMD	310R83NYMD	8	3	4100	10-1/8	6-1/2	6-1/2	11-1/2
310S103NYMD	310R103NYMD	10	3	4100	11-1/2	7-3/4	7-3/4	12-3/4
310S123NYMD	310R123NYMD	12	3	4100	13-1/2	9-1/4"	9-1/4	14-1/4

NY/MC WHEELS

NYLACRON™ WHITE WHEELS

- Precision Machined from Cast Polyamide Hardness 112-120 Rockwell R.
- Ultimate choice for Extremely High Load applications to replace metallic wheels.
- Offer very high abrasion resistance and very low rolling resistance under extreme loads.

- Resistant to salt, grease, alcohol and mild acids - can be used in corrosive applications with appropriate bearings.
- Precision Ball Bearings.
- Temperature Range: -40°F to +270°F.



Part Number Swivel Caster	Part Number Rigid Caster	Wheel Diameter (inch)	Tread Width (inch)	Load Capacity (lbs)	Overall Height (inch)	Swivel Radius (inch)	Swivel Radius w/Total Lock (inch)	Swivel Radius w/Wheel Brake (inch)
310S63NYMC	310R63NYMC	6	3	4100	7-1/2	5-1/2	6	10-1/2
310S83NYMC	310R83NYMC	8	3	4100	10-1/8	6-1/2	6-1/2	11-1/2
310S103NYMC	310R103NYMC	10	3	4100	11-1/2	7-3/4	7-3/4	12-3/4
310S123NYMC	310R123NYMC	12	3	4100	13-1/2	9-1/4	9-1/4	14-1/4

DF WHEELS

DROP FORGED STEEL WHEELS

- AISI 1045 steel with machined tread faces.
- Virtually indestructible and easy to maneuver.
- High abrasion and oil resistant.

- Can be use in the roughest of applications on the poorest of floors.
- Precision Ball Bearings.
- Temperature Range: -150°F to +800°F.

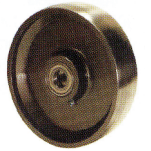

Part Number Swivel Caster	Part Number Rigid Caster	Wheel Diameter (inch)	Tread Width (inch)	Load Capacity (lbs)	Overall Height (inch)	Swivel Radius (inch)	Swivel Radius w/Total Lock (inch)	Swivel Radius w/Wheel Brake (inch)
310S63DF	310R63DF	6	3	4000	7-1/2	5-1/2	6	10-1/2
310S83DF	310R83DF	8	3	4000	10-1/8	6-1/2	6-1/2	11-1/2
310S103DF	310R103DF	10	3	4000	11-1/2	7-3/4	7-3/4	12-3/4
310S123DF	310R123DF	12	3	4000	13-1/2	9-1/4"	9-1/4	14-1/4

6 310 KINGPINLESS CASTERS

SJS WHEELS

POLYURETHANE WHEELS

- Polyurethane tread wheels firmly bonded to Precision Machined Cast Iron Core.
- 93 + 3 Shore A.
- Low rolling resistance; Smooth and noiseless running.
- Non-marking and floor protective.

- Good Abrasion and cut resistance.
- Ideal for medium duty applications.
- Precision Ball Bearings.
- Temperature Range: -40°F to +180°F.
- Available in Anti-Static add "AS" after wheel.

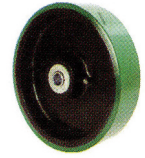

Part Number Swivel Caster	Part Number Rigid Caster	Wheel Diameter (inch)	Tread Width (inch)	Load Capacity (lbs)	Overall Height (inch)	Swivel Radius (inch)	Swivel Radius w/Total Lock (inch)	Swivel Radius w/Wheel Brake (inch)
310S63SJS	310R63SJS	6	3	2100	7-1/2	5-1/2	6	10-1/2
310S83SJS	310R83SJS	8	3	2500	10-1/8	6-1/2	6-1/2	11-1/2
310S103SJS	310R103SJS	10	3	3000	11-1/2	7-3/4	7-3/4	12-3/4
310S123SJS	310R123SJS	12	3	3500	13-1/2	9-1/4	9-1/4	14-1/4

MDW WHEELS

DUCTILE CAST STEEL WHEELS

- Machined tread face.
- Crown tread Face makes maneuverability easy.
- Higher Load Capacities compared to Cast Iron Wheels.

- Suitable for extra heavy loads towed in punishing conditions.
- High abrasion and oil resistance.
- Precision Ball Bearings.
- Temperature Range: 800°F.

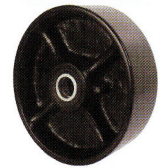

Part Number Swivel Caster	Part Number Rigid Caster	Wheel Diameter (inch)	Tread Width (inch)	Load Capacity (lbs)	Overall Height (inch)	Swivel Radius (inch)	Swivel Radius w/Total Lock (inch)	Swivel Radius w/Wheel Brake (inch)
310S63MDW	310R63MDW	6	3	3300	7-1/2	5-1/2	6	10-1/2
310S83MDW	310R83MDW	8	3	4000	10-1/8	6-1/2	6-1/2	11-1/2
310S103MDW	310R103MDW	10	3	4000	11-1/2	7-3/4	7-3/4	12-3/4
310S123MDW	310R123MDW	12	3	4000	13-1/2	9-1/4"	9-1/4	14-1/4

ME WHEELS

ERGONOMIC POLYURETHANE DONUT TREAD WHEELS CAST IRON CORE

- For Low Push-Pull Efforts.
- Polyurethane firmly bonded to Precision Machined Cast Iron Core.
- Red Tread 93+ 3 Shore A.
- Non-marking and floor protective.

- Tread Options:
Softer 80A - Yellow Tread (specify ME-Z)
Harder 73D - Blue Tread (specify ME-F).
- Precision Ball Bearings.
- Temperature Range: -40°F to +180°F.
- Available in Anti-Static add "AS" after wheel.



Part Number Swivel Caster	Part Number Rigid Caster	Wheel Diameter (inch)	Tread Width (inch)	Load Capacity (lbs)	Overall Height (inch)	Swivel Radius (inch)	Swivel Radius w/Total Lock (inch)	Swivel Radius w/Wheel Brake (inch)
310S63ME	310R63ME	6	3	2300	7-1/2	5-1/2	6	10-1/2
310S83ME	310R83ME	8	3	3100	10-1/8	6-1/2	6-1/2	11-1/2
310S103ME	310R103ME	10	3	4000	11-1/2	7-3/4	7-3/4	12-3/4
310S123ME	310R123ME	12	3	4000	13-1/2	9-1/4	9-1/4	14-1/4

6 310 KINGPINLESS CASTERS

DROP FORGED STEEL WHEELS 09 PRECISION TAPERED BEARING

FS

Part Number Swivel Caster	Part Number Rigid Caster	Wheel Diameter (inch)	Tread Width (inch)	Load Capacity (lbs)	Overall Height (inch)	Swivel Lead (inch)
310S63FS	310R63FS	6	3	4000	7-1/2	1-3/8
310S83FS	310R83FS	8	3	4100	10-1/8	2-1/16
310S103FS	310R103FS	10	3	4100	11-1/2	2-1/4



SWIVEL-EAZ™ ROUND TREAD 95A 28 PRECISION BALL BEARING

SWE95 ADD SUFFIX FT FOR FLAT TREAD

Part Number Swivel Caster	Part Number Rigid Caster	Wheel Diameter (inch)	Tread Width (inch)	Load Capacity (lbs)	Overall Height (inch)	Swivel Lead (inch)
310S63SWE95	310R63SWE95	6	3	1100	7-1/2	1-3/8
310S83SWE95	310R83SWE95	8	3	2400	10-1/8	2-1/16
310S103SWE95	310R103SWE95	10	3	3800	11-1/2	2-1/4



POLYURETHANE ON CAST IRON 28 PRECISION BALL BEARING

PF

Part Number Swivel Caster	Part Number Rigid Caster	Wheel Diameter (inch)	Tread Width (inch)	Load Capacity (lbs)	Overall Height (inch)	Swivel Lead (inch)
310S63PF	310R63PF	6	3	3000	7-1/2	1-3/8
310S83PF	310R83PF	8	3	4000	10-1/8	2-1/16
310S103PF	310R103PF	10	3	4100	11-1/2	2-1/4
310S123PF	310R123PF	12	3	4100	13-1/2	2-11/16



POLYURETHANE ON CAST IRON 28 PRECISION BALL BEARING

PY95A

Part Number Swivel Caster	Part Number Rigid Caster	Wheel Diameter (inch)	Tread Width (inch)	Load Capacity (lbs)	Overall Height (inch)	Swivel Lead (inch)
310S63PY	310R63PY	6	3	2040	7-1/2	1-3/8
310S83PY	310R83PY	8	3	2520	10-1/8	2-1/16
310S103PY	310R103PY	10	3	3000	11-1/2	2-1/4
310S123PY	310R123PY	12	3	3420	13-1/2	2-11/16



MEGALOAD™ AND VULKOLLAN™ WHEELS WITH PRECISION BALL BEARINGS AVAILABLE TO FIT THIS CASTER SERIES.
SIZES 6 X 3, 8 X 3, 10 X 3 & 12 X 3.

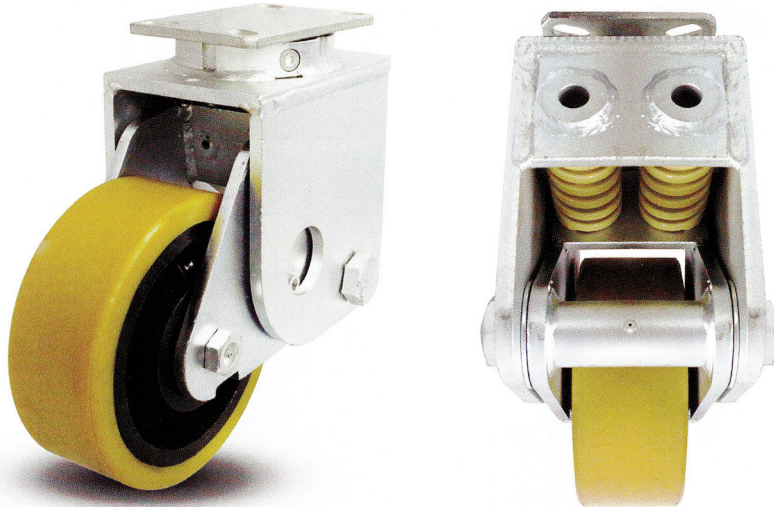

3,000 LBS. LOAD CAPACITY KINGPINLESS TYPE CASTERS

- **Load Springs:** Different load springs for each series permits wide variation in ride "softness".
- **Complete Line:** Available on all Kingpinless models.
- **Swivel Section:** Kingpinless design. Ball bearing mounted in a machined raceway.
- **Axle:** 3/4" diameter standard. Optional 1" diameter available.
- Alternate or custom caster configurations available.

MOUNTING PLATE OPTIONS

TOP PLATE: (STANDARD)

Plate Size: 4-1/2" x 6-1/4"

Bolt Holes: 2-7/16" x 4-15/16"
slotted to
3-3/8" x 5-1/4"

Bolt Size: 1/2"

Our newly designed spring loaded casters offer greater capacity and protection from damaging shock or unwanted vibration and movement. Noise levels are reduced through the dampening effect of these casters.

We offer many custom spring loaded solutions for the automotive and aviation industry.

TYPICAL APPLICATIONS

- Aviation ground support
- Aircraft tripod jacks
- Portable medical equipment
- Computer equipment
- Shock sensitive loads

NYLACRON™ WHEELS
PRECISION BALL BEARINGS
NY/MD

Part Number Swivel Caster	Part Number Rigid Caster	Wheel Diameter (inch)	Tread Width (inch)	Load Capacity (lbs)	Overall Height (inch)	Swivel Lead (inch)
S310S63NYMD	S310R63NYMD	6	3	3000	7-1/2	1-3/8
S310S83NYMD	S310R83NYMD	8	3	3000	10-1/8	2-1/16
S310S103NYMD	S310R103NYMD	10	3	3000	11-1/2	2-1/4
S310S123NYMD	S310R123NYMD	12	3	3000	13-1/2	2-11/16

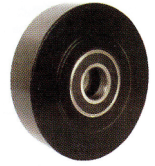

POLYURETHANE TREAD ON CAST IRON
PRECISION BALL BEARINGS
PF

Part Number Swivel Caster	Part Number Rigid Caster	Wheel Diameter (inch)	Tread Width (inch)	Load Capacity (lbs)	Overall Height (inch)	Swivel Lead (inch)
S310S63PF	S310R63PF	6	3	3000	7-1/2	1-3/8
S310S83PF	S310R83PF	8	3	3000	10-1/8	2-1/16
S310S103PF	S310R103PF	10	3	3000	11-1/2	2-1/4
S310S123PF	S310R123PF	12	3	3000	13-1/2	2-11/16



SWIVEL-EAZ™ 95A CROWN TREAD
PRECISION BALL BEARINGS
SWE/CT

FOR FLAT TREAD
 SUFFIX FT

Part Number Swivel Caster	Part Number Rigid Caster	Wheel Diameter (inch)	Tread Width (inch)	Load Capacity (lbs)	Overall Height (inch)	Swivel Lead (inch)
S310S63SWECT95	S310R63SWECT95	6	3	1100	7-1/2	1-3/8
S310S83SWECT95	S310R83SWECT95	8	3	2400	10-1/8	2-1/16
S310S103SWECT95	S310R103SWECT95	10	3	3000	11-1/2	2-1/4

• Crown tread also available in
 70A, 80A, 60D & 75D durometer

• See wheel section

