

Best Value 2C Polished Chrome Institutional Casters for Every Application

- Food Service
- Hotel & Catering Equipment
- Kitchen Equipment
- Movable Hi-tech Products
- Institutional Equipment
- Pharmaceutical
- Animal Cages
- AALAS
- Apparatus
- Instrument Equipment Carts
- Hospital
- Medical Equipment
- Laboratories
- Clean Room
- Plastic Utility Carts

POLISHED CHROME - Hardened Shim with Sealed Swivel Yoke.

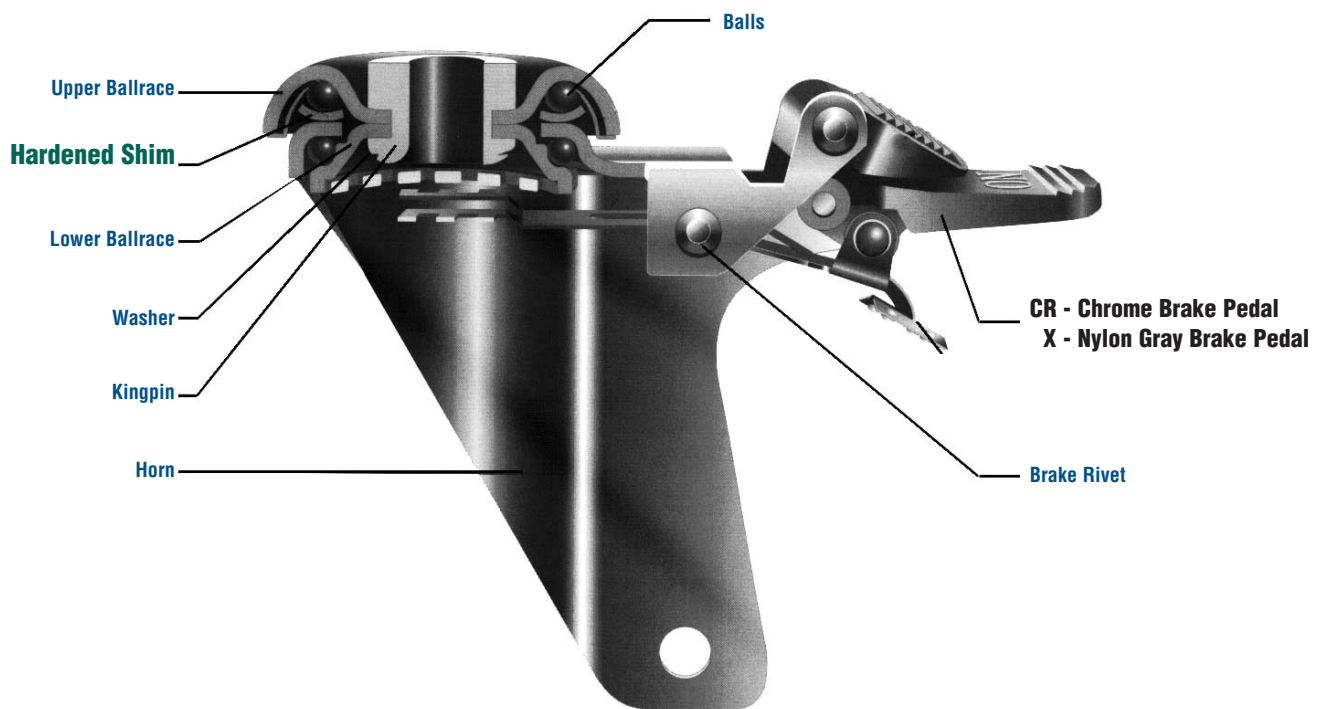

AXLE & NUT STANDARD STEEL

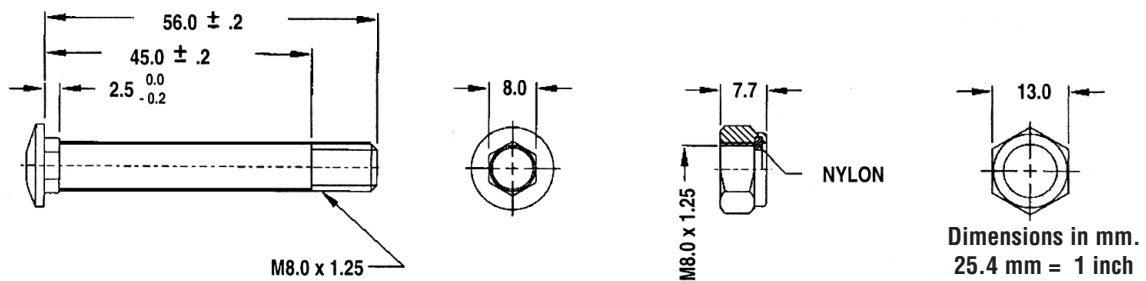

FOR ALL CASTERS & WHEELS AVAILABLE IN THIS CATEGORY
GO TO ACORN WEBSITE UNDER **CATIS DOWNLOAD**.

2

2C SERIES POLISHED CHROME TOP PLATE OPTIONS



Swivel Caster



Rigid Caster



Swivel Caster with Total Lock
Available with
nylon gray brake pedal

FEATURES

Load Capacity

Up to 300 lbs.

- Polished chrome, Pressed Steel Housing
- Pressed Steel Double Ball Race with Hardened Main Ball Raceway Shim and Hardened Steel Balls functions as Kingpinless construction to give longer life
- Metal Brake Pedal
- No Rust

SWIVEL RIG OPTIONS

- TLB** Total Lock Brake
- STG** Steel Thread Guards
- H3** Hole Casters (Swivel, Rigid or Total Lock)
- DL** Directional Lock
- X*** Nylon Gray Brake Pedal

***NYLON PEDAL: Y380XP1CR/KR3**

SWIVEL TOP PLATES (Dimensions are in mm. 25.4mm = 1in)

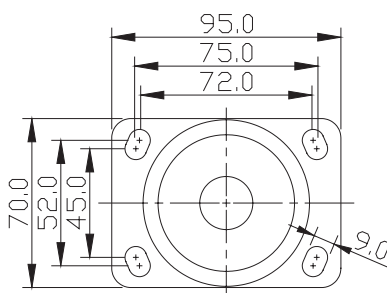

P1 Plate Standard

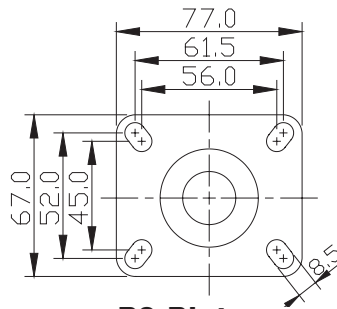

P2 Plate

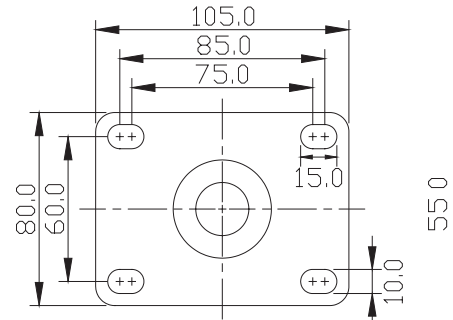

P3 Plate

RIGID TOP PLATES (Dimensions are in mm. 25.4mm = 1in)

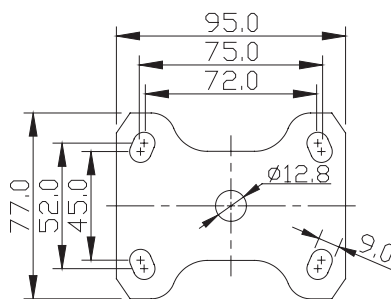

P1 Plate Standard

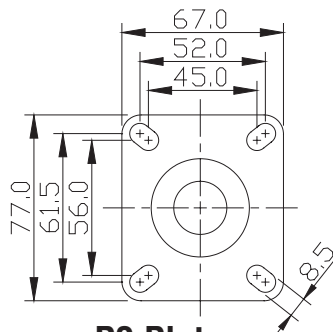

P2 Plate

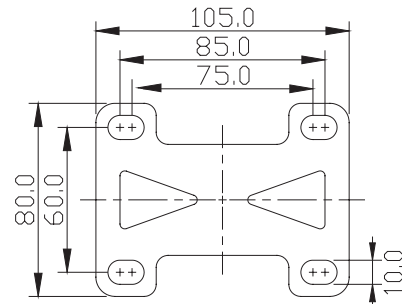

P3 Plate

2C CASTERS NOW AVAILABLE IN US TOP PLATE P51
SEE PAGE 46

SPECIFY TOP PLATE WITH P1, P2, P3 OR P51.
EXAMPLE: Y380P1CR/KR3

GRIP RING STEM OPTIONS GR

Stem Code	Stem Dimensions
GR1	3/4" diameter x 2-3/16" long
GR2	13/16" diameter x 2-3/16" long
GR3	.845" diameter x 2-3/16" long
GR4	.865" diameter x 2-3/16" long
GR5	1" diameter x 2-3/16" long
GR6	.860" square x 2-3/16" long

THREADED STEM OPTIONS TS

Stem Code	Stem Dimensions
TS1	1/2"-13 x 3/4" long
TS2	1/2"-13 x 1" long
TS3	1/2"-13 x 1-1/2" long
TS4	1/2"-20 x 3/4" long
TS5	1/2"-20 x 2-1/4" long
TS6	5/8"-11 x 1-1/4" long
TS7	5/8"-18 x 1-3/4" long
TS8	3/4"-10 x 1" long

PIPE THREAD STEM OPTIONS PS

Stem Code	Stem Dimensions
PS1	1/2" Pipe Thread (3/4" actual stem dia.)
PS2	3/4" Pipe Thread (1" actual stem dia.)
PS3	1" Pipe Thread (1-1/4" actual stem dia.)
PS4	1-1/4" Pipe Thread (1-1/2" actual stem dia.)

**OTHER SPECIAL STEMS AVAILABLE,
STANDARD OR STAINLESS STEEL.**

EXPANDING ADAPTER STEMS ES

Adapter #	Tubing ID	Adapter #	Tubing ID
ES9	3/4"	ES17B	1-3/16"
ES11	7/8"	ES19C	1-3/8"
ES13	1"	ES19A	1-1/2"
ES15	1-1/8"	ES21	1-7/8"

Rubber bushing expands inside of tubing as 3/4" nut beneath lower raceway is turned with wrench. Plastic bushing on bottom of stem provides stability for stem inside of tubing for tight, permanent fit. Threaded stem size (less adapter): 1/2" dia. x 2-3/4" long. To order, add adapter number to end of model #.

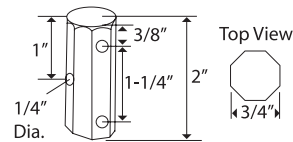
**2-PZC OCTAGON STEM OC****Standard Octagon Stem Size: OC**

3/4" octagon 2" long with 3 cross-drilled mounting holes.

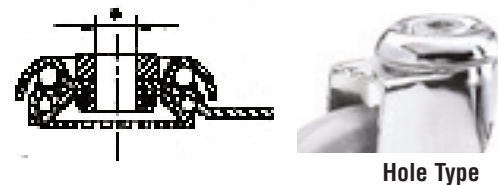
**2-PZC HOLLOW KINGPIN H3****Mounting Options: H3**

Diameter: 12.8 mm.

Bolt Size: 1/2"

SPECIFY ALL OPTIONS IN THE SUFFIX OF THE PART NUMBER.

**EXAMPLE: TS1 AT THE END
OF THE CASTER NUMBER.**

**KR
WHEELS****KRYPTONIC™ WHEELS**

- Polyether Polyurethane has excellent carrying capacity.
- Straight sided slight crown shape affords an easy-rolling quiet operation.
- Greater service life and resistance to chunking, cutting and abrasive wear.

- 100% washable, steam cleanable, and resistant to most chemicals.
- Non-marking tread.
- Durometer: 58 Shore D (+/-5).
- Stainless Steel Precision Ball Bearings.
- Temperature Range: + 250°F for up to a 1/2 hour.
- **Available in 5" hi-temp gray + 250°F for 5 to 6 hrs. add: "G" after "KR". Example: Y582P1CR/KRG5**



Part Number Swivel with Total Lock	Part Number Swivel Caster	Part Number Rigid Caster	Wheel Diameter (inch)	Tread Width (inch)	Load Capacity (lbs)	Overall Height (mm)	Swivel Radius (mm)
Y380P1CR/KR3	Y381P1CR/KR3	Y382P1CR/KR3	3	1-1/4	300	107	33
Y480P1CR/KR4	Y481P1CR/KR4	Y482P1CR/KR4	4	1-1/4	300	135	40.5
Y580P1CR/KR5	Y581P1CR/KR5	Y582P1CR/KR5	5	1-1/4	300	161	39

**ANR
WHEELS****ADVANCED RED RUBBER**

- 80 (+5) Shore (A).
- Unique soft tread wheel handles the heat for autoclave applications.
- Roll quiet and smooth ride.

- Recommended for use in hospitals, laboratories and cleanrooms.
- Corrosion resistant thermoplastics.
- Resilient tread material rejects floor debris.
- Stainless Steel Precision Ball Bearings.
- Temp Range: -190°F to +300°F.



Part Number Swivel with Total Lock	Part Number Swivel Caster	Part Number Rigid Caster	Wheel Diameter (inch)	Tread Width (inch)	Load Capacity (lbs)	Overall Height (mm)	Swivel Radius (mm)
Y480P1CR/ANR4	Y481P1CR/ANR4	Y482P1CR/ANR4	4	1-1/4	175	135	40.5
Y580P1CR/ANR5	Y581P1CR/ANR5	Y582P1CR/ANR5	5	1-1/4	220	161	39
Y680P1CR/ANR6	Y681P1CR/ANR6	Y682P1CR/ANR6	6	1-1/4	245	167	45

**NY/MC
WHEELS****NYLACRON™**

- Precision Machined from cast polyamide hardness 112-120 Rockwell R.
- Ultimate choice for extremely high load applications to replace metallic wheels.
- Offer very high abrasion resistance and very low rolling resistance under extreme loads.

- Resistant to salt, grease, alcohol and mild acids - can be used in corrosive applications with appropriate bearings.
- Precision Ball Bearings.
- Temperature Range: -40°F to +270°F.
- **Available in black MY/MD.**



Part Number Swivel with Total Lock	Part Number Directional Lock	Part Number Swivel Caster	Wheel Diameter (inch)	Tread Width (inch)	Load Capacity (lbs)	Overall Height (mm)	Swivel Radius (mm)
Y380P1CR/NYMC	Y381P1CR/NYMC	Y382P1CR/NYMC	3	1-1/4	220	107	33
Y480P1CR/NYMC	Y481P1CR/NYMC	Y482P1CR/NYMC	4	1-1/4	220	135	40.5
Y580P1CR/NYMC	Y581P1CR/NYMC	Y582P1CR/NYMC	5	1-1/4	220	161	39

**TPR
WHEELS****THERMOPLASTIC GRAY TREAD
RUBBER PLASTIC HUB.**

- 70 (+/-5) Durometer Shore (A).
- Recommended for clean environments.

- Resists most solvents, oil, grease, and water.
- Non-marking.
- Smooth rolling and quiet.
- Precision Ball Bearings.
- Temp Range: -45°F to +180°F.



Part Number Swivel with Total Lock	Part Number Swivel Caster	Part Number Rigid Caster	Wheel Diameter (inch)	Tread Width (inch)	Load Capacity (lbs)	Overall Height (mm)	Swivel Radius (mm)
Y380P1CR/W312	Y381P1CR/W312	Y382P1CR/W312	3	1-1/4	130	107	33
Y480P1CR/W412	Y481P1CR/W412	Y482P1CR/W412	4	1-1/4	175	135	40.5
Y580P1CR/W512	Y581P1CR/W512	Y582P1CR/W512	5	1-1/4	220	161	39

**PRB
WHEELS****ELASTIC RUBBER**

- Plastic hub material.
- Plastic 3" & Steel 4" & 5" thread guards.
- Gray color elastic rubber tire material.

- Precision Ball Bearings.
- Short-term temperature range: -40°/80°C.



Part Number Swivel with Total Lock	Part Number Swivel Caster	Part Number Rigid Caster	Wheel Diameter (inch)	Tread Width (inch)	Load Capacity (lbs)	Overall Height (mm)
Y380P1CR/W324	Y381P1CR/W324	Y382P1CR/W324	3	1-1/4	110	107
Y480P1CR/W424	Y481P1CR/W424	Y482P1CR/W424	4	1-1/4	175	135
Y580P1CR/W524	Y581P1CR/W524	Y582P1CR/W524	5	1-1/4	220	161
Y680P1CR/W624	Y681P1CR/W624	Y682P1CR/W624	6	1-1/4	220	190

**SRB
WHEELS****ELASTIC RUBBER**

- Pressed steel hub material.
- Steel thread guards.
- Gray color elastic rubber tire material.

- Precision Ball Bearings.
- Short-term temperature range: -40°/80°C.



Part Number Swivel with Total Lock	Part Number Swivel Caster	Part Number Rigid Caster	Wheel Diameter (inch)	Tread Width (inch)	Load Capacity (lbs)	Overall Height (mm)
Y480P1CR/W423	Y481P1CR/W423	Y482P1CR/W423	4	1-1/4	175	135
Y580P1CR/W523	Y581P1CR/W523	Y582P1CR/W523	5	1-1/4	220	161
Y680P1CR/W623	Y681P1CR/W623	Y682P1CR/W623	6	1-1/4	220	190

**PM
WHEELS****NYLACRON™**

- Steel thread guards.
- White color.

- Roller Bearings.
- Short-term temperature range: -30°/+120°C.



Part Number Swivel with Total Lock	Part Number Swivel Caster	Part Number Rigid Caster	Wheel Diameter (inch)	Tread Width (inch)	Load Capacity (lbs)	Overall Height (mm)
Y380P1CR/W309RX	Y381P1CR/W309RX	Y382P1CR/W309RX	3	1-1/4	110	107
Y480P1CR/W409RX	Y481P1CR/W409RX	Y482P1CR/W409RX	4	1-1/4	175	135
Y580P1CR/W509RX	Y581P1CR/W509RX	Y582P1CR/W509RX	5	1-1/4	220	161

2

2C POLISHED CHROME FINISH PLATE CASTERS

TPR/AS WHEELS

ANTI-STATIC PLASTIC HUB, GRAY COLOR CONDUCTIVE THERMOPLASTIC RUBBER TREAD

- 70 (+/-5) Durometer Shore (A).
- Anti-static plastic hub.
- Non-marking.
- Easy rolling, impact resistant and shock absorbing.
- Precision Ball Bearings.
- Temp Range: -40°F to +120°F.



Part Number Swivel with Total Lock	Part Number Swivel Caster	Part Number Rigid Caster	Wheel Diameter (inch)	Tread Width (inch)	Load Capacity (lbs)	Overall Height (mm)	Swivel Radius (mm)
Y480P1CR/W403AS	Y481P1CR/W403AS	Y482P1CR/W403AS	4	1-1/4	175	135	40.5
Y580P1CR/W503AS	Y581P1CR/W503AS	Y582P1CR/W503AS	5	1-1/4	220	161	39
Y680P1CR/W603UAS	Y681P1CR/W603UAS	Y682P1CR/W603UAS	6	1-1/4	240	190	50

TPU WHEELS

PLASTIC HUB, GRAY COLOR POLYURETANE TREAD

- 95 (+/-5) Durometer Shore (A).
- Plastic hub.
- Non-marking.
- High impact and abrasion resistant.
- Precision Ball Bearings.
- Temp Range: -40°F to +180°F.



Part Number Swivel with Total Lock	Part Number Swivel Caster	Part Number Rigid Caster	Wheel Diameter (inch)	Tread Width (inch)	Load Capacity (lbs)	Overall Height (mm)	Swivel Radius (mm)
Y380P1CR/W300	Y381P1CR/W300	Y382P1CR/W300	3	1-1/4	110	107	40.5
Y480P1CR/W400	Y481P1CR/W400	Y482P1CR/W400	4	1-1/4	175	135	39
Y580P1CR/W500	Y581P1CR/W500	Y582P1CR/W500	5	1-1/4	220	161	45

*steel tread guard

P1, P2, P3 for Swivel Plate Sizes
TL for Total Lock to Swivel Caster

P4, P5, or P6 for Rigid Plate Sizes
DL for Directional Lock

All wheels with precision ball bearings
H3 for Hole Caster

NOTE: All load ratings are for manual operation.

OTHER TYPE 1 1/4" WHEELS AVAILABLE FOR THIS SERIES.

NYLACRON™ MD (NY/MD), NYLACRON™ MONOCAST (NY/MC), SOLID NYLON (PM), HIGH TEMP WHEELS AVAILABLE. SEE WHEEL SECTION.

**KR
WHEELS****KRYPTONIC™ WHEELS**

- Polyether Polyurethane has excellent carrying capacity.
- Straight sided slight crown shape affords an easy-rolling quiet operation.
- Greater service life and resistance to chunking, cutting and abrasive wear.

- 100% washable, steam cleanable, and resistant to most chemicals.
- Non-marking tread.
- Durometer: 58 Shore D (+/-5).
- Stainless Steel Precision Ball Bearings.
- Temperature Range: + 250°F for up to a 1/2 hour.
- Available in 5" hi-temp gray + 250°F for 5 to 6 hrs. add: "G" after "KR". Example: Y582P1CR/KRG5



Part Number Swivel with Total Lock	Part Number Swivel Caster	Wheel Diameter (inch)	Tread Width (inch)	Load Capacity (lbs)	Overall Height (mm)	Swivel Radius (mm)
Y380P1H3CR/KR3	Y381P1H3CR/KR3	3	1-1/4	300	107	33
Y480P1H3CR/KR4	Y481P1H3CR/KR3	4	1-1/4	300	135	40.5
Y580P1H3CR/KR5	Y581P1H3CR/KR3	5	1-1/4	300	161	39

**ANR
WHEELS****ADVANCED RED RUBBER**

- 80 (+/-5) Shore (A).
- Unique soft tread wheel handles the heat for autoclave applications.
- Roll quiet and smooth ride.

- Recommended for use in hospitals, laboratories and cleanrooms.
- Corrosion resistant thermoplastics.
- Resilient tread material rejects floor debris.
- Stainless Steel Precision Ball Bearings.
- Temp Range: -190°F to +300°F.



Part Number Swivel with Total Lock	Part Number Swivel Caster	Wheel Diameter (inch)	Tread Width (inch)	Load Capacity (lbs)	Overall Height (mm)	Swivel Radius (mm)
Y480P1H3CR/ANR4	Y481P1H3CR/ANR4	4	1-1/4	175	135	40.5
Y580P1H3CR/ANR5	Y481P1H3CR/ANR5	5	1-1/4	220	161	39
Y680P1H3CR/ANR6	Y481P1H3CR/ANR6	6	1-1/4	245	167	45

**RT
WHEELS****RETORT**

- 75 Durometer Shore (D).
- Designed to withstand the rigors of high temperature.

- Oversized bore ID ensures smooth movement.
- Moderate crown/White finish.
- Precision Ball Bearings.
- Temp Range: -20°F to +290°F.



Part Number Swivel with Total Lock	Part Number Swivel Caster	Wheel Diameter (inch)	Tread Width (inch)	Load Capacity (lbs)	Overall Height (mm)	Swivel Radius (mm)
Y380P1H3CR/RT3H3	Y381P1H3CR/RT3H3	3	1-1/4	130	107	33
Y480P1H3CR/RT4H3	Y481P1H3CR/RT4H3	4	1-1/4	175	135	40.5
Y580P1H3CR/RT5H3	Y581P1H3CR/RT5H3	5	1-1/4	220	161	39

**TPR
WHEELS****THERMOPLASTIC GRAY TREAD RUBBER PLASTIC HUB.**

- 70 (+/-5) Durometer Shore (A).
- Recommended for clean environments.
- Resists most solvents, oil, grease, and water.

- Non-marking.
- Smooth rolling and quiet.
- Precision Ball Bearings.
- Temp Range: -45°F to +180°F.



Part Number Swivel with Total Lock	Part Number Swivel Caster	Wheel Diameter (inch)	Tread Width (inch)	Load Capacity (lbs)	Overall Height (mm)	Swivel Radius (mm)
Y380P1H3CR/W312	Y381P1H3CR/W312	3	1-1/4	130	107	33
Y480P1H3CR/W412	Y481P1H3CR/W412	4	1-1/4	175	135	40.5
Y580P1H3CR/W512	Y581P1H3CR/W512	5	1-1/4	220	161	39

2

2C POLISHED CHROME FINISH H3 HOLE CASTERS

PRB WHEELS

ELASTIC RUBBER

- Plastic hub material.
- Plastic 3" & Steel 4" & 5" thread guards.
- Gray color elastic rubber tire material.
- Precision Ball Bearings.
- Short-term temperature range: -40°/80°C.



Part Number Swivel with Total Lock	Part Number Swivel Caster	Wheel Diameter (inch)	Tread Width (inch)	Load Capacity (lbs)	Overall Height (mm)
Y380P1H3CR/W324	Y381P1H3CR/W324	3	1-1/4	110	107
Y480P1H3CR/W424	Y481P1H3CR/W424	4	1-1/4	175	135
Y580P1H3CR/W524	Y581P1H3CR/W524	5	1-1/4	220	161

SRB WHEELS

ELASTIC RUBBER

- Pressed steel hub material.
- Steel thread guards.
- Gray color elastic rubber tire material.
- Precision Ball Bearings.
- Short-term temperature range: -40°/80°C.



Part Number Swivel with Total Lock	Part Number Swivel Caster	Wheel Diameter (inch)	Tread Width (inch)	Load Capacity (lbs)	Overall Height (mm)
Y480P1H3CR/W423	Y481P1H3CR/W423	4	1-1/4	175	135
Y580P1H3CR/W523	Y581P1H3CR/W523	5	1-1/4	220	161
Y680P1H3CR/W623	Y681P1H3CR/W623	6	1-1/4	220	190

PM WHEELS

NYLACRON™

- Steel thread guards.
- White color.
- Roller Bearings.
- Short-term temperature range: -30°/+120°C.
- Available in black MY/MD.



Part Number Swivel with Total Lock	Part Number Swivel Caster	Wheel Diameter (inch)	Tread Width (inch)	Load Capacity (lbs)	Overall Height (mm)
Y380P1H3CR/W309RX	Y381P1H3CR/W309RX	3	1-1/4	110	107
Y480P1H3CR/W409RX	Y481P1H3CR/W409RX	4	1-1/4	175	135
Y580P1H3CR/W509RX	Y581P1H3CR/W509RX	5	1-1/4	220	161

TPR/AS
WHEELS

ANTI-STATIC PLASTIC HUB,
GRAY COLOR CONDUCTIVE THERMOPLASTIC
RUBBER TREAD

- 70 (+/-5) Durometer Shore (A).
- Anti-static plastic hub.

- Non-marking.
- Easy rolling, impact resistant and shock absorbing.
- Precision Ball Bearings.
- Temp Range: -40°F to +120°F.



Part Number Swivel with Total Lock	Part Number Swivel Caster	Wheel Diameter (inch)	Tread Width (inch)	Load Capacity (lbs)	Overall Height (mm)	Swivel Radius (mm)
Y480P1H3CR/W403AS	Y481P1H3CR/W403AS	4	1-1/4	175	135	40.5
Y580P1H3CR/W503AS	Y581P1H3CR/W503AS	5	1-1/4	220	161	39
Y680P1H3CR/W603UAS	Y681P1H3CR/W603UAS	6	1-1/4	240	189.5	50

TPU
WHEELS

PLASTIC HUB, GRAY COLOR
POLYURETANE TREAD

- 95 (+/-5) Durometer Shore (A).
- Plastic hub.

- Non-marking.
- High impact and abrasion resistant.
- Temp Range: -40°F to +180°F.



Part Number Swivel with Total Lock	Part Number Swivel Caster	Wheel Diameter (inch)	Tread Width (inch)	Load Capacity (lbs)	Overall Height (mm)	Swivel Radius (mm)
Y380P1H3CR/W300	Y381P1H3CR/W300	3	1-1/4	110	107	40.5
Y480P1H3CR/W400	Y481P1H3CR/W400	4	1-1/4	175	135	39
Y580P1H3CR/W500	Y581P1H3CR/W500	5	1-1/4	220	161	45

*steel tread guard

*P1, P2, P3 for Swivel Plate Sizes

P4, P5, or P6 for Rigid Plate Sizes

All wheels with precision ball bearings

**TL for Total Lock to Swivel Caster

DL for Directional Lock

H3 for Hole Caster

NOTE: All load ratings are for manual operation.

OTHER TYPE 1 1/4" WHEELS AVAILABLE FOR THIS SERIES: IE, ELASTIC RUBBER: WHITE NYLON

NYLACRON™ MD (NY/MD), NYLACRON™ MONOCAST (NY/MC), HIGH TEMP WHEELS AVAILABLE. SEE WHEEL SECTION.