

1 1DW SERIES DUAL WHEEL CASTERS

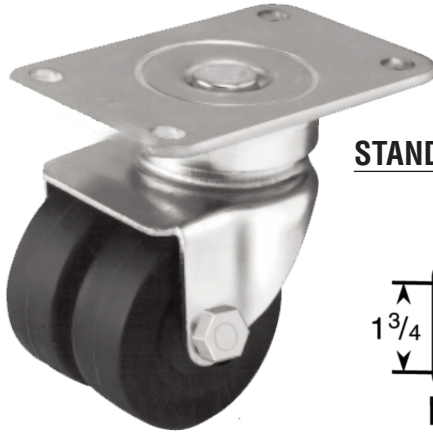

STANDARD TOP PLATE 20

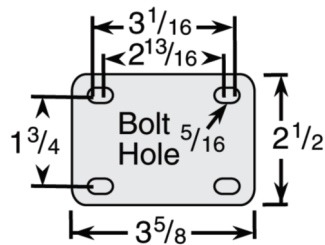

**ADDITIONAL
TOP PLATES
AVAILABLE**

APPLICATIONS

- Laboratory Equipment
- Medical Equipment
- IV Stands
- Computer Stands
- Electronic Enclosures
- Copy Machines
- Disk Storage Devices
- Display Racks
- Airport Terminal Stands

FOUR SIDED DOUBLE BALL BEARING RACEWAY 30 SERIES

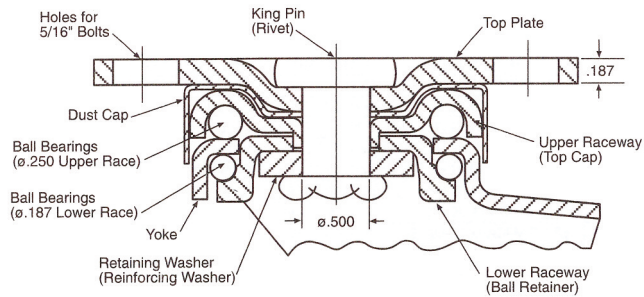

400 LBS. LOAD CAPACITY TYPE CASTERS

- Four-sided, double ball raceway
- Heat treated moving parts
- Raceway dust cap
- Low overall height
- Thumb style wheel brake
- Conductive or static dissipative wheels
- Gray, non-marking wheels
- Standard bright zinc or black oxide finishes
- Maintenance free swivel bearings

1 1DW SERIES DUAL WHEEL CASTERS

SPECIFICATIONS

Diameter	Tread Width	Load Capacity	Wheel Description	Bearing	Swivel Part Number	Rigid Part Number	Approx. Weight (lbs)	Overall Height (inch)	Swivel Radius (inch)
2	7/8	250	Round Donut/Neoprene	Ball	32-20-XDN-RD	32-20-XRDN-RD	2	3-1/4	2-1/4
2	7/8	250	Neoprene Rubber	Ball	32-20-XDN	32-20-XRDN	2	3-1/4	2-1/4
2	7/8	250	Hard Rubber	Ball	32-20-XH	32-20-XRH	2	3-1/4	2-1/4
2	7/8	300	Hi-Cap Neoprene	Ball	32-20-XKN	32-20-XRKN	2	3-1/4	2-1/4
2	7/8	400	Advanced Elastomer	Ball	32-20-XAE	32-20-XRAE	2	3-1/4	2-1/4
2	7/8	400	Polyolefin	Ball	32-20-XPO	32-20-XRPO	2	3-1/4	2-1/4
2-1/2	7/8	250	Neoprene Rubber	Ball	32-1/2-20-XDN	32-1/2-20-XRDN	2-1/2	3-3/4	2-5/8
2-1/2	7/8	330	Hard Rubber	Ball	32-1/2-20-XH	32-1/2-20-XRH	2-1/2	3-3/4	2-5/8
2-1/2	7/8	350	Hi-Cap Neoprene	Ball	32-1/2-20-XKN	32-1/2-20-XRKN	2-1/2	3-3/4	2-5/8
2-1/2	7/8	400	Polyurethane/Cast Iron Hub	Ball	32-1/2-20-XADI-M-CI	32-1/2-20-XRADI-M-CI	3	3-3/4	2-5/8
2-1/2	7/8	400	Advanced Elastomer	Ball	32-1/2-20-XAE	32-1/2-20-XRAE	2-1/2	3-3/4	2-5/8

* Special Order/Minimum Quantity

STEM SIZES AVAILABLE

“O” GRIP RING STEM TABLE

Dimension D	Dimension L	Stem Number
1/2”*	1-1/2”	O-12-112
5/8”	2”	O-58-2
3/4”*	2”	O-34-2
7/8”	2”	O-78-2
1”	2-1/2”	O-1-212

Other stem sizes and dimensions available.

* Special Order/Minimum Quantity

“L” TREADED STEM TABLE

Dimension T	Dimension L	Stem Number
1/2”-13	1-1/2”	L-1213-112
1/2”-13	2”	L-1213-2
5/8”-11	2”	L-5811-2
5/8”-11	2-1/2”	L-5811-212
3/4”-10	1-1/2”	L-3410-112
3/4”-10	2”	L-3410-2
3/4”-10	2-1/2”	L-3410-212

Other stem sizes and dimensions available.

* Special Order/Minimum Quantity