

# STAGE/SCENE SHIFTING CASTERS

## STAGE/SCENE SHIFTING CASTERS

Primarily used in the theatrical and movie making industries for moving scenery, props and stage equipment. StageMaster incorporates three swiveling casters attached to a heavy-duty swiveling platform base that easily mounts to the item to be moved. The swiveling action of the casters combined with the swiveling action of the platform base allows the operator to easily maneuver heavy, awkward devices in tight quarters with relative ease.

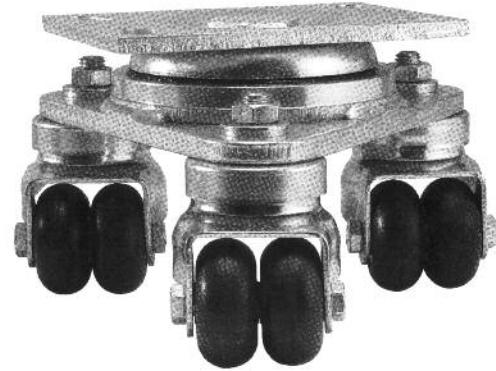

**Scene Shifting Dollies**  
Kingpinless Swivel Section & Nylacron™ Wheels  
with Precision Bearings Recommended

## DESIGN CHARACTERISTICS

**Single or Dual Wheel Caster Design:** Dual wheel caster version with 2" or 2-1/2" diameter wheels. Single caster version with 2-1/2" or 3" diameter wheels.

**Four-Sided Double Ball Raceway:** Hardened steel ball bearings in the load bearing and secondary thrust bearing through the swivel raceway "on all four sides." This protects the central kingpin from shock loading for free swiveling under heavy loads.

**Heat Treated Moving Parts:** All moving parts are heat treated to a precise molecular depth and Rockwell hardness. This extends StageMaster life under rugged conditions and shock loads.

**Raceway Dust Caps on Casters / Underbody Seal on Platform Base:** Dust caps and underbody seals protect raceways from contamination by dust, dirt, moisture and other debris.

**Thread Guards:** Single-Wheel version only. Keeps unwanted materials out of wheel bearings thus increasing the life of the StageMaster assembly.

## SWIVEL RIG OPTIONS

- Increased Capacities, Diameter and Sizes for any load capacity with Nylacron™ Wheels.
- Kingpinless swivel section and Kingpinless casters recommended for heavy duty applications.
- Black Oxide Finish. Other finishes available, consult Acorn™.
- Wheel Brakes (Consult Acorn™)
- Wheel Materials & Diameters.

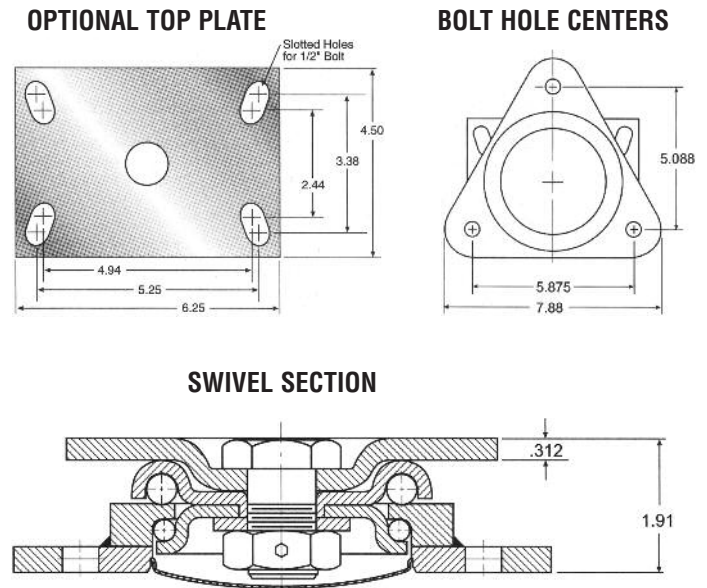

## CASTER SPECIFICATIONS/NYLACRON™ WHEELS

Dia. (inch)	Width (inch)	Cap. (lb)	OAH (inch)	Wheels Per Caster	Wt. (lb)	Swivel Part Number Add B, P, PL, R or T*
2	7/8	1200	5	2	14	SMNYP*0278S
2-1/2	1-1/4	1200	5-1/2	1	13	SMNYP*2512S
3	2	1800	6-1/4	1	20	SMNYP*0320S

\*Add "B" for Ball Bearing, "P" for Precision Bearing, "PL" for Plain Bearing, "R" for Roller Bearing or "D" for Delrin Bearing

**CAD DRAWINGS FOR STAGE/SCENE SHIFTING CASTERS & DOLLIES AVAILABLE**

**CUSTOM DOLLIES AVAILABLE**