

SECTION III

LEVEL - RITE® MOUNTS

Level-Rite® Leveling Mounts	26-27
Level-Rite® Installation Procedures	28-29
Level-Rite® Machinery Mounts for Bridgeport™ Machines	30
Hollow Base Mounting Kits	31
Tri-Wedge 8000 Mounts	32-33
Machinery Mount Application Guide	34-37
Machinery Installation Systems	37-A
Machinery Installation Procedures - U Mounts	37-B

MODEL	MAX LOAD	A	B	C	D	E
LR200	200	2 1/8"	3 1/2"	3 1/2"	3 1/2"	3 1/2"
LR300	300	2 1/8"	3 1/2"	3 1/2"	3 1/2"	3 1/2"
LR400	400	2 1/8"	3 1/2"	3 1/2"	3 1/2"	3 1/2"
LR500	500	2 1/8"	3 1/2"	3 1/2"	3 1/2"	3 1/2"
LR600	600	2 1/8"	3 1/2"	3 1/2"	3 1/2"	3 1/2"
LR700	700	2 1/8"	3 1/2"	3 1/2"	3 1/2"	3 1/2"
LR800	800	2 1/8"	3 1/2"	3 1/2"	3 1/2"	3 1/2"
LR900	900	2 1/8"	3 1/2"	3 1/2"	3 1/2"	3 1/2"
LR1000	1000	2 1/8"	3 1/2"	3 1/2"	3 1/2"	3 1/2"
LR1200	1200	2 1/8"	3 1/2"	3 1/2"	3 1/2"	3 1/2"



LR-200 AND LR-500 SERIES

The LR-200 and LR-500 SERIES are designed for lighter equipment applications. The LR-200 is for loadings up to 250 pounds per mount and the LR-500 is designed for loadings up to 500 pounds. Both LR models have solid steel bases and built-in leveling screws.

LR-750 THRU LR-1200 SERIES

The LR thru LR-1200 are of extra heavy-duty construction in a compact design intended for general purpose use. They also work well with machines that generate high impact loads and unusually high horizontal loads. Machine loads are borne by the tough cast iron mount housings. For more extreme lateral load cases, the standard 1" thick isolation pad bonded with a high coefficient of friction surface is used to prevent "walking". All LR Series mounts can compensate for pitched floors.

LEVEL-RITE® LEVELING MOUNTS

EXTRA RUGGED DESIGN SIMPLIFIES LEVELING DAMPENS VIBRATION AND NOISE

LEVEL-RITE® MOUNTS are self-contained leveling mounts with RED-LINE™ ANCHOR PADS. They combine vibration and noise control with reliable leveling which eliminates the need for lagging or adhesives. LEVEL-RITE® MOUNTS conform to OSHA requirements.

HOW TO SPECIFY LEVEL-RITE® MOUNTS

Mount loadings are expressed in pounds shown in the chart below. To determine the approximate load applied by a particular machine, divide the total weight by the number of mounting points. Note that in certain cases, where weight distribution may load one or more mounts significantly more than others, special consideration is required. When machinery generating high impact is being mounted, reduce the mount rating by 25% to assure maximum performance.

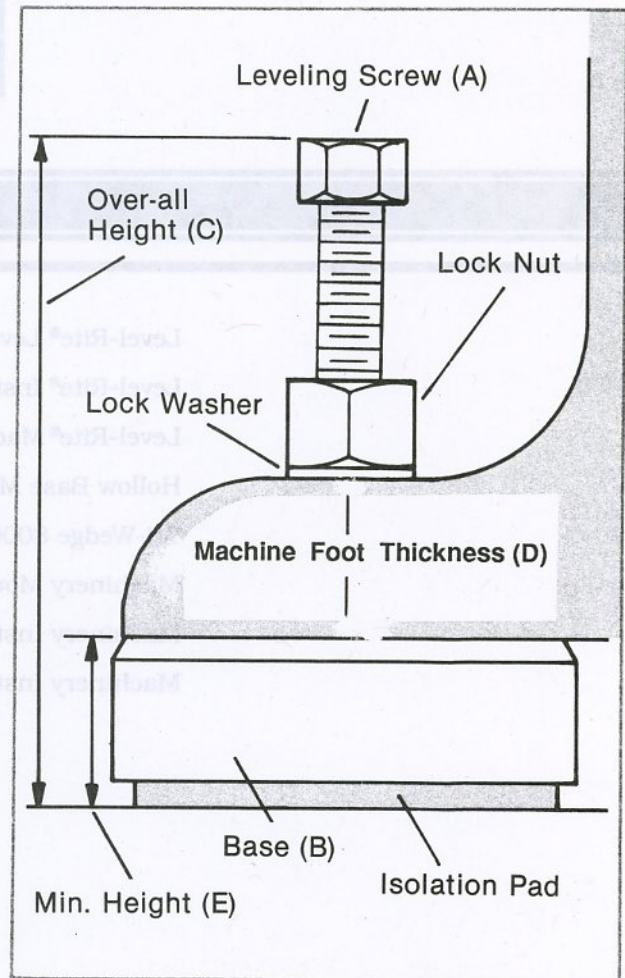
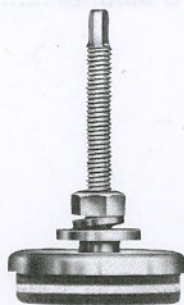

LR-200 AND LR-500 SERIES

The LR-200 and LR-500 SERIES are designed for lighter equipment applications. The LR-200 is for loadings up to 250 pounds per mount and the LR-500 is designed for loadings up to 500 pounds. Both LR models have solid steel bases and built-in leveling screws.

LR-750 THRU LR-12000 SERIES

The LR thru LR-12000 are of extra heavy-duty construction in a compact design intended for general purpose use. They also work well with machines that generate high impact loads and unusually high horizontal loads. Machine loads are borne by the tough cast iron mount housings. For more extreme lateral load cases, the standard 1" thick isolation pad bonded with a high coefficient-of-friction surface is used to prevent "walking". All LR Series mounts can compensate for pitched floors.

SPECIFICATIONS

MODEL	MAX LOAD	A	B	C	D*	E
LR200	250	5/16-18	2 7/8 Dia.	3 1/2	2 1/2	9/16
LR500	500	3/8-16	3 1/2 Dia.	4 1/2	2 3/4	5/8
LR750	750	1/2-13	3 1/2x5 1/2	7	2 7/8	1 3/4
LR1200	1,200	5/8-11	3 1/2x5 1/2	7	2 7/8	1 3/4
LR2000	2,000	5/8-11	3 1/2x5 1/2	7	2 7/8	1 3/4
LR3000	3,000	3/4-10	5x8	8 1/2	2 7/8	2
LR5000	5,000	3/4-10	5x8	8 1/2	2 7/8	2
LR7500	7,500	1-8	5x8	8 1/2	2 7/8	2
LR12000	12,000	1-8	5x8	8 1/2	2 7/8	2

*LR Series has 1/2" adjustment for leveling machine.

Special length leveling screws available for non-standard applications.

LEVEL-RITE® LEVELING MOUNTS

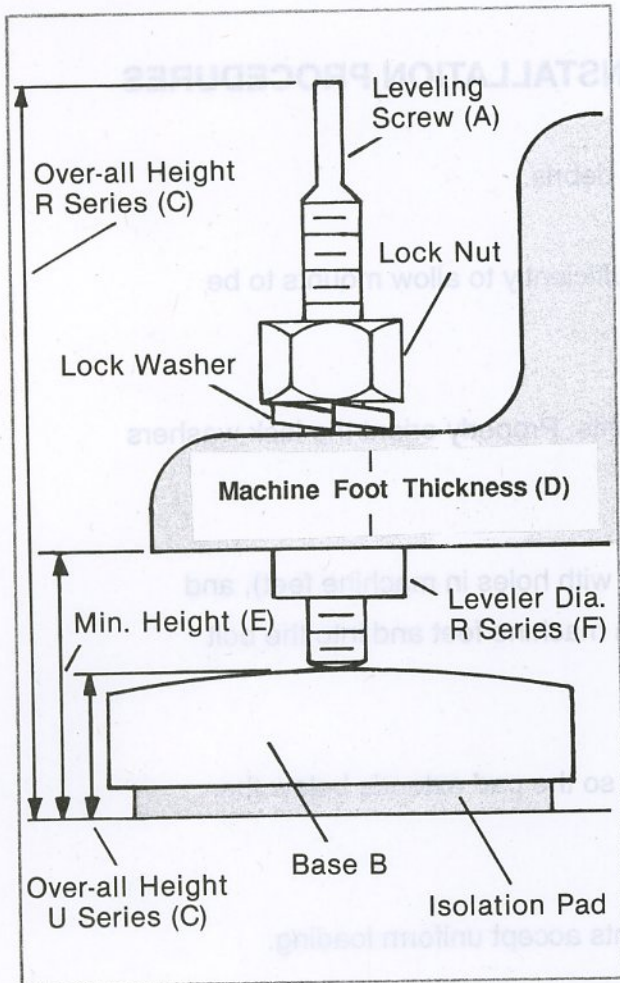

SPECIFICATIONS

MODEL	MAX LOAD	A	B	C	D	E	F
R5	500	1/2-13	3x3	7	2 3/4	1 3/4	1 3/4
R9	900	1/2-13	3x3	7	2 3/4	1 3/4	1 3/4
R16	1,600	5/8-11	4x4	7	2 3/4	1 3/4	1 3/4
R27	2,700	1/2-13	3x3	7	2 3/4	1 3/4	1 3/4
R36	3,600	1-8	6x6	7 1/2	2 3/4	2 5/8	2 1/4
R48	4,800	5/8-11	4x4	7	2 3/4	1 3/4	1 3/4
R100	10,800	1-8	6x6	7 1/2	2 3/4	2 5/8	2 1/4
U5	500	—	3x3	1	—	—	—
U9	900	—	3x3	1	—	—	—
U16	1,600	—	4x4	1	—	—	—
U27	2,700	—	3x3	1	—	—	—
U36	3,600	—	6x6	1 1/2	—	—	—
U48	4,800	—	4x4	1	—	—	—
U100	10,800	—	6x6	1 1/2	—	—	—



RED-LINE™ ANCHOR PADS USED ON LEVEL-RITE® MOUNTS

Engineered felt is used to reduce vibration transmission and noise. The nylon/acrylic bonding on the pad provides an extremely high coefficient-of-friction between the pad and the floor surface to provide maximum protection against machine movement without physical anchoring. Pads are unaffected by oils and solutions used in manufacturing plants.

R SERIES

FOR ALL TYPES OF MACHINERY



The UNISORB® R SERIES is a self-contained leveling mount with a 1/2" thick pad for all types of machinery. Rugged cast iron and anodized steel construction with a free-floating leveling screw offer vertical adjustments of up to 2". They will also compensate for pitched or uneven floors.

U SERIES

FOR PRECISION EQUIPMENT

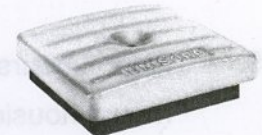

The U SERIES self-contained mounts with RED-LINE™ ANCHOR PADS are designed to accept machinery leveling screws and are supplied without leveling accessories. Their rugged heavy-duty construction is designed for precision and finishing equipment.

LEVEL-RITE® INSTALLATION PROCEDURES

LEVEL-RITE MACHINERY MOUNTS INSTALLATION PROCEDURES

1. Clean floor removing all oil, grease and debris.
2. Bring machine into location and raise sufficiently to allow mounts to be positioned under the mounting feet.
3. Remove the leveling bolts from the mounts. Properly orient the lock washers and hex nuts on the bolts.
4. Position mounts (with bolt holes aligned with holes in machine feet), and insert leveling bolts through bolt holes in machine feet and into the bolt holes in the mounts.
5. Adjust each mount with the leveling bolt so the pad extends below the mount housing approximately 1/4".
6. Lower machine onto mounts so all mounts accept uniform loading.
7. After 20 minutes locate the mount housing closest to the floor and elevate it 1/8" to 1/4" off the floor. Level the machine by adjusting the other mounts using the first mount as the point of reference. Maximum amount of pad showing below housing should not exceed 5/8".
8. Tighten nuts and lock washers, thus securing machine feet to mounts.
9. After 2 hours and 24 hours of operation recheck the lowest mount to insure mount housing is not in contact with the floor.

LEVEL-RITE® INSTALLATION PROCEDURES

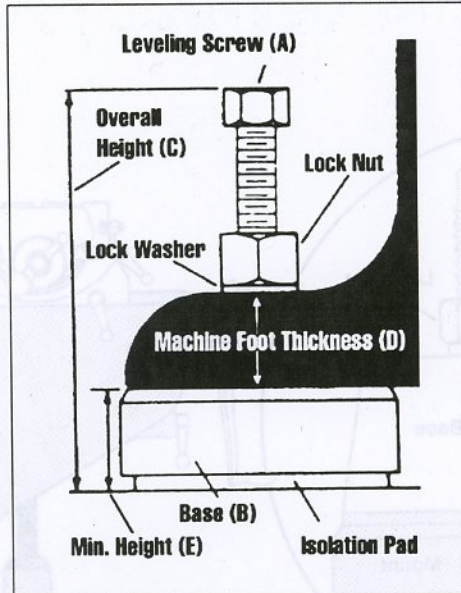

MODEL	MAX LOAD	A	B	C	D*	E
LR200	250	5/16 - 18	2 1/8 Dia.	3 1/2	2 1/2	9/16
LR500	500	3/8 - 16	3 1/2 Dia.	4 1/2	2 3/4	5/8
LR750	750	1/2 - 13	3 1/2 x 5 1/2	7	2 7/8	1 3/4
LR1200	1200	5/8 - 11	3 1/2 x 5 1/2	7	2 7/8	1 3/4
LR2000	2000	5/8 - 11	3 1/2 x 5 1/2	7	2 7/8	1 3/4
LR3000	3000	3/4 - 10	5 x 8	8 1/2	2 7/8	2
LR5000	5000	3/4 - 10	5 x 8	8 1/2	2 7/8	2
LR7500	7500	1 - 8	5 x 8	8 1/2	2 7/8	2
LR12000	12,000	1 - 8	5 x 8	8 1/2	2 7/8	2

*LR Series has 1/2" adjustment for leveling machine.

LEVEL-RITE® MACHINERY MOUNTS - FOR BRIDGEPORT™ MACHINES

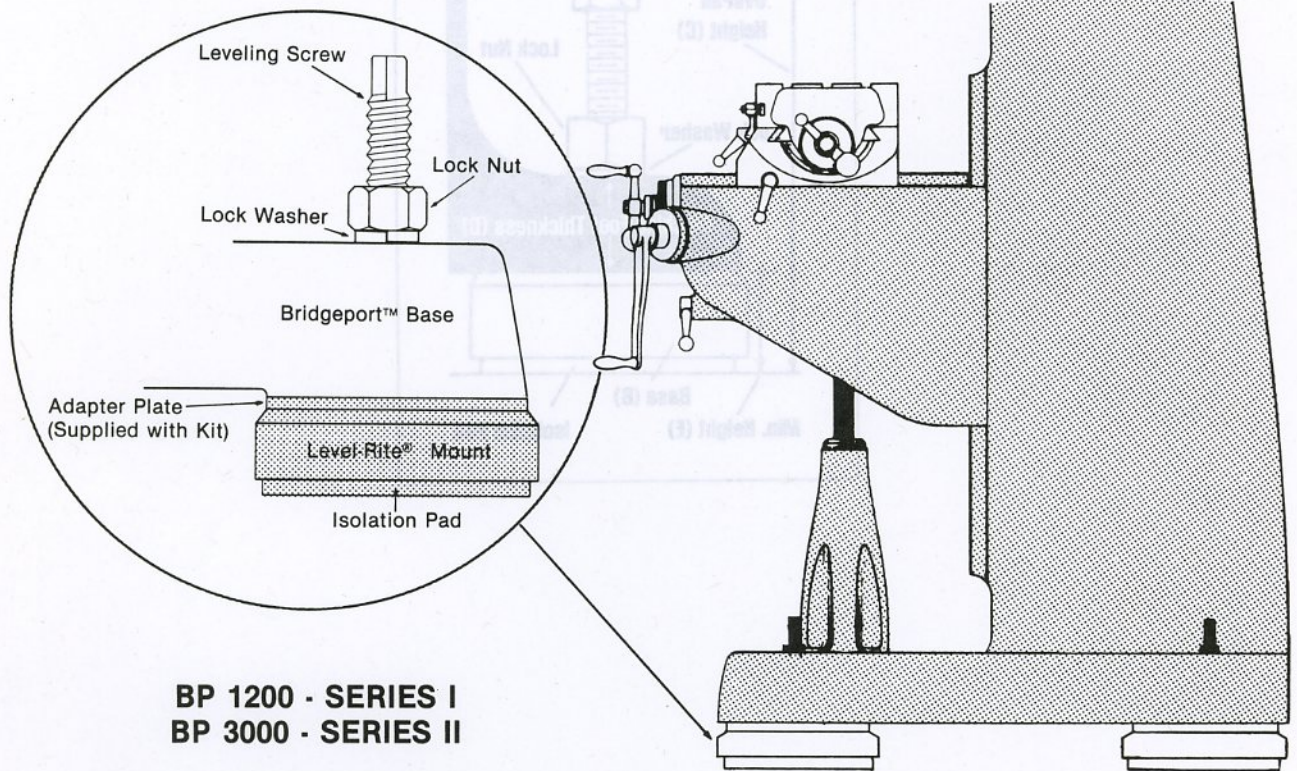

EXTRA-RUGGED DESIGN. SIMPLIFIES LEVELING. DAMPENS VIBRATION, NOISE.

UNISORB BP-1200-Series I and BP-3000-Series II Level-Rite® Mounts are a ruggedly built design combining broad, sturdy construction with improved vibration control. Designed for use with Bridgeport machines, the BP-1200 and BP-3000 are quick and easy to install and require no special modifications or attachments to the Bridgeport base. These self-contained leveling mounts simplify machine installation and eliminate floor damage. No drilling, lagging, adhesives or shims are required.

Accurate leveling is obtained by simply turning the leveling screw. Free-floating action of the leveling screw automatically compensates for uneven or pitched floors. Once adjusted, the lock washer and nut hold the adjustment secure. Furnished complete with UNISORB Red-Line™ Anchor Pads, BP-1200 and BP-3000 Level-Rite® Mounts absorb vibration, reduce noise, and prevent machines from creeping or walking. Properly installed, Level-Rite® Mounts meet OSHA standards for anchoring machinery.

UNEQUALLED VIBRATION DAMPING QUALITIES OF ENGINEERED FELT

For thousands of years man has used felted fiber to absorb shock and vibration. Even with advances in technology in polymer and elastomer chemistry, no other substance to this day equals felt in its ability to isolate against transmitted shock and vibration. UNISORB RED-LINE™ PADS are also highly resistant or impervious to most industrial chemicals, oils and moisture. Life expectancy, in most cases, will exceed that of the machinery with which they are installed.

RED-LINE™ ANCHOR PADS USED ON LEVEL-RITE® MOUNTS

Engineered felt is used to reduce vibration transmission and noise. The nylon/acrylic bonding on the pad provides an extremely high coefficient-of-friction between the pad and the floor surface to provide maximum protection against machine movement without physical anchoring. Pads are unaffected by oils and solutions used in manufacturing plants.

HOLLOW BASE MOUNTING KITS

HOLLOW BASE MOUNTING KITS

Designed for hollow bases as found on the Bridgeport Machines and certain models of lathes , grinders ,etc.

The kit provides vibration control , leveling and support. Each kit includes (4) mounts with special length level adjusting screw and (2) mounting plates.

Specify distance between bolt holes when ordering. Standard kits accomodate these distances :

BP - 1200 KIT	20" - 21.5" (SLOTTED)
BP - 3000 KIT	23" - 24.5" (SLOTTED)
BP - 3000S KIT	26" - 27.5" (SLOTTED)

OTHER SPACINGS AVAILABLE.

BP-1200 KIT FOR SERIES I BRIDGEPORT MACHINE

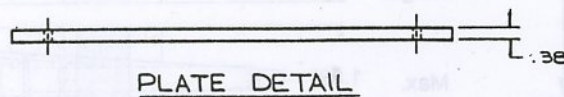
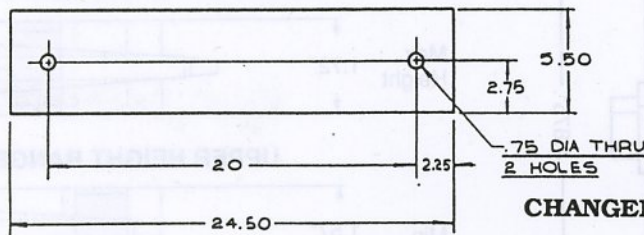
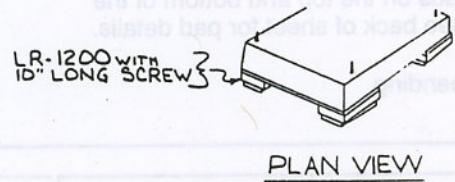
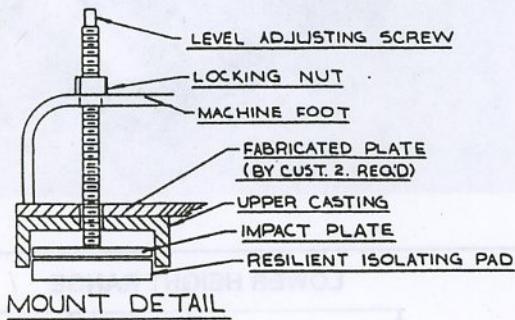

TRI-WEDGE 8000 MOUNTS

Tri-Wedge 8000 Mounts* Load Indicating Machinery Mount Pads*

- Heavy Duty Machinery Mount System
- Two Height Ranges in One Mount
- Load Indicator Mount Pads

- Use For All In-Place Alignment and Leveling
- Pads Provide Vibration Isolation
- Patent Pending Design on Mounts and Pads

This heavy duty mount utilizes two stationary wedges and one sliding wedge to provide mechanical lift for the mount. An adjusting bolt moves the center wedge fore and aft between stationary wedges to provide lift to the top wedge. Two height ranges are provided, based on the position of a retainer within the mount. The retainer (shaded in the drawing below) can be placed in one of two retaining sockets. Placing the retainer in the socket nearest the adjusting bolt head adjusts the mount through the lower height range. Positioning the retainer in the rear socket moves the mount through the upper height range. Weight of the mount without pads is 5 lbs.

Photo at right shows Load Indicating Machinery Mount Pads on the top and bottom of the mount. See back of sheet for pad details.

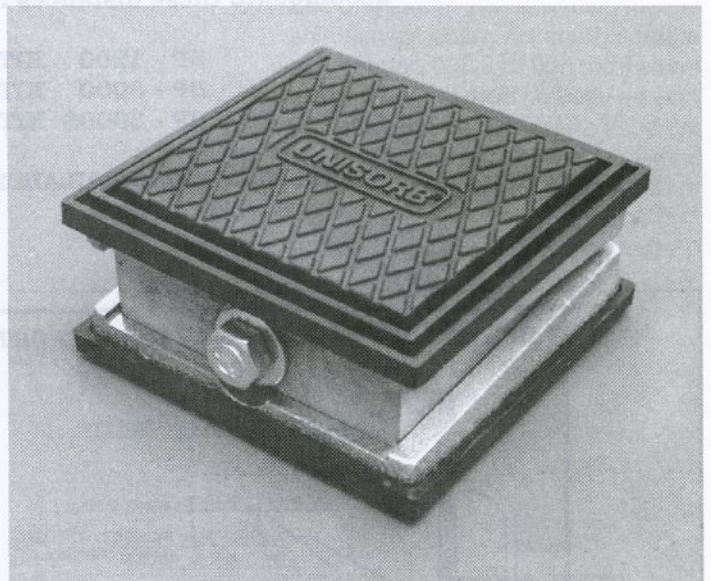

*Patent pending

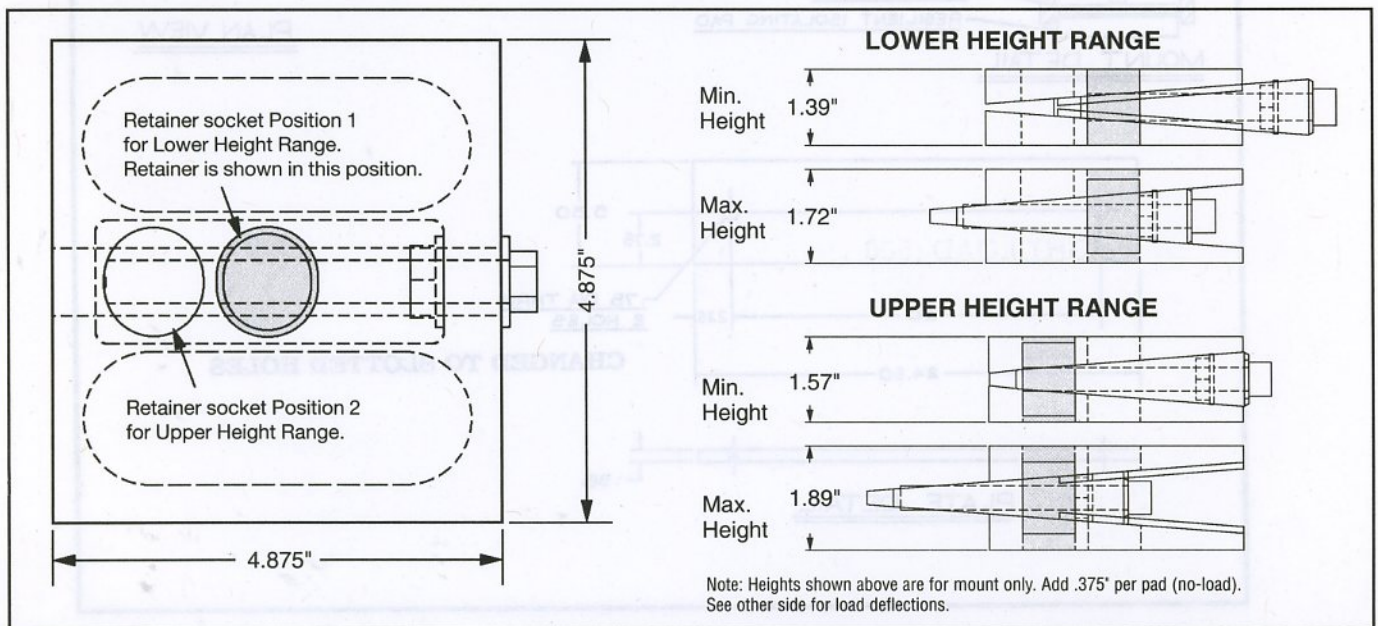

TRI-WEDGE 8000 MOUNTS

Load Indicating Machinery Mount Pads*

Load bearing rings molded into the top surface of the neoprene pads show the amount of load placed on the mount. Two load indicator rings of different heights are moulded in the pad around the perimeter surface. Viewing the deflection of the compressed rings against a machine base shows the approximate weight placed on the mount and pad surface. Pads are made for machine loads from 500 to 8,000 pounds. They may be used on both the top and bottom surfaces of a mount and provide vibration isolation between the mount and machine base and/or floor.

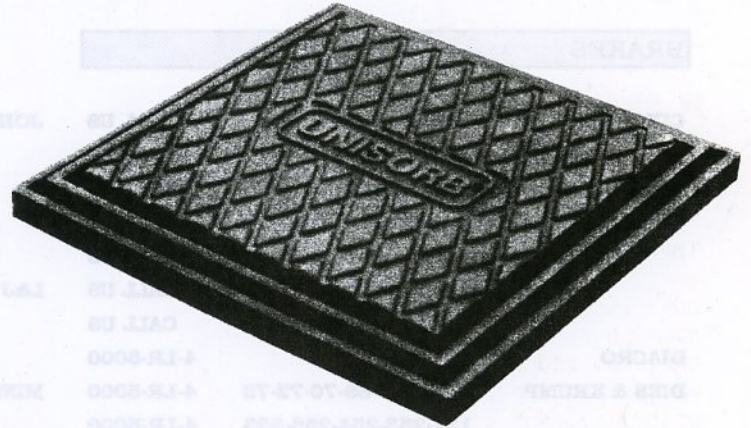

PADS MAY BE USED ON TOP AND BOTTOM OF MOUNTS

*Patent pending

PROFILES SHOWING PAD DEFLECTION

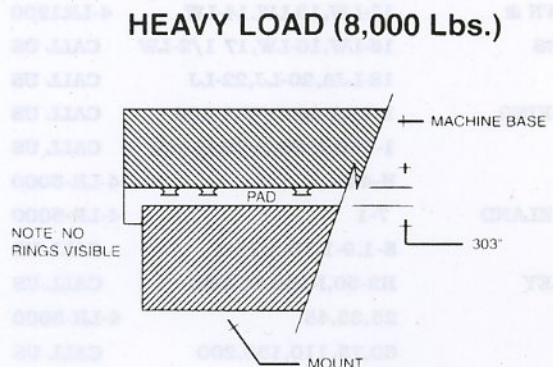
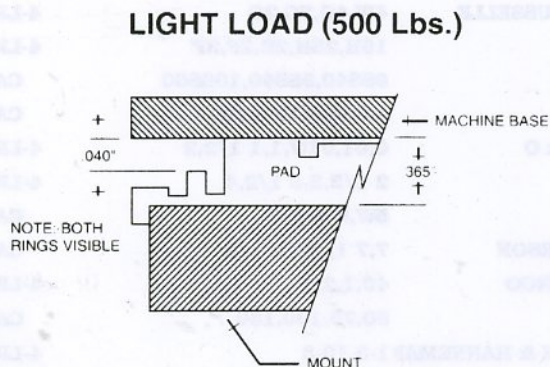
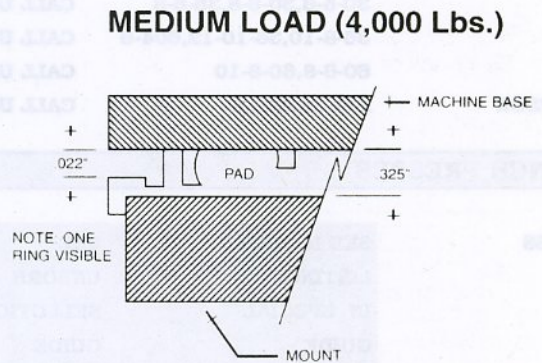
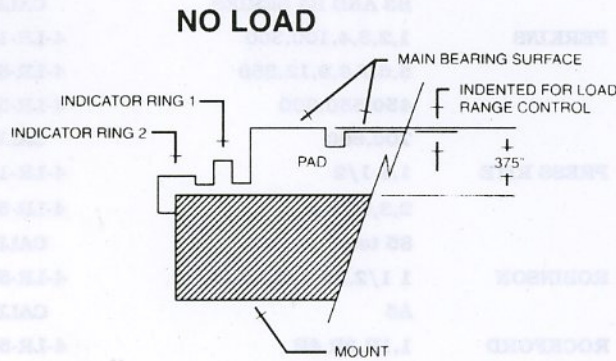

MACHINERY MOUNT APPLICATION GUIDE

BENDING MACHINES

BUFFALO	1/2-O-OA1 1/2 1 WR-2	4-LR-5000 CALL US
PINES	3/4 automatic	4-LR-5000

BRAKES

CINCINNATI	2-30-5', 3-50-6' 3-50-10', 9X10' 90-61,8,10'	CALL US CALL US CALL US
CRYL BATH	100-6,100-8,100-10 120-8,120-10,120-12 150-2,150-4,150-6 150-8,*150-10,150-12	CALL US CALL US CALL US CALL US
DIACRO	36	4-LR-5000
DIES & KRUMP	64-65-67-68-70-72-73 131-253-254-255-333 334-335-338 74-4L6-6L8-8L10-440 406D-408D-410D-454D 456D-458D-504D-506D	4-LR-5000 4-LR-5000 4-LR-5000 CALL US CALL US CALL US
NIAGARA	1B 15-3-4,15-8-10 25-5-6,25-6-8 1B-25-8-10,25-10-12 30-5-6,30-6-8,36-6-8 36-8-10,36-10-12,604-6 60-6-8,60-8-10	4-LR-5000 4-LR-5000 CALL US CALL US CALL US CALL US
VERSON	ALL MODELS	CALL US

PUNCH PRESSES

BLISS	SEE MACHINE LISTINGS IN SPECIAL GUIDE SECTION	SEE UNSORB SELECTION GUIDE SECTION
BROWN & BOGGS	11-LW,13-LW,14-LW 15-LW,16-LW,17 1/2-LW 18-LJA,20-LJ,22-LJ	4-LR1200 CALL US CALL US
CLEARING	1-45,1-60,1-75,1-100 1-150,H-60,H-75,H-100 H-45	CALL US CALL US 4-LR-5000
CLEVELAND	7-1 8-1,9-1,10-1,11-1	4-LR-5000 CALL US
DANLEY	H2-50,I-100,SCZ-50 25,35,45 60,75,110,150,200	CALL US 4-LR-5000 CALL US
DENNISON	DG604,DF4002 D84,HD-10	4-LR-1200 4-LR-5000

FAMCO	52,53,54,55,56,59	4-LR-5000
FEDERAL	0,1,2 3,3 1/2,4,5 55,6,7,7 1/2,8	4-LR-1200 4-LR-5000 CALL US
FERRACUTE	C-1,C-G1 C-2,C-3,C-4,C-5 C-6,C-15,C-16,C-17 C-34,C-35,C-36	4-LR-1200 4-LR-5000 CALL US CALL US
JOHNSON	7,8,G75,10,11 W60,W50 19,3,4 1/2,5,33 44,55	CALL US CALL US 4-LR-5000 4-LR-5000
L&J	0,-1,-2 3,4,4 1/2,5,45 36,27,22,18	4-LR-1200 4-LR-5000 4-LR-5000
MINSTER	SEE MACHINE LISTINGS IN SPECIAL GUIDE SECTION	SEE UNSORB SELECTION GUIDE SECTION
NIAGARA	A1,A1 1/2,A1 3/4,A2 A2 1/4,A2 1/2 A3,A3 1/2 A4,A4 1/2 B3 AND B4 SERIES	4-LR-1200 4-LR-5000 4-LR-5000 CALL US CALL US
PERKINS	1,2,3,4,100,300 5,6,7,8,9,12,350 450,550,600 700,800	4-LR-1200 4-LR-5000 4-LR-5000 CALL US
PRESS RITE	1,1 1/2 2,3,60 ton 85 ton	4-LR-1200 4-LR-5000 CALL US
ROBINSON	1 1/2,A2 1/2,A3,A4 A5	4-LR-5000 CALL US
ROCKFORD	1,1R,3R,4R 6R,6 1/2R,TR	4-LR-5000 CALL US
ROUSSELLE	4W,4G,3G,2G 15H,25H,2E,2F,3F 8SS40,8SS60,10SS60 10SS80,10SS100	4-LR-5000 4-LR-5000 CALL US CALL US
V & O	0,01,01W,1,1 1/2,2 2 1/2,3,3 1/2,4 5W,5 1/2,6	4-LR-5000 4-LR-5000 CALL US
VERSON	7,7 1/2,8,8 1/2	CALL US
WARCO	40,1,2,3 60,75,100,150	4-LR-5000 CALL US
ZEH & HANNEMAN	1-3,10-3 1-6,8-7,8-8,8-9 8-12,9-7,9-9	4-LR-1200 4-LR-5000 4-LR-5000

CONTACT ACORN TOLL-FREE FOR APPLICATION QUESTIONS ON ANY MACHINE.

MACHINERY MOUNT APPLICATION GUIDE

SAWS

DELTA	SPECIFY #	4-LR-5000
DOALL	SPECIFY #	4-LR-5000
KELLER	SPECIFY #	4-LR-5000

SHEARS

CINCINNATI	ALL MODELS	CALL US
STEELWELD	4B-6,4B-8,4B-10	CALL US
	4B-12,6BC-6,6C-8	CALL US
	6C-10,8CD-6,8D-8	CALL US
WYSON & MILES	1096,10HD,672	CALL US

WELDERS

FEDERAL	ALL MODELS	4-LR-5000
TAYLOR WINFIELD	ALL MODELS	4-LR-5000

MACHINERY

BORING MILLS

BICKFORD	FHS4	CALL US
BRYANT	999	4-LR-5000
EXCELLO	SINGLE END 2112B	4-LR-5000
	OBL END 1212B	4-LR-5000
	112,215A,1212A,218	3-LR-5000
FITCHBURG DUPLEX		FIXATOR
GIDDINGS & LEWIS	65H5T	FIXATOR
HEALD	352-122	CALL US
	121-47A	3-LR-5000
KEARNEY & TRECKER	B HORIZONTAL	CALL US
KING	52"-36"	FIXATOR
LUCAS	42-B-60	FIXATOR

BROACHES

AMERICAN	H-10-48,T-10-36	6-LR-5000
	TR-4-24,4-6-24	4-LR-5000
FOOTE BURTE	25-66	CALL US
	5-42	CALL US
LAPOINT	32 HORIZONTAL	CALL US
	V8 VERTICAL	CALL US
	50-100 DRV	CALL US

COMPRESSOR

GARDENER DENVER	ALL MODELS	CALL US
INGERSOLL RAND	ALL MODELS	CALL US
WESTINGHOUSE	ALL MODELS	CALL US

CLICKERS

USMC	ALL MODELS	CALL US
------	------------	---------

DIECASTING

CASTMASTER	10A,15A	CALL US
CLEVELAND	50	CALL US
LESTER ENGINEERING	HP-250-SF	CALL US
	HP-450Z-SF,HP-600Z-SF	CALL US
	HP-250X-SF	CALL US
	HP-450X-SF	CALL US
	HP-700X-SF,HP-900-SF	CALL US
	HP-1200X-SF	CALL US
REED PRENTICE	2G	CALL US
WATSON STELMAN	16ES-400	CALL US

DRILLS

ATLAS	1815	3-LR-1200
ALLEN	3 SPLINLE	4-LR-5000
	DOUBLE SPINDLE	4-LR-5000
AVEY	#1,2,2BMA-6,MA-8	4-LR-5000
	3BMA-6	CALL US
BARNES DRILL	201 1/4,242,262	4-LR-5000
BURGMASER	2BH,2BHT,2BR	4-LR-5000
	25AH	4-LR-5000
	3BH,3BHT,3BHTL	CALL US
CARLTON RADIAL	1A,112X3	CALL US
	3A 11X4,4A-4140	CALL US
CINCINNATI-	21,24",5A-18,3X9	4-LR-5000
BICKFORD	3X11	4-LR-5000
EDLUND	1B-7	4-LR-1200
	1B-12,H2F	4-LR-5000
	2F-12,3B12,4F	4-LR-5000
LELAND GIFFORD	1-2-3MVB	4-LR-5000

FOUR SLIDES

NILSON	1-2-S-1F,S-F-3	6-LR-5000
--------	----------------	-----------

GEAR HOBBERERS

BARBER COLEMAN	3-,6-10,10-12	4-LR-5000
	4-6,8-10,14-15	4-LR-5000
	16-11,16-16,16-36,22-16	CALL US
FELLOWS	36,P-400	CALL US
	4GS	
	3GS	3-LR-5000
	6A	6-LR-5000
	7A	5-LR-5000
HAMILTON	0	4-LR-1200

CONTACT ACORN TOLL-FREE FOR APPLICATION QUESTIONS ON ANY MACHINE.

MACHINERY MOUNT APPLICATION GUIDE

GEAR HOBBER (CONT'D)

MICHIGAN	900	CALL US
MIKRON	120,122,79	4-LR-1200
NEWARK	7	CALL US

GRINDERS

ABRASIVE	M3,M34,1 1/2,38 1218518 3S,18	3-LR-1200-S 3-LR-1200-S 4-LR-5000-S
ARTER	A-3-16,A-8,A-12 B-20,B-24,B-30,B-40 E 12 X 16	4-LR-5000-S CALL US CALL US
BARBER COLEMAN	6-5	CALL US
BLANCHARD	18,11,G15 16-A 36-60	CALL US CALL US CALL US
BOYER-SCHULZ	6-12,6 X18	4-LR-1200
BROWN & SHARPE	#1,2B,2U,4 #5,12 10N	CALL US 4-LR-5000 3-LR-1200
BRYANT	51209 16-28,15-38,24-35 16-16,1330,P4638 2209,2209D	3-LR-5000 CALL US CALL US 4-LR-5000
CINCINNATI	2 CUTTER,2,10,OL 1,6X30,10 PLAIN ER 10X18U,ER 10X36 ER 10X48,ER 10X72 12X36,12X48,12X72 HYDRAULIC	3-LR-5000 CALL US CALL US CALL US CALL US CALL US
COVEL	6X18,10,15,20,22,35,60	4-LR-5000-S
DOALL	D3,D6-1,D6-3,D8-1,D8-3, D10-1,D10-3,G-1,G-10	4-LR-5000 4-LR-5000
EXCELLO	G-3,35,39A 33,33L	CALL US CALL US
GALLMEYER & LIVINGSTON	2D1,2DT,TD1,AD1 BO1,BO2,CO2,O 4,5, 10,12,20,25,28 35,45,55,416,65 8.03504E+13	4-LR-1200 4-LR-1200 4-LR-5000 3-LR-5000 CALL US CALL US
GARDNER	4,14,226,134 11	4-LR-5000-S CALL US
HAMMOND	OK-10,OK-12,WD-10	4-LR-1200
HEALD	50,70,72,221 73281422	CALL US CALL US

GRINDERS

HEALD (CONT'D)	180261361 271 272	CALL US CALL US CALL US
HILL-ACME	24X24X72	FIXATOR
INGERSOLL	30"	4-LR-5000
JONES & LAMSON	12X45,6X36 6X15	CALL US 3-LR-5000
K.O. LEE	3-52,KH	4-LR-1200
LANDIS	H4X18,6-8,4X12 12 1/2,CH537,14X36 14X48 CH-1,CH10X24 1224,14X36	4-LR-5000 CALL US CALL US CALL US CALL US
LE BLOND	2	4-LR-5000
MATTISON	20X28X60 36,#24 ROTARY	FIXATOR CALL US
NORTON	ALL MODELS	CALL US
OLIVER	STD TOOL CUTTER,ARC FAC. 20" TOOL BIT,FACE MILL	4-LR-1200 4-LR-5000
PRESCO	6X18	5-LR-5000
PRATT & WHITNEY	14X36,M-1640,14X60 MD-918	CALL US CALL US
REID	2-3,2G,612H,2A 2B,2C,618	4-LR-5000 4-LR-5000
REISHAUER	ZA	CALL US
SELLERS	6T	4-LR-5000
THOMPSON	TYPE B12X18X25,10X24 BB 12X36 TYPE C 12X17C,14X18C,21X28C 22C,35X42C,29,36,43C 22,30,37,44 TYPEC 24,31,38,45 TYPEC 25,32,39,46 TYPEC 26,33,40,47 TYPEC	CALL US CALL US CALL US CALL US FIXATOR FIXATOR FIXATOR FIXATOR FIXATOR FIXATOR
VAN NORMAN	667,452,462,639,620 67,365,766,615,660 413,615,620,626,630	4-LR-5000-S 4-LR-5000-S 4-LR-5000-S
WARDEVELL	618V	4-LR-5000-S

HAMMERS

CALL ACORN WITH MAKE AND MODEL NUMBER

INJECTION MOLDING MACHINES

CALL ACORN WITH MAKE AND MODEL NUMBER

CONTACT ACORN TOLL-FREE FOR APPLICATION QUESTIONS ON ANY MACHINE.

MACHINERY MOUNT APPLICATION GUIDE

JIG BORERS

SIP	1H	3-LR-5000
	2H,3K	4-LR-5000
FOSDICK	42P,30	CALL US
HAUSER	2A,3BA	3-LR-5000
MOORE	1,2,	4-LR-5000
	1 1/2,3	3-LR-5000
PRATT & WHITNEY	1E,1 1/2	CALL US
	2A	CALL US

LATHES

ACME	2	CALL US
AMERICAN	20X72,16X54,STYLEB	8-LR-5000
	STYLEC	8-LR-5000
	ALL PACEMAKER MODEL	8-LR-5000
ATLAS	63006308	4-LR-1200
	6304	6-LR-1200
AXELSON	B16X78,20X72	FIXATOR
BARDONS OLIVER	7,7 1/2,2 1/2	8-LR-5000
BARER MAUSER	18X120 TYPE L	6-LR-5000
BOYE & ENMES	16 1/2X30,18 1/2X30	8-LR-5000
	22 1/2 X 48	8-LR-5000
	27 1/2X 48	CALL US
	30X108	CALL US
BULLARD	36" VTL 30" CUTMASTER	CALL US
	34",42"	CALL US
CARDIFF	12	4-LR-5000
CINCINNATI	18	8-LR-5000
	12 1/2X42,22 1/2X48	6-LR-5000
	10 1/2X24,18 1/4X24	6-LR-5000
	20 1/2 X48	6-LR-5000
CLAUSING	6524,6505,17",15"	CALL US
GISHOLT	5,3,4,1L	6-LR-5000
	2L,3L,4L,5L	CALL US
	1F,2F	8-LR-5000
HARDINGE	HCT,DSM-59	4-LR-1200
	HLV,DV,HVL-9	4-LR-1200
HENDY	2 16X30,14X54,12X30	8-LR-5000
	14X30	8-LR-5000
JONES & LAMSON	7B-3,7B-3 1/2,7B-4 1/2	8-LR-5000
	9A,10A	8-LR-5000
	9B,10B	CALL US
LE BLOND	12" ENGINE,14",16",17"	8-LR-5000
	20"	8-LR-5000
	25",32"	FIXATOR
	13" REGAL,15",17",19"	4-LR-5000
	21",24"	4-LR-5000
	30",16/38,25/50,32/60	CALL US

LODGE & SHIPLEY	P1,2013X54,2013X178	8-LR-5000
	60TmX25X72,20X144	CALL US
	16X30,14X54,A-12,A-16	8-LR-5000
	16X54,6X78	8-LR-5000
MONARCH	18X144	FIXATOR
	CK-12,W-16",BB-18,C-28	8-LR-5000
	M-20,SERIES 61	8-LR-5000
POTTER JOHNSON	0,000,2,12	CALL US
	P400	CALL US
WARNER & SWASEY	#3,2,4,5	6-LR-5000

MILLING MACHINES

BRIDGEPORT	ALL MODELS	SEE BP KITS
	MOUNTING BKT REG"D	
BROWN & SHARPE	0,000,2,12	4-LR-5000-SP
CINCINNATI	1B,1M	4-LR-5000
	4,5,6,	CALL US
	14-48L	CALL US
CLAUSING	8520	4-LR-1200
DIAMOND	22M	4-LR-1200
GORTON	0-16A,8D,8 1/2D	4-LR-500-SP
	P1-3,P2-3,P3-2	4-LR-500-SP
	2-28,3-34,3-48	CALL US
GREAVES	2H	4-LR-500-SP
KEARNEY & TRECKER	18CH,D,2D,1CE,1CH	4-LR-5000
	3CE,3KM,3CSM	CALL US
	330TF,415-TF	CALL US
KENT-OWENS	1M	4-LR-1200-SP
	2RV	4-LR-5000-SP
MILWAUKEE	2,4,MODEL K&H	CALL US
PRATT & WHITNEY	B 13X30,30",40"	5-LR-5000-SP
	BL3620 KELLERDL	CALL US
SUNDSTRAND	1,0,	4-LR-5000
	22-1224,22-1236,22-1248	CALL US
	33-1872,33-1896	CALL US
	55-1848	CALL US
	33D-1472,55-1872	CALL US
	55-1986,55-18120,55-2496	FIXATOR
	55-24120	FIXATOR
	55-24144,55-24168	FIXATOR
	55D-2496,55D-24120	FIXATOR
	55D-24144,55D-24168	FIXATOR
VAN NORMAN	ALL MODELS	4-LR-5000

SCREW MACHINES

BROWN & SHARPE	00,00G,4	4-LR-500
DAVENPORT	ALL MODELS	4-LR-5000
WARNER & SWASEY	2AC,3AC,M2530	CALL US

SHAPERS

FELLOWS & ONSRUD	ALL MODELS	CALL US
------------------	------------	---------

CONTACT ACORN TOLL-FREE FOR APPLICATION QUESTIONS ON ANY MACHINE.

MACHINERY INSTALLATION SYSTEMS

UNISORB MACHINERY INSTALLATION SYSTEMS Parts List For Model R Level-Rite Mounts

MOUNT	HOUSING SIZE	PAD		LEVELING SCREW O.A.L.	LOCK NUT	LOCK WASHER	LEVELING DISK	
		TYPE	SIZE				DIAMETER	THICKNESS
R-5	3-1/2x3-1/2	SB-1/2	3x3	1/2-13	1/2	1/2	1-3/4	7/8
R-9	3-1/2x3-1/2	SB-1/2	3x3	1/2-13	1/2	1/2	1-3/4	7/8
R-16	4-1/2x4-1/2	SB-1/2	4x4	5/8-11	5/8	5/8	1-3/4	7/8
R-27	3-1/2x3-1/2	FB-1/2	3x3	1/2-13	1/2	1/2	1-3/4	7/8
R-36	6-1/2x6-1/2	SB-1/2	6x6	1-8	1	1	2-1/4	1
R-48	4-1/2x4-1/2	FB-1/2	4x4	5/8-11	5/8	5/8	1-3/4	7/8
R-100	6-1/2x6-1/2	FB-1/2	6x6	1-8	1	1	2-1/4	1

UNISORB MACHINERY INSTALLATION SYSTEMS ISOLATION EFFICIENCY CHART

Unisorb Level-Rite Mount Model U-9

Load On Mount (lbs)	% Isolation At		
	15 Hz	20 Hz	30 Hz 50 Hz
50	--	--	30 85
100	--	--	68 89
150	--	20	75 93
200	--	30	82 94
300	--	55	85 95
400	--	65	86 96
500	20	68	87 96
600	30	70	89 96
700	37	72	90 96
800	40	74	91 96
900	45	75	92 97

MACHINERY INSTALLATION PROCEDURES - U MOUNTS

LEVEL-RITE "U" MOUNTS

INSTALLATION PROCEDURES

1. Clean floor, removing all oil, grease and debris.
2. Bring machine into location and raise sufficiently to allow mounts to be positioned directly under the leveling bolts in the machine feet.
3. Lower machine until all leveling bolts are seated in the dimples in the top of the mounts.
4. Adjust each leveling bolt until machine is level.
5. After 2 hours and 24 hours of operation recheck the machine for level, and readjust as required.

SPECIFICATIONS			
MODEL	MAX LOAD	A HEIGHT	B BASE SIZE
U-5	500	1.00	3 X 3
U-9	900	1.00	3 X 3
U-16	1,600	1.00	4 X 4
U-27	2,700	1.00	3 X 3
U-36	3,600	1.50	6 X 6
U-48	4,800	1.00	4 X 4
U-100	10,800	1.50	6 X 6

Dimensions are in inches.
Weights are in pounds.

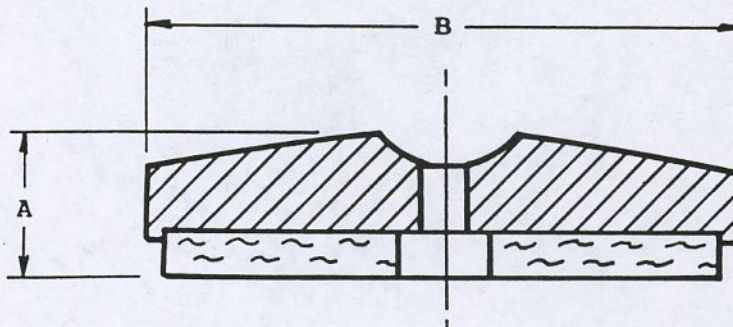

SECTION IV

QUANTUM PM™ PRESS MOUNTS

Introduction	40
Press Mount Considerations	41-43
Press Mount Specifications and Installation Procedures	44-45
Press Mount Criteria	46
Vibration Survey Services & "Smart Mount" Technology	47
Test Results	48-49
Die Turnover Pads	49A-49B

INTRODUCTION

This Quantum PM-Press Mount section presents detailed product information covering this superb line of products. These mounts are part of our Engineered Products line of mounting equipment, and are specifically designed for each press application. It is our intent to completely familiarize you with Quantum PM" Press Mounts while providing technical information supporting our claim to the unequalled quality represented by this line of products.

Quantum PM" Press Mounts have been carefully developed to provide optimum performance, even in the toughest applications, along with unparalleled ease of installation.

Acorn engineering staff and field representatives are always ready to provide design and on-site assistance with your machinery installations to assure maximum product performance.

Contact Acorn Engineering and Sales at 1-800-523-5474 or FAX at 1-800-782-6780.

UNISORB® is a registered trade name of UNISORB® Installation Technologies. Other registered trade names and trademarks in this catalog include:

Quantum PM™ Press Mounts -
Vector™ Anchor Bolts
V-1® Non-Shrink Machinery Grout
V-100® Epoxy Grout
Red-Line Anchor Pads
Titan™ Shock Pads

UNISORB SPECIALIZED ENGINEERING

Established in 1935, UNISORB® has become the nation's leader in the manufacturing of premium quality machinery installation systems.

Unique in its breadth and depth of line, UNISORB® anchoring, leveling, aligning, vibration isolation and noise control devices, systems and accessories will solve almost any equipment installation problem.

UNISORB® has the only engineering staff devoted exclusively to the design and implementation of complete machinery installation systems. These engineering services are typically provided free of charge.

The requirements of each installation are carefully studied to determine the proper combination of devices needed for the system, and a formal engineered proposal presented.

From concept to final installation of a system, UNISORB® can assure optimum performance of mounted equipment with the industry's most experienced staff of designers, application engineers, and field engineers.

In addition, Acorn factory trained field representatives are available during installation and system start-up to assure that maximum performance is attained.

PRESS MOUNT CONSIDERATIONS

All too often presses are installed by simply setting them in place on the shop floor with no consideration for proper installation. Special foundations are sometimes used to provide adequate support, especially with larger tonnage presses. When used without proper support, a multitude of problems can occur, from unwanted vibrations to premature wear of press components to die failure, etc. Due to the excessive shock and vibration caused by the operation of the press, isolation material such as felt, rubber and composite have sometimes been placed under the press feet, and shims used for leveling (see figure 1).

This is a step in the right direction, but does not address the problem of fast, easy, accurate leveling and alignment of the presses, nor of maintaining alignment. For this reason the press mount was developed to provide both ease of leveling and alignment, as well as vibration isolation (see figure 2).

This development has provided cost savings for metalworking operations everywhere. The performance of a

press is greatly affected by how it is installed. The performance of other equipment, as well as personnel, are also influenced by how presses are installed. Presses should be supported in such a manner that the shock and vibration generated in normal operation does not transmit into surrounding areas, thereby disrupting precision machining work and/or contributing to personnel fatigue.

Press mounts have provided a way to allow presses to perform at optimum levels, while reducing the cost of installation, operation and maintenance. Other cost savings include fewer scrap parts and less building damage to floors, foundations, etc.

In order to perform to design specifications, presses must be supported adequately to maintain alignment and critical relationships between press and feed equipment.

The support system for a press must be capable of dealing with:

1. Static loads (dead weight of the press)
2. Stamping impacts and snap through forces
3. Slide inertia forces
4. Rotating out-of-balance forces

To determine whether or not a press is a good candidate for the use of press mounts, let's briefly examine each of the four items listed above.

1. Static loads are the forces seen at each mounting point with the press in operating position, but completely at rest. Most presses have four mounting points, but are constructed so that the weight is not evenly distributed among them. Usually the rear feet are farther from the center line of the slide travel than the front feet. Also, flywheels and drive equipment on mechanical presses are located on one side or another. This uneven distribution of weight must be taken into account when designing any support system. UNISORB® Quantum PM™ Press Mounts make it possible to

compensate for unequal weight distribution by allowing adjustment of loading among the press feet.

2. Stamping impact and snap-through forces are present to some degree in all presses and can be particularly troublesome when higher speed machines are used for blanking. The rapid rate of rise of force as the stock is contacted by the punch moves the press crown upward and the bed downward, stretching the press uprights in the process. At maximum capacity, the uprights of a press could be stretched to their allowable limits. When the work material fractures, the opposite action occurs with the press crown moving downward and the bed upward to its original position, and because of this inertia, slightly beyond. This reaction is called snap-through shock. These forces are magnified by any misalignment condition which exists within the press. Both the stamping impact and snap-through forces can be greatly reduced by proper leveling of the press, thus assuring proper alignment of press components. Press mounts are very useful for controlling these forces and assuring symmetrical loading of the press structure, thus greatly enhancing component life.

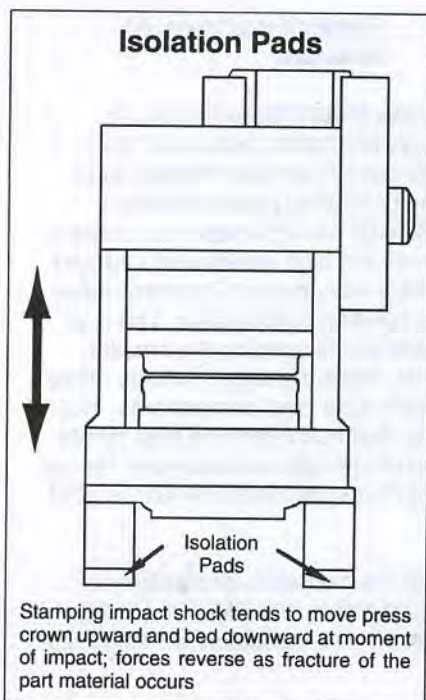

FIGURE 1

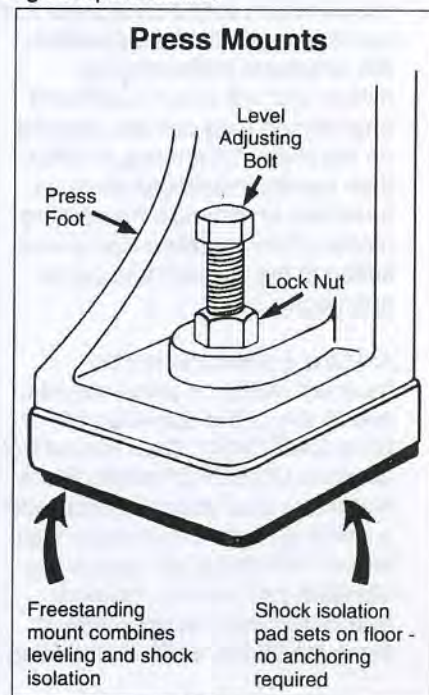

FIGURE 2

PRESS MOUNT CONSIDERATIONS

3. Slide inertia forces result from acceleration forces acting on the slide and are an extremely important consideration in the design of a press mounting system. They act primarily in the direction of slide travel and tend to alternately lift the press from its supporting surface and push it back into its supporting surface. In some high speed presses it is possible for these forces to exceed the dead weight of the press. This condition establishes a limitation as to whether or not a press should be mounted on freestanding mounts. Machines which are manufactured with dynamic balancing equipment do not have this problem, and can safely be mounted on press mounts. Older high speed presses should be securely bolted down, and are good candidates for isolated foundations (see figure 3).

4. Rotating out-of-balance forces result from crankshaft imbalance and produce a rocking of the press about its mounting points. This problem is usually found in older presses which do not have dynamic balancing equipment, and which are being operated at high speeds. In cases like this, proper action must be taken to restrain the press. When this condition exists on a press it is possible to predict by calculation the amplitude of the rocking motion that will occur if sufficient engineering data can be obtained on the press. Otherwise, a stiffer than normal installation must be furnished to minimize the rocking motion. This condition also is well suited to the isolated foundation approach.

Anytime a press cannot be mounted safely on press mounts due to any of the above conditions, UNISORB® offers the perfect solution. UNISORB® Inertia Block materials, used in conjunction with a well engineered foundation with proper anchoring, will reduce the vibration and impact problems associated with the operation of these machines, while maintaining

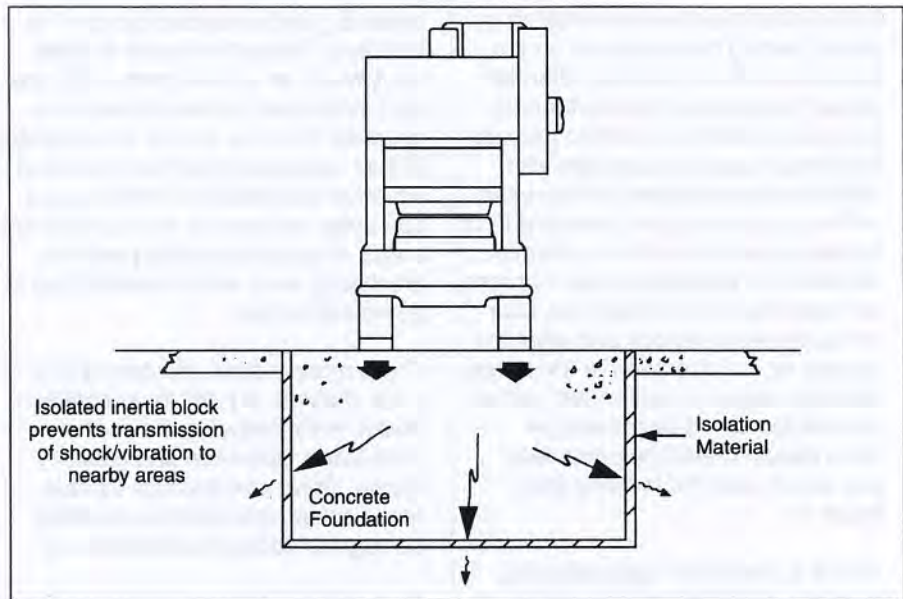

FIGURE 3

the rigidity needed for proper support. In some cases presses have been mounted using both press mounts and inertia blocks, thus providing ease of leveling while further tuning out vibration problems. Contact UNISORB® Engineering for more information about the inertia block isolation materials.

In lieu of constructing an isolated foundation, UNISORB® isolation pads can be placed under the press feet, and the press securely bolted to the floor, with leveling accomplished by the use of shims. UNISORB® Vector™ Anchor Bolts, together with either UNISORB® V-1® Non-Shrink Machinery Grout (cement-based) or Standard V-100® Epoxy Grout, can be used to anchor the press feet to the floor. Contact UNISORB® Engineering for more information on these fine products.

By utilizing press mounts whenever possible, anchor bolts, steel plates, shims and grouting materials can be eliminated, thus saving time and money. Any savings in labor and down time can be considered to be significant financial gain. These savings also can be realized any time a press is relocated. Other savings which can be

attributed to the use of press mounts are related to reduced maintenance of presses dies, foundations and floors.

Two very important design considerations should be taken into account when press mount evaluations and selections are made:

- A. Press mount construction
- B. Isolation pad material selection

A. Press Mount Construction is critically important because of the tremendous pounding inflicted upon the mount during press operation UNISORB® has optimized the balance between the high quality and strength of ductile cast iron and fabricated ales for its housing construction. The duo tile cast iron is used on the smaller mounts, while the larger mounts utilize the fabricated steel components. The ductile cast iron offers the best combination of strength and economy for our smaller Press Mounts (PM-81 thru PM 161).

Due to the necessity for flexibility of size and shape, the PM-201 models and larger are manufactured using fab-

PRESS MOUNT CONSIDERATIONS

ricated steel. All the UNISORB® **Quantum PM™ Press Mount** components are rugged enough to suit any press application. UNISORB® has the option of using fabricated steel for any of its press mount sizes if the need for special size or shape mounts arises. UNISORB® **Quantum PM™ Press Mounts** have also maintained the popular design feature of the spherical dimple in the impact plate under the adjusting bolt to allow for angular correction for uneven floors. For the above reasons UNISORB® has maintained its position as the most versatile supplier of press mounts in the industry.

B. Isolation pad material selection is paramount because it determines the degree of proper vibration isolation and environmental conformity which may be achieved by using press mounts. The design and construction of UNISORB® **Quantum PM™ Press Mounts** provides the capability of choosing from a wide variety of isolation products. These products are selected on the basis of their individual characteristics to meet your exact isolation needs. This flexibility provides the opportunity to maximize vibration isolation and take into account shape factors, environmental conditions, spring rates, etc. Therefore UNISORB® is not restricted to the use of any one type of pad material. UNISORB® elastomeric pads are molded to exacting specifications to achieve optimum shock, damping and vibration control. UNISORB® Red-Line Anchor Pads have been used for over 50 years, and provide excellent vibration control and damping, especially for smaller machines. UNISORB® Titan™ Shock Pads also provide excellent vibration control and damping, especially under extreme loads and high shock applications. A combination of Red-Line Anchor™ Pads or Elastomeric Pads together with Titan Shock Pad inserts offer the

perfect solution to solving the vibration/isolation problems on larger presses (see Figure 5). UNISORB® Elastomeric Pads are impervious to fluid absorption and provide excellent isolation and damping. The high quality molded compound is superior to industrial neoprenes in oil resistance and damping. Urethanes and other elastomers are also available to meet the special requirements of the Food and Drug Administration and the U.S. Department of Agriculture.

UNISORB® **Quantum PM™ Press**

Mounts have a special "Friction Kote" available on the bottom surface of the resilient pads to prevent presses from "walking" on shop floors.

Finally, as "the proof of the pudding is in the eating," so "the value of a press mount is in the performance." UNISORB® **Quantum PM™ Press Mounts** outperform others in reducing shock and vibration. Please see pages 48-49 of this catalog for vibration curves illustrating this.

UNISORB® has many satisfied press mount customers, and a list of referrals is available on request.

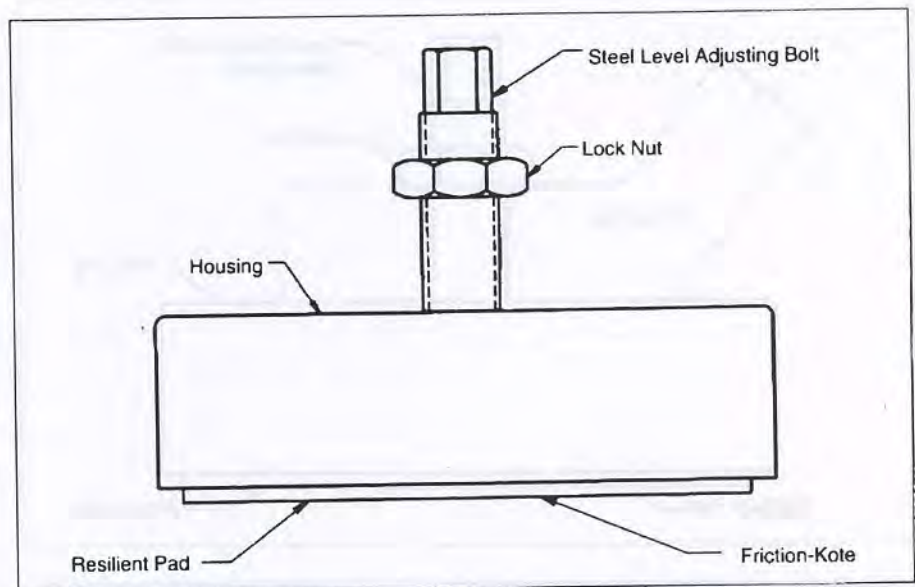

FIGURE 4

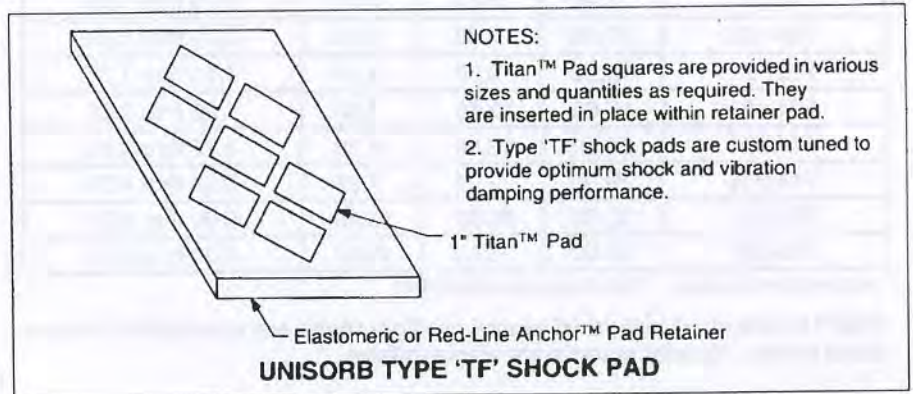
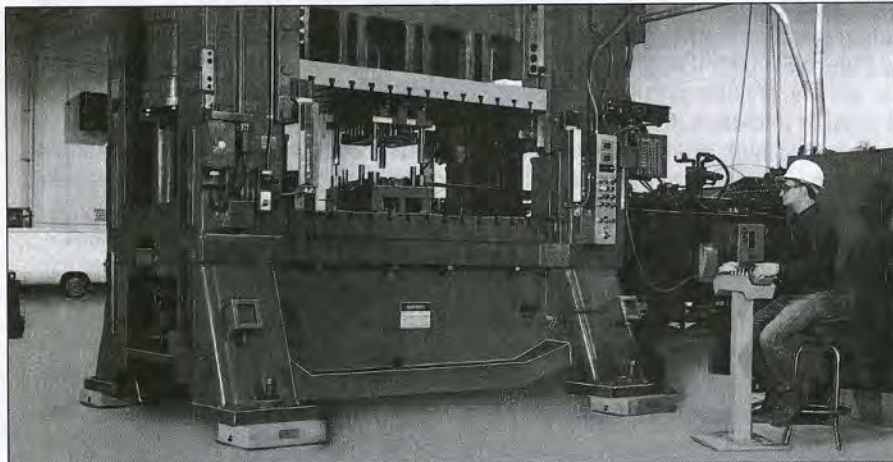
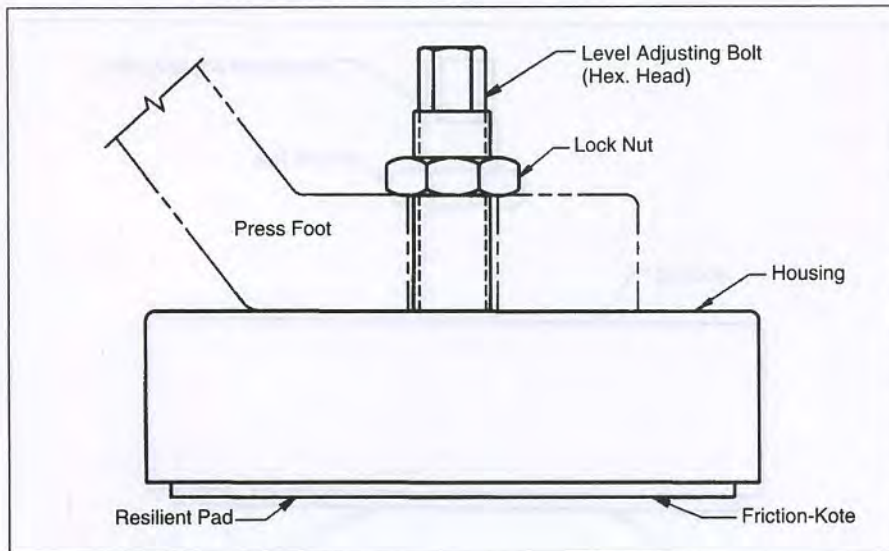

FIGURE 5

PRESS MOUNT SPECIFICATIONS AND INSTALLATION PROCEDURES



UNISORB® PRESS MOUNTS UNDER 600 TON STAMPING PRESS



SPECIFICATIONS				
PRESS MOUNT SERIES	LENGTH	WIDTH	HEIGHT* (min.)	BOLT SIZES AVAILABLE
PM-81	8.00	5.88	2.50	0.75 thru 1.25
PM-101	10.00	7.88	3.25	0.75 thru 1.50
PM-121	12.50	9.00	3.50	1.00 thru 1.75
PM-161	16.00	12.50	4.50	1.25 thru 2.25
PM-201	20.00	16.00	6.00	1.75 thru 3.00
PM-261	26.00	22.00	7.50	2.50 thru 4.00
PM-321	32.00	24.00	10.50	3.00 thru 5.00
PM-381	38.00	25.50	13.00	4.00 thru 6.00

All dimensions in inches. *Top of mount housing to floor.

Over 150 standard individual mount configurations are available to fit your exact needs. Special mounts are also available.

Proper press installation is critical to achieving optimum performance.

UNISORB® *Quantum PM™* Press Mounts offer the following benefits:

- Increased press life
- Increased tooling life
- Simplified press installation
- Fast, accurate alignment
- Reduced shock and vibration
- Elimination of anchor bolts
- Reduced need for special foundations
- Reduced operator fatigue
- Reduced motor loads
- Uneven floors accommodated
- Press "Walking" prevented

UNISORB® *Quantum PM™* Press Mounts are considered engineered products, and as such are custom applied by UNISORB® engineers to meet the specific requirements of each press application. The unit consists of four main components:

1. Rugged steel housing assembly
2. Heavy duty steel impact plate
3. High strength steel adjusting bolt
4. High quality resilient isolation pad

A broad variety of isolation pad materials and configurations are available to meet the requirements of almost any press application. These pad options include:

- Specially engineered felt and felt derivatives
- UNISORB® Titan™ pad for high impact loading and shock
- Type 7F Pads for "fine-tuning" mounts for larger, heavier presses
- Specially engineered and formulated elastomeric pads

Eight standard sizes are available ranging from 8 inch length to 38 inch (see specification chart). Special sizes and configurations are also available as required. Contact Acorn Engineering Department for design assistance.

PRESS MOUNT SPECIFICATIONS AND INSTALLATION PROCEDURES

INSTALLATION PROCEDURES

1. Clean floor, removing all oil, grease and debris.
2. Bring press into location and raise it sufficiently to allow mounts to be positioned under the mounting feet.
3. Remove the leveling bolts from mounts. Keep each leveling bolt and mount together as a set so the stamped number on the housing and the bolt head match.
4. Position mounts (with bolt holes aligned with holes in press feet) and insert leveling bolts through bolt holes in press feet and screw into bolt holes in mounts.
5. On the PM-81 series only, adjust each mount with the leveling bolt so the pad extends below the mount housing approximately 1/4". (All other mounts will automatically be positioned this way.)
6. Lower press onto mounts so all mounts accept uniform loading.
7. After 20 minutes (allowing the press to "settle in") locate the mount housing closest to the floor and elevate it to 1/4" off the floor. Level the press by adjusting the other mounts using the first mount as the point of reference. On large presses it may be necessary to assist lifting the press by external means while adjusting leveling bolts. On the PM81 series mounts the maximum amount of pad showing below housing should not exceed 5/8".
8. The torques on the leveling bolts should be relatively equal, signaling even load distribution.
9. Add flat washers if necessary to adequately cover holes in press feet. A lock washer may also be added if desired.
10. Tighten nuts, thus securing press feet to mounts.



ENGINEER ADJUSTS PRESS MOUNT

PRESS MOUNT MODEL NAME LEGEND

Press Mount Model PM-121 (7.5)-125(15)-TR

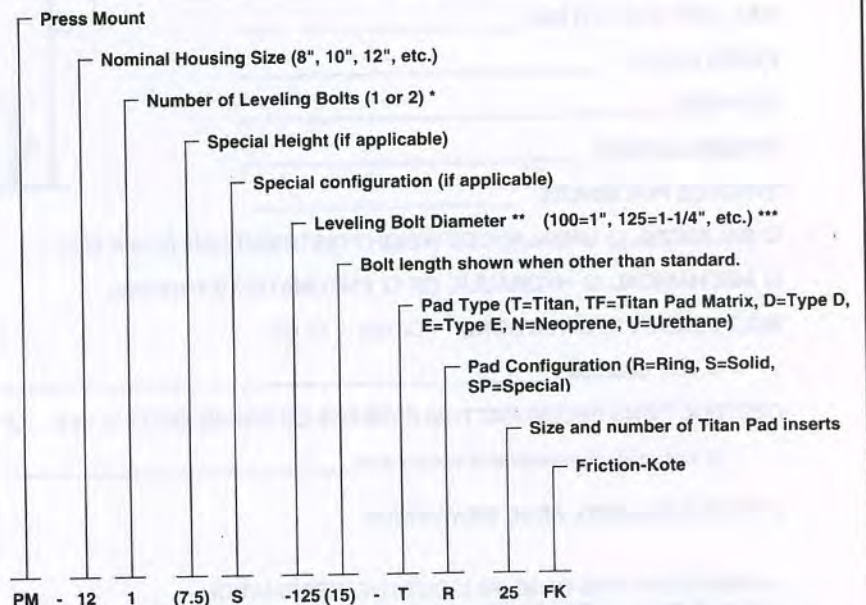

* If press foot requires (2) leveling bolts, contact UNISORB Engineering for application assistance.

** Verify that clearance hole is suitable for leveling bolt.

*** For step-down leveling bolts, show diameter of upper portion of bolt first, then lower portion, (i. e., 125/175).

PRESS MOUNT CRITERIA

The following information is for use in calculating the proper mounting arrangement for presses. Please provide as much of this information as possible.

PRESS MANUFACTURER: _____

PRESS TYPE (Underline one): OBI, OBS, S/S, OTHER _____

PRESS MODEL: _____

PRESS SERIAL NO: _____

PRESS CAPACITY (Tons): _____

PRESS WEIGHT: _____

DIE WEIGHT (Max.): _____

PRESS FUNCTION: BLANKING DRAWING EMBOSSING OTHER _____

MACHINE FOOT DIMENSIONS:

A _____ E _____ I _____

B _____ F _____ J _____

C _____ G _____ K _____

D _____ H _____

FOOT THICKNESS: _____

MAX. TOP WASHER DIA.: _____

PRESS HEIGHT: _____

BED SIZE: _____

STROKE LENGTH: _____

STROKES PER MINUTE: _____

BALANCED, UNBALANCED WEIGHT DISTRIBUTION? (Check one)

MECHANICAL, HYDRAULIC OR PNEUMATIC? (Check one)

BOLT LENGTH RESTRICTIONS: Yes No

If Yes, describe _____

OBSTRUCTIONS BELOW BOTTOM SURFACE OF PRESS FEET? Yes No

If Yes, give dimensions of obstruction _____

IF PIT IS REQUIRED, SEND DRAWING(S)

PLEASE COPY THIS PAGE, FILL OUT THE INFORMATION AND FAX OR MAIL TO ACORN FOR FREE PRESS MOUNT DESIGN SERVICE. FAX NUMBER IS 1-800-782-6780

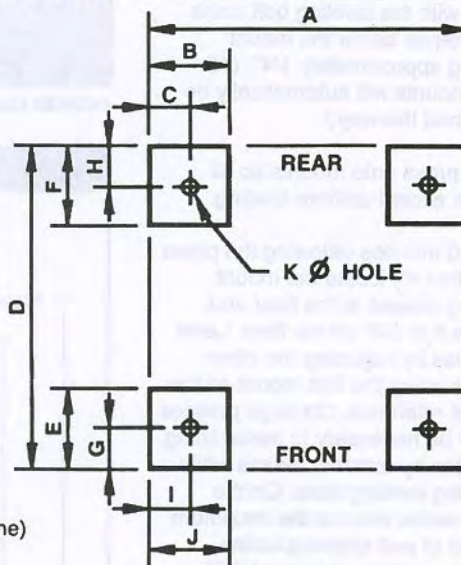

VIBRATION SURVEY SERVICES AND "SMART MOUNT" TECHNOLOGY

VIBRATION SURVEY SERVICES

UNISORB® provides vibration analysis service as part of its overall engineering assistance program to meet every customer's machinery installation need. Our engineers are thoroughly trained in the use of state-of-the-art vibration analyzing equipment and are experienced in analysis of technical data collected for virtually all machinery shock and vibration installation problems.



ENGINEER MEASURES VIBRATIONS

Solving difficult machinery installation problems by providing comprehensive engineered solutions is our primary mission.

UNISORB® engineers have performed vibration surveys in the field for many years and have identified the dominant frequency ranges typically found in shop and plant environments. This information has guided UNISORB® in the engineering and development of its Press Mounts in providing the proper isolation from these troublesome frequencies. The floor/soil system response to externally generated vibrations influences the effectiveness of any isolation system and must be included in a complete analysis.

Ambient vibrations are detected by using highly sensitive seismic accelerometers. These devices are capable of measuring the entire frequency spectrum, including the typically troublesome low frequencies and low amplitude movements which may affect performance of precision machinery.

Vibratory signals Processed in FFT analyzers are capable of looking at time domains and frequency components of all signals. By knowing the exact ambient conditions, an efficient isolation system can be developed.

Contact the Acorn Engineering Department for further information on our Vibration Survey Services.



ENGINEER PROCESSES VIBRATION INFORMATION

UNISORB® "SMART MOUNT" TECHNOLOGY PROVIDES A GREATLY IMPROVED APPROACH IN OPTIMIZING PRESS PERFORMANCE

UNISORB® expertise in performing field evaluations and analyzing vibration signatures from all types of rotating and reciprocating equipment has led to the development of Advanced Dynamic Analysis Techniques for determining actual press operating conditions and proper mount adjustment. By comparing vibration spectra from individual press mounts it is possible to assure that the resolution of dynamic forces generated during operation are symmetrically resolved by the mounting system. This important breakthrough in analytical techniques has provided an excellent tool to provide an even better environment for the press being installed.

Relatively simple and easily learned analysis techniques (often using

equipment already owned by the user) provide an "up and running" look at the forces seen by each mount including how these forces are being resolved. This technique is more cost effective and accurate than "steady state" or static load analysis in assuring optimal mount usage.

Special mount modifications or "single purpose" analysis equipment are not required as the collection of data simply requires the application of a vibration transducer to an exterior mount surface. The mounts do not require any modification whatsoever although transducer mounting locations for permanent transducer attachment can be provided by the factory for applications where mount accessibility is limited.

"Smart Mount" analysis also provides a means of monitoring ongoing changes in the press or its mounting system for the future. Once base line data has been established for a given press, subsequent "check ups" are easily performed (without down time) to verify operating conditions or detect potential problems.

Contact your Acorn representative or call our Engineering Department to learn more about this and other aspects of our state-of-the-art approaches to maximizing your return on machinery investment.

**For More Information
Call 1-800-523-5474**

TEST RESULTS

UNISORB® *Quantum PM™* Press Mounts have a proven track record of successful press installation, the results of which have been documented by vibration surveys.

The overall vibrations (measured on the floor compared to the press foot) are virtually eliminated when mounted on UNISORB® *Quantum PM™* Press Mounts. By comparison, the reduction seen on competitors' multilayer composition pads can be as low as 7%. The actual differences were 7%, 41%, 33% and 42% for an average reduction of 31% on the competitors' pad.



ENGINEERS PREPARE TO MEASURE VIBRATIONS

VIBRATION SPECTRUM FROM 0-200 HZ

200 TON PRESS MOUNTED ON COMPETITOR'S MULTI LAYER COMPOSITION PADS

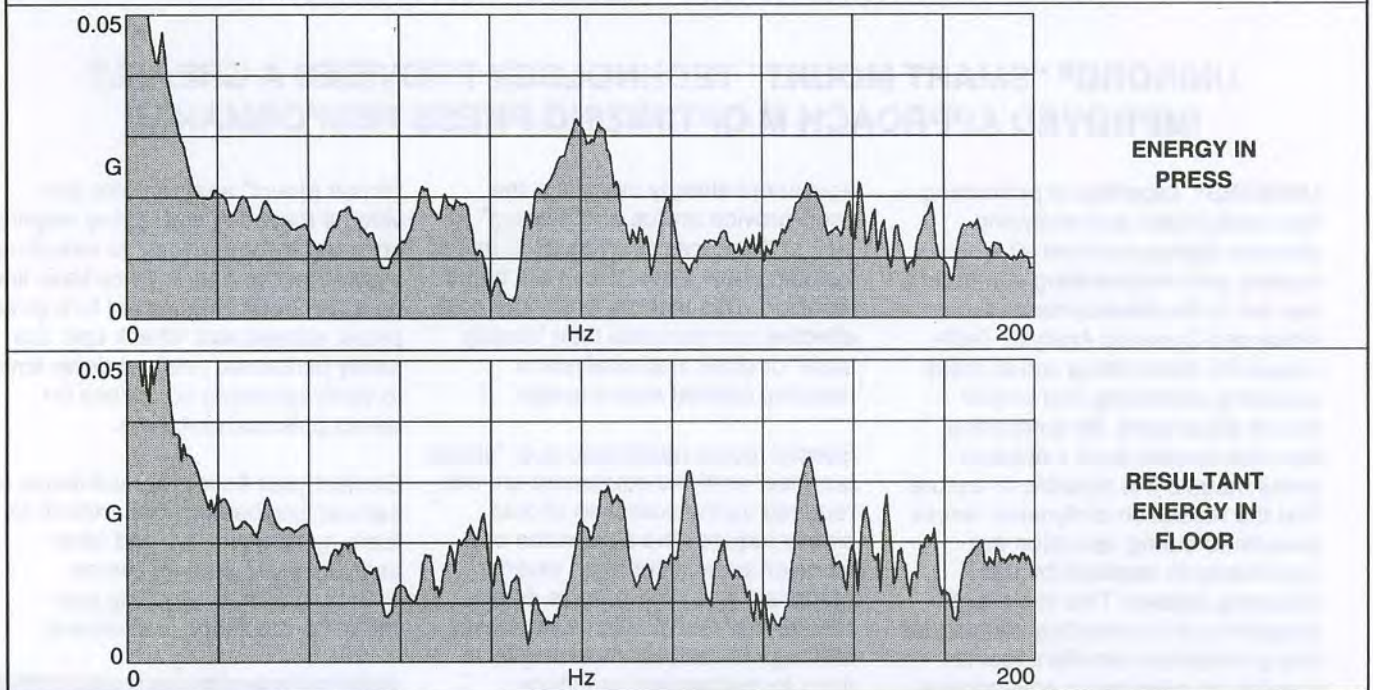

COMPETITOR RESULTS

TEST RESULTS

The same press was installed on UNISORB® *Quantum PM™* PressMounts

PM-121-125-TR. Vibrations (when measured from the press foot to the floor)

are virtually eliminated as indicated on the lower curve shown below.



ENGINEER PRINTS RESULTS OF VIBRATION SPECTRA



ENGINEERS ORGANIZE A VIBRATION SURVEY REPORT

VIBRATION SPECTRUM FROM 0-200 HZ

200 TON PRESS MOUNTED ON UNISORB *Quantum PM™* Press Mounts MODEL PM-121-125-TR

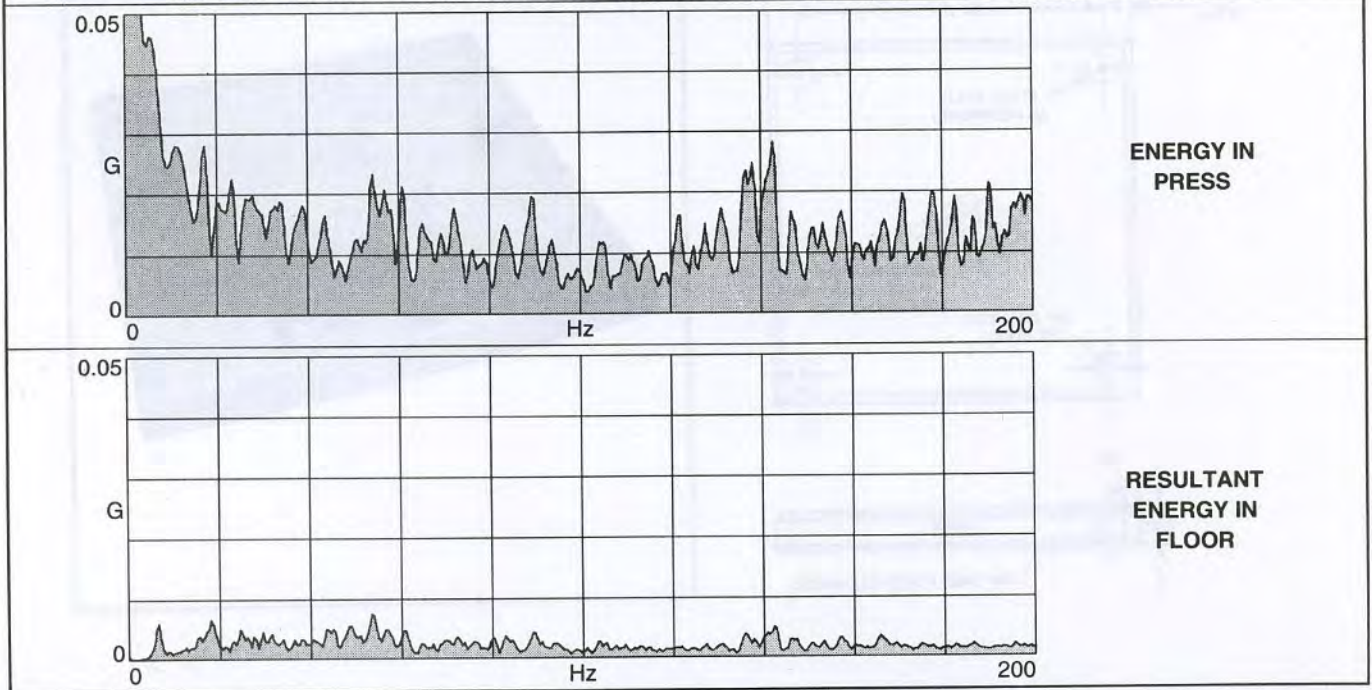

UNISORB® RESULTS

DIE TURNOVER PADS

UNISORB® DTP-24-250

Unisorb® Die Turnover Pads are designed to replace creosote wood blocks or other flooring methods in die manufacture or repair areas. The 2' x 2' x 2 1/2" thick pads provide a convenient size for handling and placement in floor die handling areas. Pads are fastened to the floor using Unisorb® chemical anchors for a long lasting installation.

- Simple and cost effective means of providing a resilient work surface, eliminating handling damage on precision dies.
- Complete, ready to install, requiring no maintenance (anchoring kits available).
- Capable of withstanding continuous heavy traffic and extreme loads imposed by the heaviest dies.
- Precision molded 80 durometer neoprene.
- Heavy steel backing plate to facilitate anchoring.
- High friction texture and self-draining diamond surface pattern.

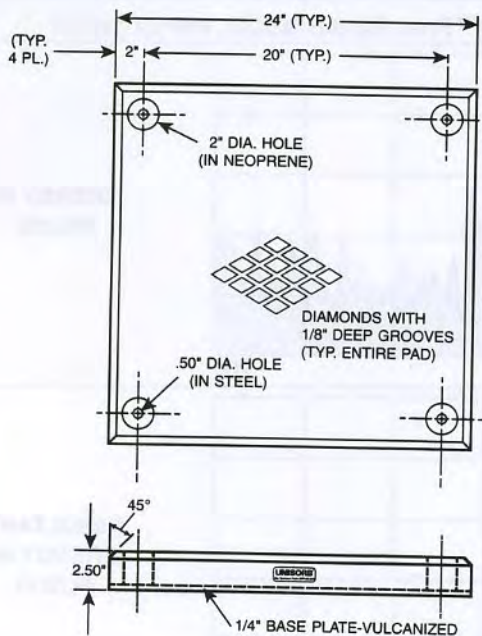

DIE TURNOVER PADS

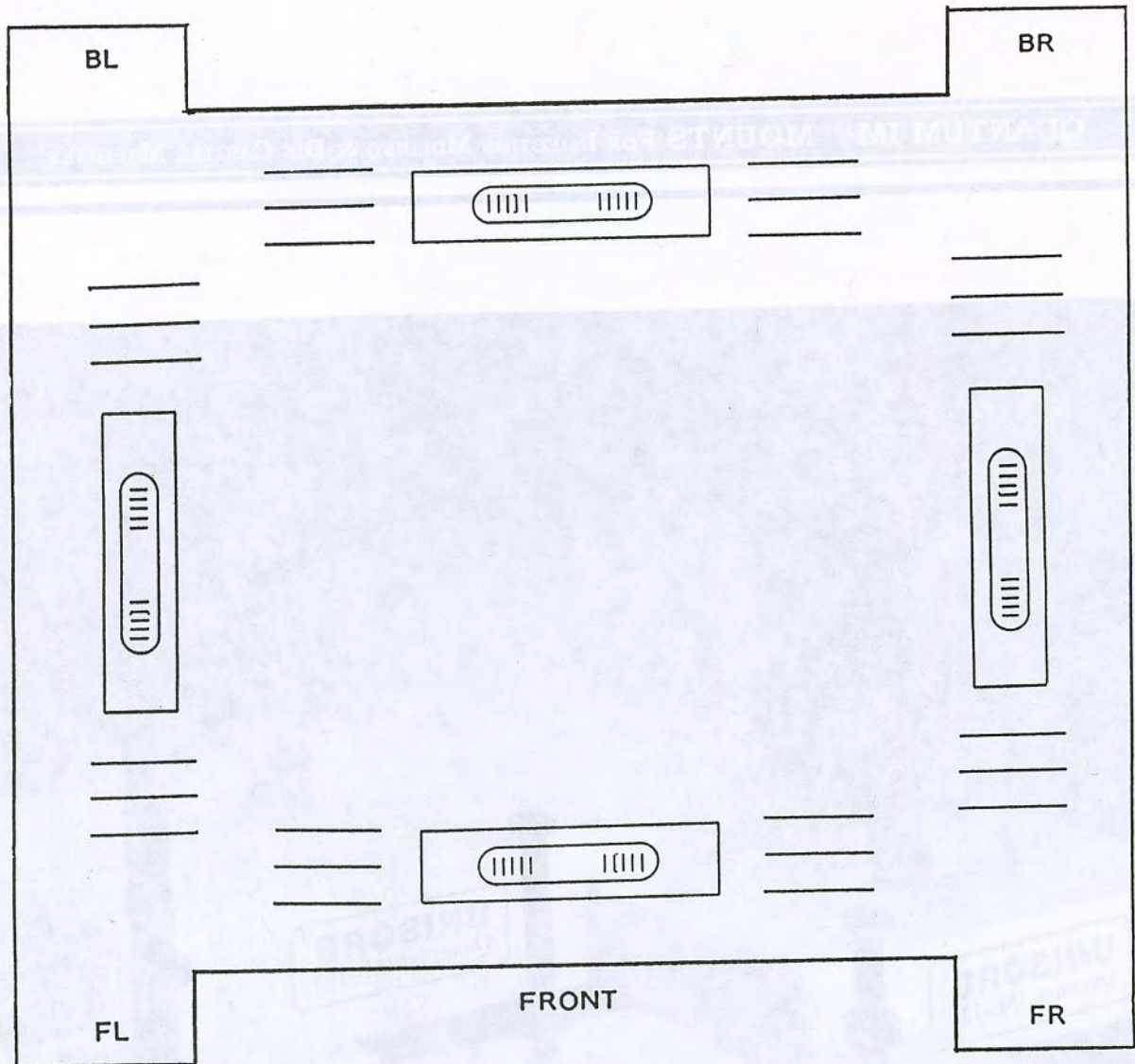

SECTION V

QUANTUM IM™ MOUNTS FOR INJECTION MOLDING & DIE CASTING MACHINES

Quantum IM™ Mounts Introduction.....	52-53
Quantum IM™ Mounts Benefits	54
Quantum IM™ Mounts Product Codes & Specifications	55

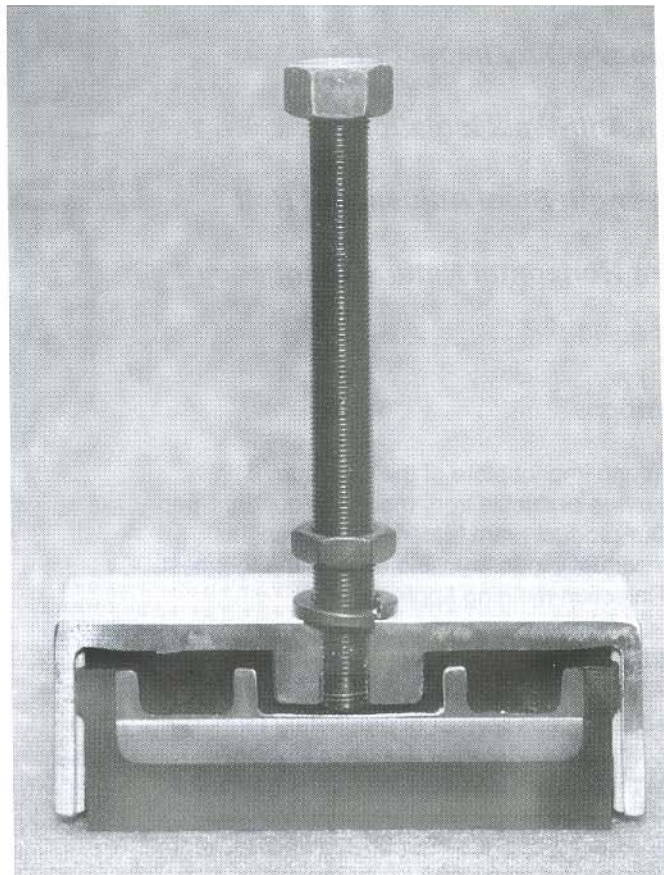

**DESIGNED SPECIFICALLY FOR
HORIZONTAL FORCES
IM-61-075-N90**

QUANTUM IM™ MOUNTS INTRODUCTION

Unisorb's new patent-pending line of **Quantum IM™ Mounts** has been thoroughly engineered and tested to accommodate injection molding and die casting machines of any size. From the smallest of machines to large 4,500 ton machines, **Quantum IM™ Mounts** are the safest, most durable mounts available.

The Maximum Adjustment Range

These mounts are truly a quantum leap in machine mount technology. Every model in the **Quantum IM™** line provides an overall adjustment range of 1-3/8 inches. This range goes well beyond all of Unisorb's competitors worldwide. In addition, Unisorb's line of **Quantum IM™ Mount's** is available in a wide variety of sizes and configurations, and all share these time-tested durability features:

- ***Rugged Ductile Housing***
- ***Super Heavy-Duty Impact Plate***
- ***Resilient Anti-Walk Isolation Pad***
- ***High-Strength Steel Adjustment Bolt***
- ***Constant Horizontal Natural Frequency***

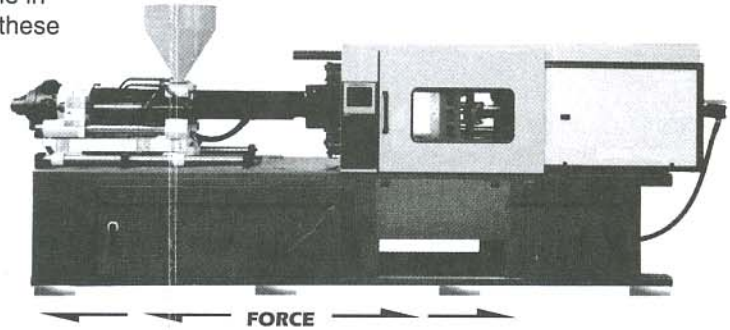

Every mount includes the new patent-pending "constant horizontal natural frequency" feature which is found only in Unisorb **Quantum IM™** Mounts. This design provides consistent performance at any adjustment height.

The Housing

The housing and impact plate of the Quantum IM™ Mounts are made of ductile iron, meeting Foundry Spec. 65-45-12. Our product team tested and proven this design to be virtually indestructible even in the toughest high-speed injection molding applications.

The Isolation Pad

All mount isolation pads consist of proprietary formulated elastomers. The unique internal design of Unisorb's Quantum IM™ Mounts eliminates the interdependence between vertical adjustment and horizontal stiffness found in other mount designs. Our design ensures that each mounting point presents identical horizontal and vertical load deflection characteristics to the machine regardless of adjustment height.



- Patent-Pending

QUANTUM IM™ MOUNTS INTRODUCTION

The Adjusting Bolt

The true hex head adjusting bolt is made with high-strength Grade 5 steel to withstand punishment that would shear off most other bolts. In addition, the finer thread pitch on the adjusting bolt provides greater mechanical advantage and offers a higher degree of accuracy in adjustment, making installation convenient and foolproof. Standard bolts are provided with English threads. Metric threads and special bolt lengths are available upon request.

Precision Engineering for Horizontal Impact

The isolation pad is engineered for a precision fit inside the housing. This tight fitting design yields smoother, quieter operation and longer mount life. The sure fit of the isolation pad enhances the mount's ability to absorb the horizontal impact forces caused by machine operation.

Weight and Force are Distributed Evenly

The unique patent pending design of the isolation pad to mount housing interface results in the uniform distribution of applied forces. The Quantum IM™ Mounts are unmatched in controlling extreme machine induced dynamic loads. This eliminates the walking, excessive machine motion and mount failures typical of general purpose mounts in these applications.

Prevents Machine Walking

The rectangular shape of the Quantum IM™ Mount is yet another advantage. While providing greater resistance to machine "walking" than circular mounts the straight, leading edge-surface on the rectangular mount has proven to be more geometrically stable. This helps eliminate pad roll and entrapment of coolants and oils beneath the pad. In addition, each isolation pad is engineered to possess an exceptionally high coefficient of friction that also prevents machine walking.

***Rectangular Mount
Prevents Walking***

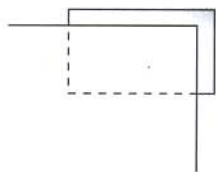

***Round Mount
Subject to Walking***

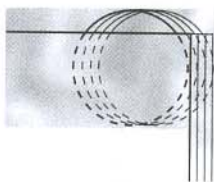

QUANTUM IM™ MOUNTS - BENEFITS

Quantum IM™ Mounts Offer the Following Benefits:

- Reduction of shock and vibration
- Compensation for horizontal impact/force
- Prevention of machine "walking"
- Simplification of machine installation
- Elimination of anchor bolts
- Fast, accurate alignment
- Accommodation of uneven floors
- Increased equipment life

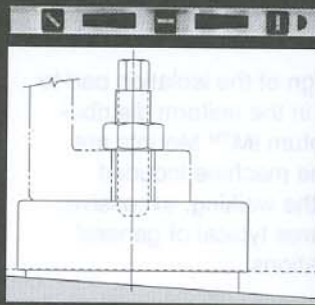

The plate and housing are designed to interact with the isolation pad and the hex head adjusting bolt to yield optimum performance even when floors are as much as 6 degrees out of level.

The revolutionary design of the *Quantum IM™* Mount line maximizes the use of vertical space within the housing. This means that each of the models is capable of making adjustments up to 1-3/8 inches!

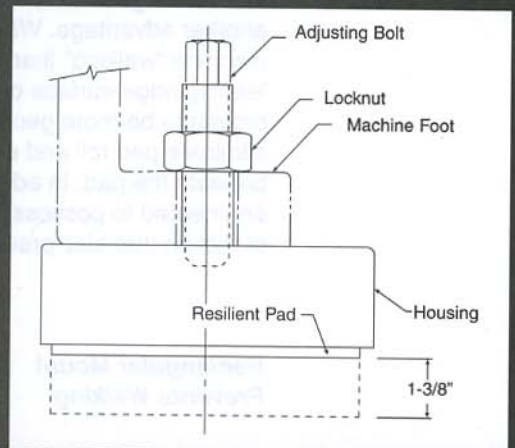

Every detail has been thoroughly considered. The *Quantum IM™* Mounts are electro-powder coated in high visibility "safety yellow" for workplace safety. In addition, the rectangular shape of the housing saves floor space and fits machine profiles better to avoid obstruction of walkways.

PRODUCT CODES & SPECIFICATIONS

The Industry's Most Extensive Range of Size and Configuration

A wide variety of different mount sizes and configurations are available to meet the requirement of any injection molding or die casting machine application. All of the *Quantum IM™* Mounts are height compatible, so it is possible to mix and match different sized mounts to accommodate differing load configurations. Custom-sized *Quantum IM™* Mounts are also available upon request.

QUANTUM IM MOUNTS - INCHES

Mount	Product Code	Length	Width	Height Min. / Max.	Bolt Size	Max. Load (lbs.)
IM-51-050-N90	475802	5.50	3.50	2.50 / 3.88	1/2-13	3,000
IM-51-062-N90	475804	5.50	3.50	2.50 / 3.88	5/8-11	3,000
IM-61-050-N90	475812	7.00	4.50	2.50 / 3.88	5/8-11	6,000
IM-61-075-N90	475814	7.00	4.50	2.50 / 3.88	3/4-16	6,000
IM-61-100-N90	475815	7.00	4.50	2.50 / 3.88	1-14	6,000
IM-71-075-N90	475822	8.00	5.00	2.50 / 3.88	3/4-16	9,000
IM-71-100-N90	475824	8.00	5.00	2.50 / 3.88	1-14	9,000
IM-81-075-N90	475832	8.00	5.88	2.50 / 3.88	3/4-16	9,000
IM-81-100-N90	475834	8.00	5.88	2.50 / 3.88	1-14	12,000
IM-81-100-NTS	475835	8.00	5.88	2.50 / 3.88	1-14	16,000
IM-81-125-NTS	475837	8.00	5.88	2.50 / 3.88	1 1/4-12	16,000
IM-101-100-NTS	475844	10.00	7.88	3.25 / 4.63	1-14	16,000
IM-101-125-NTS	475845	10.00	7.88	3.25 / 4.63	1 1/4-12	25,000
IM-101-150-NTS	475847	10.00	7.88	3.25 / 4.63	1 1/2-12	25,000
IM-121-100-NTS	475854	12.50	9.00	3.50 / 4.88	1-14	16,000
IM-121-125-NTS	475856	12.50	9.00	3.50 / 4.88	1 1/4-12	25,000
IM-121-150-NTS	475858	12.50	9.00	3.50 / 4.88	1 1/2-12	35,000
IM-121-175-NTS	475859	12.50	9.00	3.50 / 4.88	1 3/4-12	35,000
IM-161-125-NTS	475864	16.00	12.50	4.50 / 5.88	1 1/4-12	25,000
IM-161-150-NTS	475866	16.00	12.50	4.50 / 5.88	1 1/2-12	35,000
IM-161-175-NTS	475868	16.00	12.50	4.50 / 5.88	1 3/4-12	48,000
IM-161-200-NTS	475869	16.00	12.50	4.50 / 5.88	2-12	60,000
IM-161-225-NTS	475870	16.00	12.50	4.50 / 5.88	2 1/4-12	60,000