

Caster Type	Page #
GHKU Series Kingpinless Casters .....	2-5
GHKU SS Series Kingpinless Stainless Steel Caster .....	6-8
170 Series Casters.....	9-15
40 Series Hybrid Kingpin Casters .....	16-19
27/FT/28 Series Casters.....	20-27
31 Series Kingpin Casters .....	28-31
05 Series Kingpin Stainless Steel Casters .....	32-36
40 Series Casters.....	37-39
100 Series Pneumatic Casters .....	40

ALL WHEELS ARE AVAILABLE WITH  
PRECISION BALL BEARING, CENTER PIECE & END CAPS  
FOR MANUAL OR TOWING TO FIT IN 2-1/2" HUB LENGTH RIGS  
See Wheel Section for complete selection.

# GHKU TOTAL LOCK SERIES KINGPINLESS CASTERS

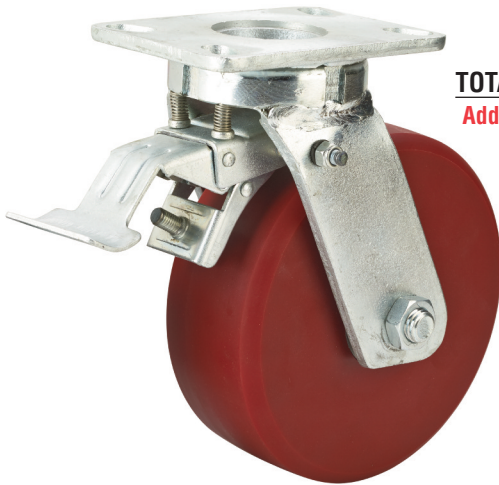

## LEADING SIDE TOTAL LOCK SWIVEL CASTER

Add TL to swivel caster number

Available Toe Guard TO

## NEW TRAILING SIDE TOTAL LOCK SWIVEL CASTER

No need to move cots back and forth  
for finding the brake pedal.

Add TLT to swivel caster number

Available in 6" & 8"

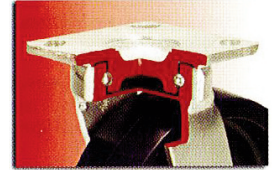
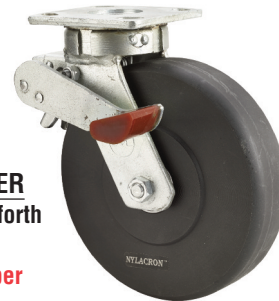

Swivel Head Section

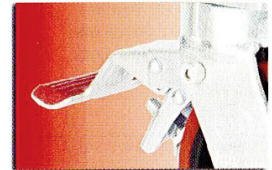

Total Lock System

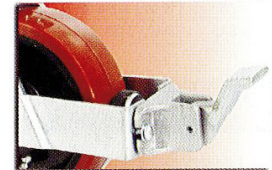

Wheel Face Break



Directional Lock

## 2,000 LBS. LOAD CAPACITY FORGED KINGPINLESS TYPE CASTERS

- Single piece Drop Forged AISI 1045 Steel Top Plate and Fork Base
- Precision CNC Machined Raceways with Kingpinless construction
- Induction Hardening of Raceways ensures uniform depth of hardness
- Totally Sealed Swivel Head with Grease Nipple
- 1/4" Thick Fork Legs robotically welded inside & outside to 2 1/2" fork spacing
- 1/2" Wheel axle
- 4 Position Foot Operated Directional Lock Slots
- Finish: Bright Zinc Plated

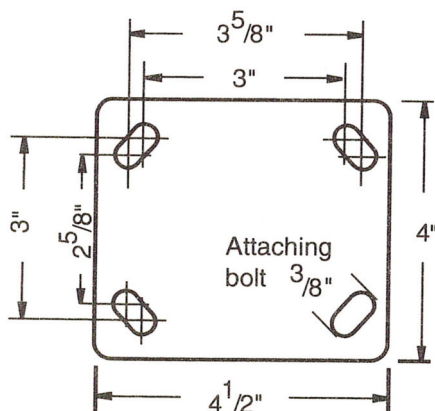

### TOP PLATE

4 X 4-1/2

### BOLT HOLE CENTER

2-5/8 X 3-5/8

SLOTTED TO

3 X 3

### ATTACHING BOLT SIZE

3/8

### RIG OPTIONS

**DL:** FOOT OPERATED  
4-WAY DIRECTIONAL LOCK

**WFB:** WHEEL FACE BRAKE  
ADD TO SUFFIX  
TO THE CASTER PART NUMBER

# 4

# GHKU TOTAL LOCK SERIES KINGPINLESS CASTERS

## SAS WHEELS

### HIGH CAPACITY POLYURETHANE TREAD WHEELS CAST IRON CORE

- Polyurethane firmly bonded to Precision Machined Cast Iron Core
- 93+ 3 Shore A
- Low rolling resistance, smooth and noiseless running

- Non-marking and floor protective
- High abrasion, cut and tear resistant
- Precision Ball Bearings
- Temperature Range: -40°F to +180°F
- **Available in Anti-Static add "AS" after wheel**



Part Number Swivel Caster	Part Number Swivel with Total Lock	Part Number Rigid Caster	Wheel Diameter (inch)	Tread Width (inch)	Load Capacity (lbs)	Overall Height (inch)	Swivel Radius (inch)	Swivel Radius w/Total Lock (inch)	Swivel Radius w/Wheel Brake (inch)
GHKU42SSAS	GHKU42SSASTL	GHKU42RSAS	4	2	900	5-5/8	3-3/16	4	8-1/2
GHKU52SSAS	GHKU52SSASTL	GHKU52RSAS	5	2	1200	6-1/2	3-7/8	4	9-1/2
GHKU62SSAS	GHKU62SSASTL	GHKU62RSAS	6	2	1650	7-1/2	4-9/16	6	10
GHKU82SSAS	GHKU82SSASTL	GHKU82RSAS	8	2	2000	9-1/2	6	6	11-1/2

## ME WHEELS

### ERGONOMIC POLYURETHANE DONUT TREAD WHEELS CAST IRON CORE

- For Low Push-Pull Efforts
- Polyurethane firmly bonded to Precision Machined Cast Iron Core
- Red Tread 93+ 3 Shore A
- Non-marking and floor protective

- Tread Options:  
Softer 80A - Yellow Tread (specify ME-Z)  
Harder 73D - Blue Tread (specify ME-F)
- Precision Ball Bearings
- Temperature Range: -40°F to +180°F
- **Available in Anti-Static add "AS" after wheel**



Part Number Swivel Caster	Part Number Swivel with Total Lock	Part Number Rigid Caster	Wheel Diameter (inch)	Tread Width (inch)	Load Capacity (lbs)	Overall Height (inch)	Swivel Radius (inch)	Swivel Radius w/Total Lock (inch)	Swivel Radius w/Wheel Brake (inch)
GHKU42SME	GHKU42SMETL	GHKU42RME	4	2	775	5-5/8	3-3/16	4	8-1/2
GHKU52SME	GHKU52SMETL	GHKU52RME	5	2	1000	6-1/2	3-7/8	4	9-1/2
GHKU62SME	GHKU62SMETL	GHKU62RME	6	2	1250	7-1/2	4-9/16	6	10
GHKU82SME	GHKU82SMETL	GHKU82RME	8	2	1700	9-1/2	6	6	11-1/2

## SZS WHEELS

### ELASTIC POLYURETHANE TREAD WHEELS CAST IRON CORE

- Polyurethane firmly bonded to Precision Machined Cast Iron Core
- 85+ 3 Shore A
- Excellent for power towing applications

- Reduced noise due to cushioning of loads, Lively Polyurethane allows wheels to "Flex and Roll" over debris
- Non-marking and floor protective
- Precision Ball Bearings
- Temperature Range: -40°F to +180°F
- **Available in Anti-Static add "AS" after wheel**



Part Number Swivel Caster	Part Number Swivel with Total Lock	Part Number Rigid Caster	Wheel Diameter (inch)	Tread Width (inch)	Load Capacity (lbs)	Overall Height (inch)	Swivel Radius (inch)	Swivel Radius w/Total Lock (inch)	Swivel Radius w/Wheel Brake (inch)
GHKU42SSZS	GHKU42SSZSTL	GHKU42RSZS	4	2	550	5-5/8	3-3/16	4	8-1/2
GHKU52SSZS	GHKU52SSZSTL	GHKU52RSZS	5	2	775	6-1/2	3-7/8	4	9-1/2
GHKU62SSZS	GHKU62SSZSTL	GHKU62RSZS	6	2	1000	7-1/2	4-9/16	6	10
GHKU82SSZS	GHKU82SSZSTL	GHKU82RSZS	8	2	1450	9-1/2	6	6	11-1/2

SEN  
WHEELS

## SOLID ELASTOMER WHEEL NYLON CORE

- 70 Shore (D) durometer
- FDA standards for use in food processing environments
- 100% washable

- Glass-filled nylon core insert endures heat
- High impact and abrasion resistant
- Resists oil, grease, water, and most solvents
- Temp Range: -50°F to +180°F



Part Number Swivel Caster	Part Number Swivel with Total Lock	Part Number Rigid Caster	Wheel Diameter (inch)	Tread Width (inch)	Load Capacity (lbs)	Overall Height (inch)	Swivel Radius (inch)	Swivel Radius w/Total Lock (inch)	Swivel Radius w/Wheel Brake (inch)
GHKU42SSEN	GHKU42SSENTL	GHKU42RSEN	4	2	1500	5-5/8	3-3/16	4	8-1/2
GHKU52SSEN	GHKU52SSENTL	GHKU52RSEN	5	2	1800	6-1/2	3-7/8	4	9-1/2
GHKU62SSEN	GHKU62SSENTL	GHKU62RSEN	6	2	2000	7-1/2	4-9/16	6	10
GHKU82SSEN	GHKU82SSENTL	GHKU82RSEN	8	2	2000	9-1/2	6	6	11-1/2

## SJS WHEELS

POLYURETHANE TREAD WHEELS  
CAST IRON CORE

- Polyurethane tread wheels firmly bonded to Precision Machined Cast Iron Core
- 93 + 3 Shore A
- Low rolling resistance; Smooth and noiseless running
- Non-marking and floor protective

- Good abrasion and cut resistance
- Ideal for medium duty applications
- Precision Ball Bearings
- Temperature Range: -40°F to +180°F
- **Available in Anti-Static add "AS" after wheel**

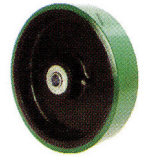

Part Number Swivel Caster	Part Number Swivel with Total Lock	Part Number Rigid Caster	Wheel Diameter (inch)	Tread Width (inch)	Load Capacity (lbs)	Overall Height (inch)	Swivel Radius (inch)	Swivel Radius w/Total Lock (inch)	Swivel Radius w/Wheel Brake (inch)
GHKU42SSJS	GHKU42SSJSTL	GHKU42RSJS	4	2	700	5-5/8	3-3/16	4	8-1/2
GHKU52SSJS	GHKU52SSJSTL	GHKU52RSJS	5	2	1000	6-1/2	3-7/8	4	9-1/2
GHKU62SSJS	GHKU62SSJSTL	GHKU62RSJS	6	2	1200	7-1/2	4-9/16	6	10
GHKU82SSJS	GHKU82SSJSTL	GHKU82RSJS	8	2	1500	9-1/2	6	6	11-1/2

## MDW WHEELS

## DUCTILE CAST STEEL WHEELS

- Machined tread face
- Crown tread face makes maneuverability easy
- Higher load capacities compared to cast iron wheels

- Suitable for extra heavy loads towed in punishing conditions
- High abrasion and oil resistance
- Precision Ball Bearings
- Temperature Range: 800°F

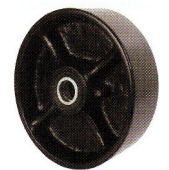

Part Number Swivel Caster	Part Number Swivel with Total Lock	Part Number Rigid Caster	Wheel Diameter (inch)	Tread Width (inch)	Load Capacity (lbs)	Overall Height (inch)	Swivel Radius (inch)	Swivel Radius w/Total Lock (inch)	Swivel Radius w/Wheel Brake (inch)
GHKU42SMDW	GHKU42SMDWTL	GHKU42RMDW	4	2	1500	5-5/8	3-3/16	4	8-1/2
GHKU52SMDW	GHKU52SMDWTL	GHKU52RMDW	5	2	1550	6-1/2	3-7/8	4	9-1/2
GHKU62SMDW	GHKU62SMDWTL	GHKU62RMDW	6	2	2000	7-1/2	4-9/16	6	10
GHKU82SMDW	GHKU82SMDWTL	GHKU82RMDW	8	2	2000	9-1/2	6	6	11-1/2

## DF WHEELS

## HOT FORGED STEEL WHEELS

- AISI 1045 steel with machined tread faces
- Virtually indestructible and easy to maneuver
- High abrasion and oil resistant

- Can be used in the roughest of applications on the poorest of floors
- Precision Ball Bearings
- Temperature Range: -150°F to +800°F

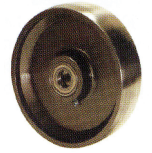

Part Number Swivel Caster	Part Number Swivel with Total Lock	Part Number Rigid Caster	Wheel Diameter (inch)	Tread Width (inch)	Load Capacity (lbs)	Overall Height (inch)	Swivel Radius (inch)	Swivel Radius w/Total Lock (inch)	Swivel Radius w/Wheel Brake (inch)
GHKU42SDF	GHKU42SDFTL	GHKU42RDF	4	2	1800	5-5/8	3-3/16	4	8-1/2
GHKU52SDF	GHKU52SDFTL	GHKU52RDF	5	2	2000	6-1/2	3-7/8	4	9-1/2
GHKU62SDF	GHKU62SDFTL	GHKU62RDF	6	2	2000	7-1/2	4-9/16	6	10
GHKU82SDF	GHKU82SDFTL	GHKU82RDF	8	2	2000	9-1/2	6	6	11-1/2

## NY/MD WHEELS

## NYLACRON™ WHEELS

- Precision Machined from Cast Polyamide. Hardness 112-120 Rockwell R
- Ultimate choice for extremely high load applications to replace metallic wheels
- Offer very high abrasion resistance and very low rolling resistance under extreme loads

- Resistant to salt, grease, alcohol and mild acids - can be used in corrosive applications with appropriate bearings
- Precision Ball Bearings
- Temperature Range: -40°F to +270°F

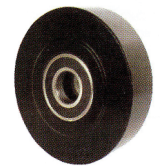

Part Number Swivel Caster	Part Number Swivel with Total Lock	Part Number Rigid Caster	Wheel Diameter (inch)	Tread Width (inch)	Load Capacity (lbs)	Overall Height (inch)	Swivel Radius (inch)	Swivel Radius w/Total Lock (inch)	Swivel Radius w/Wheel Brake (inch)
GHKU42SNYMD	GHKU42SNYMDTL	GHKU42RNYMD	4	2	2000	5-5/8	3-3/16	4	8-1/2
GHKU52SNYMD	GHKU52SNYMDTL	GHKU52RNYMD	5	2	2000	6-1/2	3-7/8	4	9-1/2
GHKU62SNYMD	GHKU62SNYMDTL	GHKU62RNYMD	6	2	2000	7-1/2	4-9/16	6	10
GHKU82SNYMD	GHKU82SNYMDTL	GHKU82RNYMD	8	2	2000	9-1/2	6	6	11-1/2

## NY/MC WHEELS

## NYLACRON™ WHITE WHEELS

- Precision Machined from cast polyamide hardness 112-120 Rockwell R
- Ultimate choice for extremely high load applications to replace metallic wheels
- Offer very high abrasion resistance and very low rolling resistance under extreme loads

- Resistant to salt, grease, alcohol and mild acids - can be used in corrosive applications with appropriate bearings
- Precision Ball Bearings
- Temperature Range: -40°F to +270°F



Part Number Swivel Caster	Part Number Swivel with Total Lock	Part Number Rigid Caster	Wheel Diameter (inch)	Tread Width (inch)	Load Capacity (lbs)	Overall Height (inch)	Swivel Radius (inch)	Swivel Radius w/Total Lock (inch)	Swivel Radius w/Wheel Brake (inch)
GHKU42SNYMC	GHKU42SNYMC TL	GHKU42RNYMC	4	2	2000	5-5/8	3-3/16	4	8-1/2
GHKU52SNYMC	GHKU52SNYMC TL	GHKU52RNYMC	5	2	2000	6-1/2	3-7/8	4	9-1/2
GHKU62SNYMC	GHKU62SNYMC TL	GHKU62RNYMC	6	2	2000	7-1/2	4-9/16	6	10
GHKU82SNYMC	GHKU82SNYMC TL	GHKU82RNYMC	8	2	2000	9-1/2	6	6	11-1/2

Swivel-EAZ™ Wheels available. Durometers: 70A (Black), 80A (Red), 95A (Blue), 60D (Gray), 75D (Black)

See wheel section for load ratings.

# 4

## GHKU KINGPINLESS STAINLESS STEEL TOTAL LOCK SERIES CASTERS



**LEADING SIDE  
TOTAL LOCK STAINLESS STEEL SWIVEL CASTER**

Add TL to swivel caster number

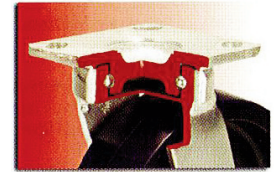

Swivel Head Section

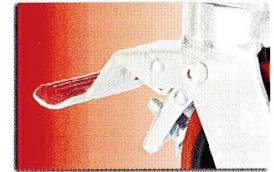

Total Lock System

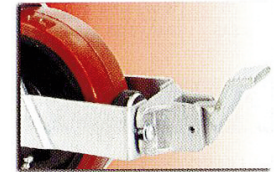

Wheel Face Break



Directional Lock

### 2,000 LBS. LOAD CAPACITY STAINLESS STEEL KINGPINLESS TYPE CASTERS

- Fabricated AISI 304 Stainless Steel Top Plate and Fork Base
- Precision CNC Machined Raceways with Kingpinless construction
- Totally Sealed Swivel Head with Grease Nipple
- 1/4" Thick Fork Legs Robotically welded Inside & Outside to 2 1/2" fork spacing
- 1/2" Wheel axle
- 4 Position Directional Lock Slots
- Finish: Bright Zinc Plated

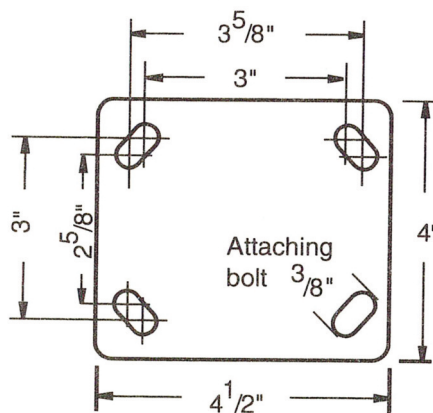

**TOP PLATE**  
4 X 4-1/2

**BOLT HOLE CENTER**  
2-5/8 X 3-5/8  
**SLOTTED TO**  
3 X 3

**ATTACHING BOLT SIZE**  
3/8

#### RIG OPTIONS

**DL: 4-WAY DIRECTIONAL LOCK**  
**WFB: WHEEL FACE BRAKE**  
ADD TO SUFFIX  
OF THE CASTER PART NUMBER

# 4

## GHKU KINGPINLESS STAINLESS STEEL TOTAL LOCK SERIES CASTERS

### NY/MD WHEELS

#### NYLACRON™ WHEELS

- Precision Machined from Cast Polyamide. Hardness 112-120 Rockwell R
- Ultimate choice for Extremely High Load applications to replace metallic wheels
- Offer very high abrasion resistance and very low rolling resistance under extreme loads

- Resistant to salt, grease, alcohol and mild acids - can be used in corrosive applications with appropriate bearings
- Stainless Steel Precision Ball Bearings
- Temperature Range: -40°F to +270°F

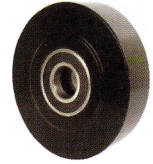

Part Number Swivel Caster	Part Number Swivel with Total Lock	Part Number Rigid Caster	Wheel Diameter (inch)	Tread Width (inch)	Load Capacity (lbs)	Overall Height (inch)	Swivel Radius (inch)	Swivel Radius w/Total Lock (inch)	Swivel Radius w/Wheel Brake (inch)
GHKUSS42SNYMD	GHKUSS42SNYMDTL	GHKUSS42RNYMD	4	2	2000	5-5/8	3-3/16	4	8-1/2
GHKUSS52SNYMD	GHKUSS52SNYMDTL	GHKUSS52RNYMD	5	2	2000	6-1/2	3-7/8	4	9-1/2
GHKUSS62SNYMD	GHKUSS62SNYMDTL	GHKUSS62RNYMD	6	2	2000	7-1/2	4-9/16	6	10
GHKUSS82SNYMD	GHKUSS82SNYMDTL	GHKUSS82RNYMD	8	2	2000	9-1/2	6	6	11-1/2

### NY/MC WHEELS

#### NYLACRON™ WHITE WHEELS

- Precision Machined from Cast Polyamide. Hardness 112-120 Rockwell R
- Ultimate choice for Extremely High Load applications to replace metallic wheels
- Offer very high abrasion resistance and very low rolling resistance under extreme loads

- Resistant to salt, grease, alcohol and mild acids - can be used in corrosive applications with appropriate bearings
- Stainless Steel Precision Ball Bearings
- Temperature Range: -40°F to +270°F



Part Number Swivel Caster	Part Number Swivel with Total Lock	Part Number Rigid Caster	Wheel Diameter (inch)	Tread Width (inch)	Load Capacity (lbs)	Overall Height (inch)	Swivel Radius (inch)	Swivel Radius w/Total Lock (inch)	Swivel Radius w/Wheel Brake (inch)
GHKUSS42SNYMC	GHKUSS42SNYMC TL	GHKUSS42RNYMC	4	2	2000	5-5/8	3-3/16	4	8-1/2
GHKUSS52SNYMC	GHKUSS52SNYMC TL	GHKUSS52RNYMC	5	2	2000	6-1/2	3-7/8	4	9-1/2
GHKUSS62SNYMC	GHKUSS62SNYMC TL	GHKUSS62RNYMC	6	2	2000	7-1/2	4-9/16	6	10
GHKUSS82SNYMC	GHKUSS82SNYMC TL	GHKUSS82RNYMC	8	2	2000	9-1/2	6	6	11-1/2

### NN WHEELS

#### NYLON WHEELS

- Injection molded from Nylon 6
- 100% washable & steam cleanable; impervious to water, highly resistant to organic solvents, most chemicals & cleaning solutions; ideal for use in food processing and packaging plants
- Offer high impact strength and exceptional abrasion resistance

- Hard tread has slight crown and rolls very easily
- Non-marking
- Durometer: 75 Shore D (+/-5)
- Stainless Steel Precision Ball Bearings
- Temperature Range: -40°F to +180°F
- Available in Anti-Static add "AS"



Part Number Swivel Caster	Part Number Swivel with Total Lock	Part Number Rigid Caster	Wheel Diameter (inch)	Tread Width (inch)	Load Capacity (lbs)	Overall Height (inch)	Swivel Radius (inch)	Swivel Radius w/Total Lock (inch)	Swivel Radius w/Wheel Brake (inch)
GHKUSS42SNN	GHKUSS42SNN TL	GHKUSS42RNN	4	2	1320	5-5/8	3-3/16	4	8-1/2
GHKUSS52SNN	GHKUSS52SNN TL	GHKUSS52RNN	5	2	1320	6-1/2	3-7/8	4	9-1/2
GHKUSS62SNN	GHKUSS62SNN TL	GHKUSS62RNN	6	2	1320	7-1/2	4-9/16	6	10
GHKUSS82SNN	GHKUSS82SNN TL	GHKUSS82RNN	8	2	2000	9-1/2	6	6	11-1/2

# 4

## GHKU KINGPINLESS STAINLESS STEEL TOTAL LOCK SERIES CASTERS

### SS WHEELS

#### STAINLESS STEEL WHEELS

- Type 304 Stainless Steel
- Non-magnetic & Non-sparking
- Excellent corrosion resistance
- Slightly crowned tread face with rounded corners
- Stainless Steel Precision Ball Bearings

- Temperature Range: 800°F

Custom Stainless Steel Wheels  
made to your specifications

V-Groove - VG

Flanged - FL



Part Number Swivel Caster	Part Number Swivel with Total Lock	Part Number Rigid Caster	Wheel Diameter (inch)	Tread Width (inch)	Load Capacity (lbs)	Overall Height (inch)	Swivel Radius (inch)	Swivel Radius w/Total Lock (inch)	Swivel Radius w/Wheel Brake (inch)
GHKUSS42SSS	GHKUSS42SSSTL	GHKUSS42RSS	4	2	1000	5-5/8	3-3/16	4	8-1/2
GHKUSS52SSS	GHKUSS52SSSTL	GHKUSS52RSS	5	2	1000	6-1/2	3-7/8	4	9-1/2
GHKUSS62SSS	GHKUSS62SSSTL	GHKUSS62RSS	6	2	1000	7-1/2	4-9/16	6	10
GHKUSS82SSS	GHKUSS82SSSTL	GHKUSS82RSS	8	2	1000	9-1/2	6	6	11-1/2

### SEN WHEELS

#### SOLID ELASTOMER WHEEL NYLON CORE

- 70 Shore (D) durometer
- FDA standards for use in food processing environments
- 100% Washable

- Stainless Steel Precision Ball Bearings
- Glass-filled nylon core insert endures heat
- High impact and abrasion resistant
- Resists oil, grease, water, and most solvents
- Temp Range: -50°F to +180°F



Part Number Swivel Caster	Part Number Swivel with Total Lock	Part Number Rigid Caster	Wheel Diameter (inch)	Tread Width (inch)	Load Capacity (lbs)	Overall Height (inch)	Swivel Radius (inch)	Swivel Radius w/Total Lock (inch)	Swivel Radius w/Wheel Brake (inch)
GHKUSS42SSEN	GHKUSS42SSENTL	GHKUSS42RSEN	4	2	1000	5-5/8	3-3/16	4	8-1/2
GHKUSS52SSEN	GHKUSS52SSENTL	GHKUSS52RSEN	5	2	1400	6-1/2	3-7/8	4	9-1/2
GHKUSS62SSEN	GHKUSS62SSENTL	GHKUSS62RSEN	6	2	1700	7-1/2	4-9/16	6	10
GHKUSS82SSEN	GHKUSS82SSENTL	GHKUSS82RSEN	8	2	2000	9-1/2	6	6	11-1/2

### KR WHEELS

#### SOLID POLYURETHANE KRYTONIC™ WHEELS

- Polyether Polyurethane has excellent carrying capacity.
- Crown shape affords an easy-rolling quiet operation
- Greater service life and resistance to chunking, cutting and abrasive wear

- 100% washable, steam cleanable, and resistant to most chemicals
- Non-marking tread
- Durometer: 58 Shore D (+/-5)
- Stainless Steel Precision Ball Bearings
- Temperature Range: + 250°F for up to a 1/2 hour.



Part Number Swivel Caster	Part Number Swivel with Total Lock	Part Number Rigid Caster	Wheel Diameter (inch)	Tread Width (inch)	Load Capacity (lbs)	Overall Height (inch)	Swivel Radius (inch)	Swivel Radius w/Total Lock (inch)	Swivel Radius w/Wheel Brake (inch)
GHKUSS42SKR	GHKUSS42SKRTL	GHKUSS42RKR	4	2	500	5-5/8	3-3/16	4	8-1/2
GHKUSS52SKR	GHKUSS52SKRTL	GHKUSS52RKR	5	2	600	6-1/2	3-7/8	4	9-1/2
GHKUSS62SKR	GHKUSS62SKRTL	GHKUSS62RKR	6	2	700	7-1/2	4-9/16	6	10
GHKUSS82SKR	GHKUSS82SKRTL	GHKUSS82RKR	8	2	800	9-1/2	6	6	11-1/2



# 4 170 SERIES KINGPINLESS CASTERS



Swivel Cross Section

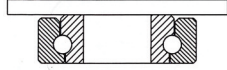

## 2,000 LBS. LOAD CAPACITY STAINLESS STEEL KINGPINLESS TYPE CASTERS

- **Top Plate:** 5/16" AISI 1045 steel welded and heat treated for longer life
- **Yoke Base:** Notched AISI 1045 steel
- **Swivel Section:** One row of 3/8" ball bearings mounted in a heat treated precision machined raceway. Zerk in swivel section
- **Fork Legs:** 1/4" steel, formed to increase strength and welded on inside and outside yoke base. Fork lift spacing 2-1/2"
- **Axle:** 1/2" diameter hollow axle with zerk fitting on roller and tapered bearing models (Solid axle on Delrin, precision ball, and Oilex models)
- **Finish:** Zinc plating
- Alternate or custom caster configurations available

Available with non-hardened raceways. Change caster number from 110 to 170.

*Stamped Steel fully heat treated construction.*

### BRAKES OPTIONS

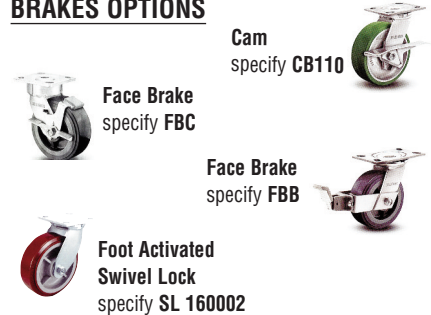

Cam  
specify **CB110**

Face Brake  
specify **FBC**

Face Brake  
specify **FBB**

Foot Activated  
Swivel Lock  
specify **SL 160002**

### TYPICAL APPLICATIONS

- Dollies
- Dough troughs
- Platform trucks
- Tow line
- Utility carts
- Tooling fixtures
- Scrap metal carriers

**ALL WHEELS  
AVAILABLE WITH  
ROLLER BEARINGS  
OR  
DELRI BUSHING**

### MOUNTING PLATE OPTIONS

#### TOP PLATE: 16 (STANDARD)

**Plate Size:** 4" x 4-1/2"  
**Bolt Holes:** 2-5/8" x 3-5/8"  
slotted to 3" x 3"  
**Bolt Size:** 3/8"

#### TOP PLATE: K

**Plate Size:** 4-1/2" x 6-1/4"  
**Bolt Holes:** 5-1/4" x 3-3/8"  
slotted to  
4-15/16" x 2-7/16"  
**Bolt Size:** 1/2"

#### TOP PLATE: D

**Plate Size:** 5" x 5-1/2"  
**Bolt Holes:** 4-1/8" x 4-1/2"  
**Bolt Size:** 3/8"

#### TOP PLATE: J

**Plate Size:** 4" x 5"  
**Bolt Holes:** 4" x 3"  
slotted to  
3-3/8" x 2-5/8"  
**Bolt Size:** 5/8"

\*Add options to end of part number

### BEARING OPTIONS

Roller Bearing (01)  
Industrial Ball (27)  
Precision Ball (28)

# 4 170 SERIES KINGPINLESS CASTERS

## X-TRA ROUND TREAD 29 PEDESTAL PRECISION XR

- Prevenz™ antimicrobial models available
- Add PREV to end of caster number
- Precision Ball Bearings

Part Number Swivel Caster	Part Number Rigid Caster	Wheel Diameter (inch)	Tread Width (inch)	Load Capacity (lbs)	Overall Height (inch)	Swivel Lead (inch)	Approx. Weight (lbs)
170XR06229S	170XR06229R	6	2	600	7-1/2	1-3/4	6-1/2
170XR08229S	170XR08229R	8	2	675	9-1/2	1-3/4	7-1/2



## EXTREME PLUS SOLID ELASTOMER XP

- Hardness: 60 Shore D
- Premium Polyurethane
- Excellent for towing applications
- Precision Ball Bearings
- Wheel Face: Moderate crown
- Temperature Range: up to +250°F

Part Number Swivel Caster	Part Number Rigid Caster	Wheel Diameter (inch)	Tread Width (inch)	Load Capacity (lbs)	Overall Height (inch)	Swivel Lead (inch)	Approx. Weight (lbs)
170XP04228S	170XP04228R	4	2	1200	6-1/2	1-5/8	5-1/2
170XP05228S	170XP05228R	5	2	1200	6-1/2	1-5/8	5-1/2
170XP06228S	170XP06228R	6	2	1200	7-1/2	1-3/4	6-1/2
170XP08228S	170XP08228R	8	2	1200	9-1/2	1-3/4	8-1/2



## X-TREME™ PLUS SOLID POLYURETHANE 29 PEDESTAL PRECISION XP

- Prevenz™ antimicrobial models available
- Add PREV to end of caster number
- Precision Ball Bearings

Part Number Swivel Caster	Part Number Rigid Caster	Wheel Diameter (inch)	Tread Width (inch)	Load Capacity (lbs)	Overall Height (inch)	Swivel Lead (inch)	Approx. Weight (lbs)
170XP04229S	170XP04229R	4	2	1250	5-5/8	1-7/16	6
170XP05229S	170XP05229R	5	2	1250	6-1/2	1-5/8	6-1/2
170XP06229S	170XP06229R	6	2	1250	7-1/2	1-7/8	7-1/4
170XP08229S	170XP08229R	8	2	1250	9-1/2	2-3/8	9



## ELASTIC BLUE RUBBER BALL BEARING ERB

- Elastic solid rubber, smooth rolling quality
- Color Blue, 65° + 3° shore A
- Vulcanized, for non-detachable bond, low rolling resistance
- Precision Ball Bearings
- Made of aluminum die-cast, corrosion-resistant, with dual sealed precision ball bearings

Part Number Swivel Caster	Part Number Rigid Caster	Wheel Diameter (inch)	Tread Width (inch)	Load Capacity (lbs)	Overall Height (inch)	Swivel Lead (inch)	Approx. Weight (lbs)
170ERB06229S	170ERB06229R	6	2	660	7-1/2	1-3/4	6-1/2
170ERB08229S	170ERB08229R	8	2	800	9-1/2	1-3/4	7-1/2



# 4 170 SERIES KINGPINLESS CASTERS

## **POLYURETHANE ON ALUMINUM ROUND TREAD 28 PRECISION BALL BEARING PM95A**

- Composed of a polyurethane elastomer open cast or injection molded, on clean, close tolerance cores
- Wheels feature a chemical and mechanical lock of tread to the core

- High capacity polyurethane protects floors
- Non-marking
- Delivers quieter operation than standard metal wheels

Part Number Swivel Caster	Part Number Rigid Caster	Wheel Diameter (inch)	Tread Width (inch)	Load Capacity (lbs)	Overall Height (inch)	Swivel Lead (inch)	Approx. Weight (lbs)
170PM05228S	170PM05228R	5	2	1000	6-1/2	1-3/8	6
170PM06228S	170PM06228R	6	2	1250	7-1/2	1-9/16	7
170PM08228S	170PM08228R	8	2	1500	10-1/8	2-1/4	9



## **POLYURETHANE ON POLYPROPYLENE 29 PEDESTAL PRECISION PM80A**

- Prevenz™ antimicrobial models available
- Add PREV to end of caster number

- Precision Ball 28 and annular ball 31 bearings available
- Change “29” to other breaking code

Part Number Swivel Caster	Part Number Rigid Caster	Wheel Diameter (inch)	Tread Width (inch)	Load Capacity (lbs)	Overall Height (inch)	Swivel Lead (inch)	Approx. Weight (lbs)
170PM0622880AS	170PM0622880AR	6	2	900	7-1/2	1-7/8	6-1/2
170PM0822880AS	170PM0822880AR	8	2	1000	9-1/2	2-3/8	8-1/2



## **MAXIM® 29 PEDESTAL PRECISION NG**

- Prevenz™ antimicrobial models available
- Add PREV to end of caster number

- Precision Pedestal Bearing
- Change “29” to other breaking code

Part Number Swivel Caster	Part Number Rigid Caster	Wheel Diameter (inch)	Tread Width (inch)	Load Capacity (lbs)	Overall Height (inch)	Swivel Lead (inch)	Approx. Weight (lbs)
170NG04229S	170NG04229R	4	2	800	5-5/8	1-7/16	6
170NG05229S	170NG05229R	5	2	1000	6-1/2	1-5/8	6-1/2
170NG06229S	170NG06229R	6	2	1200	7-1/2	1-7/8	7-1/4
170NG08229S	170NG08229R	8	2	1400	9-1/2	2-3/8	9



## **URETHANE ON BLACK NYLON 28 PRECISION BALL BEARING XG**

- Offers greater load capacity than rubber
- Resists chemicals, acids, caustic, and oils
- Precision Ball Bearings

- Excellent for use in applications where ergonomic floor protective wheels are needed

Part Number Swivel Caster	Part Number Rigid Caster	Wheel Diameter (inch)	Tread Width (inch)	Load Capacity (lbs)	Overall Height (inch)	Swivel Lead (inch)	Approx. Weight (lbs)
110XG06228S	110XG06228R	6	2	900	7-1/2	1-9/16	7-1/4
110XG08228S	110XG08228R	8	2	900	10-1/8	2-1/4	9

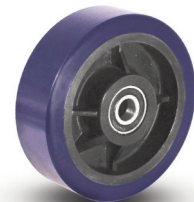

# 4 170 SERIES KINGPINLESS CASTERS

## HEAVY DUTY REINFORCED THERMOPLASTIC 28 PRECISION BALL BEARING DT

- Creates a stronger and higher impact resistant wheel
- Glass reinforced nylon material
- Precision Ball Bearings
- Ideal for applications subject to strong impact and abuse

Part Number Swivel Caster	Part Number Rigid Caster	Wheel Diameter (inch)	Tread Width (inch)	Load Capacity (lbs)	Overall Height (inch)	Swivel Lead (inch)	Approx. Weight (lbs)
170DT04228S	170DT04228R	4	2	1000	5-5/8	1-3/16	6
170DT05228S	170DT05228R	5	2	1200	6-1/2	1-3/8	6-1/2
170DT06228S	170DT06228R	6	2	1400	7-1/2	1-9/16	7-1/4
170DT08228S	170DT08228R	8	2	1600	10-1/8	2-1/4	9

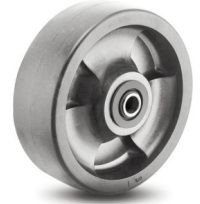

## POLYURETHANE ON CAST IRON 28 PRECISION BALL BEARING PY95A

- Chemically bonded to a cast iron core
- High capacity polyurethane protects floors
- Non-marking
- Precision Ball Bearings
- Delivers quieter operation than standard metal wheels

Part Number Swivel Caster	Part Number Rigid Caster	Wheel Diameter (inch)	Tread Width (inch)	Load Capacity (lbs)	Overall Height (inch)	Swivel Lead (inch)	Approx. Weight (lbs)
170PY06228S	170PY06228R	6	2	1230	6-1/2	1-3/8	6
170PY08228S	170PY08228R	8	2	1500	7-1/2	1-9/16	7
170PY10228S	170PY10228R	10	2	1700	10-1/8	2-1/4	9



## ETHANE POLYURETHANE ON CAST IRON 28 PRECISION BALL BEARING PY80A

- Chemically bonded to a cast iron core
- High capacity polyurethane protects floors
- Non-marking
- Precision Ball Bearings
- Delivers quieter operation than standard metal wheels
- Rejects metal chips, debris and other items that can be harmful to the wheel

Part Number Swivel Caster	Part Number Rigid Caster	Wheel Diameter (inch)	Tread Width (inch)	Load Capacity (lbs)	Overall Height (inch)	Swivel Lead (inch)	Approx. Weight (lbs)
170PY0622880AS	170PY0622880AR	6	2	1025	6-1/2	1-3/8	6
170PY0822880AS	170PY0822880AR	8	2	1250	7-1/2	1-9/16	7
170PY1022880AS	170PY1022880AR	10	2	1400	10-1/8	2-1/4	9



## NEOPRENE ON ALUMINUM 28 PRECISION BALL BEARING NP

- Very high resilience and is impervious to metal chips and screws
- Performs well in contact with oils and chemicals and can be used over a wide temperature range
- Precision Ball Bearings
- Designed to handle heavy loads
- High chemical resistance

Part Number Swivel Caster	Part Number Rigid Caster	Wheel Diameter (inch)	Tread Width (inch)	Load Capacity (lbs)	Overall Height (inch)	Swivel Lead (inch)	Approx. Weight (lbs)
170NP05228S	170NP05228R	5	2	600	6-1/2	1-3/8	6
170NP06228S	170NP06228R	6	2	700	7-1/2	1-9/16	7
170NP08228S	170NP08228R	8	2	700	10-1/8	2-1/4	9



# 4 170 SERIES KINGPINLESS CASTERS

## NY/MD WHEELS

### NYLACRON™ WHEELS

- Precision Machined from Cast Polyamide. Hardness 112-120 Rockwell R
- Ultimate choice for Extremely High Load applications to replace metallic wheels
- Offer very high abrasion resistance and very low rolling resistance under extreme loads

- Resistant to salt, grease, alcohol and mild acids - can be used in corrosive applications with appropriate bearings
- Stainless Steel Precision Ball Bearings
- Temperature Range: -40°F to +270°F

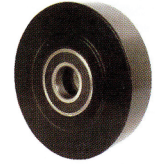

Part Number Swivel Caster	Part Number Swivel with Total Lock	Part Number Rigid Caster	Wheel Diameter (inch)	Tread Width (inch)	Load Capacity (lbs)	Overall Height (inch)	Swivel Radius (inch)	Swivel Radius w/Total Lock (inch)	Swivel Radius w/Wheel Brake (inch)
17042SNYMD	17042SNYMDTL	17042RNYMD	4	2	2000	5-5/8	3-3/16	4	8-1/2
17052SNYMD	17052SNYMDTL	17052RNYMD	5	2	2000	6-1/2	3-7/8	4	9-1/2
17062SNYMD	17062SNYMDTL	17062RNYMD	6	2	2000	7-1/2	4-9/16	6	10
17082SNYMD	17082SNYMDTL	17082RNYMD	8	2	2000	9-1/2	6	6	11-1/2

## NY/MC WHEELS

### NYLACRON™ WHITE WHEELS

- Precision Machined from Cast Polyamide. Hardness 112-120 Rockwell R
- Ultimate choice for Extremely High Load applications to replace metallic wheels
- Offer very high abrasion resistance and very low rolling resistance under extreme loads

- Resistant to salt, grease, alcohol and mild acids - can be used in corrosive applications with appropriate bearings
- Stainless Steel Precision Ball Bearings
- Temperature Range: -40°F to +270°F



Part Number Swivel Caster	Part Number Swivel with Total Lock	Part Number Rigid Caster	Wheel Diameter (inch)	Tread Width (inch)	Load Capacity (lbs)	Overall Height (inch)	Swivel Radius (inch)	Swivel Radius w/Total Lock (inch)	Swivel Radius w/Wheel Brake (inch)
17042SNYMC	17042SNYMCTL	17042RNYMC	4	2	2000	5-5/8	3-3/16	4	8-1/2
17052SNYMC	17052SNYMCTL	17052RNYMC	5	2	2000	6-1/2	3-7/8	4	9-1/2
17062SNYMC	17062SNYMCTL	17062RNYMC	6	2	2000	7-1/2	4-9/16	6	10
17082SNYMC	17082SNYMCTL	17082RNYMC	8	2	2000	9-1/2	6	6	11-1/2

## KR WHEELS

### SOLID POLYURETHANE KRYTONIC™ WHEELS

- Polyether Polyurethane has excellent carrying capacity.
- Crown shape affords an easy-rolling quiet operation
- Greater service life and resistance to chunking, cutting and abrasive wear

- 100% washable, steam cleanable, and resistant to most chemicals
- Non-marking tread
- Durometer: 58 Shore D (+/-5)
- Stainless Steel Precision Ball Bearings
- Temperature Range: + 250°F for up a 1/2 hour.

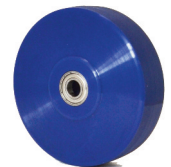

Part Number Swivel Caster	Part Number Swivel with Total Lock	Part Number Rigid Caster	Wheel Diameter (inch)	Tread Width (inch)	Load Capacity (lbs)	Overall Height (inch)	Swivel Radius (inch)	Swivel Radius w/Total Lock (inch)	Swivel Radius w/Wheel Brake (inch)
17042SKR	17042SKRTL	17042RKR	4	2	500	5-5/8	3-3/16	4	8-1/2
17052SKR	17052SKRTL	17052RKR	5	2	600	6-1/2	3-7/8	4	9-1/2
17062SKR	17062SKRTL	17062RKR	6	2	700	7-1/2	4-9/16	6	10
17082SKR	17082SKRTL	17082RKR	8	2	800	9-1/2	6	6	11-1/2

# 4 170 SERIES KINGPINLESS CASTERS

## SWE 80A FLAT TREAD WHEELS

### SWIVEL-EAZ™ INTEGRATED TWIN WHEELS

- Reduces rolling resistance
- Minimizes initial start forces
- Prolongs the life of the swivel caster
- Eliminates the need for costly dual-wheel caster

- Carries 2x the load of standard size wheels with similar tread hardness
- Maintenance-free for longer life
- Non-marking, high-performance elastomer treads
- Patented SWE® Precision Ball Bearing Design
- Temp Range: -40°F to +180°F



Part Number Swivel Caster	Part Number Rigid Caster	Wheel Diameter (inch)	Tread Width (inch)	Load Capacity (lbs)	Overall Height (inch)	Swivel Radius (inch)	Swivel Radius w/Wheel Brake (inch)
17032SSWE80AFT	17032RSWE80AFT	3	2	560	5-1/16	3-3/16	8-1/2
17042SSWE80AFT	17042RSWE80AFT	4	2	700	5-5/8	3-3/16	8-1/2
17052SSWE80AFT	17052RSWE80AFT	5	2	1050	6-1/2	3-7/8	9-1/2
17062SSWE80AFT	17062RSWE80AFT	6	2	1400	7-1/2	4-9/16	10
17082SSWE80AFT	17082RSWE80AFT	8	2	1400	9-1/2	6	11-1/2

## SWE 80A CROWN TREAD WHEELS

### SWIVEL-EAZ™ INTEGRATED TWIN WHEELS

- Reduces rolling resistance
- Minimizes initial start forces
- Prolongs the life of the swivel caster
- Eliminates the need for costly dual-wheel caster

- Carries 2x the load of standard size wheels with similar tread hardness
- Maintenance-free for longer life
- Non-marking, high-performance elastomer treads
- Patented SWE® Precision Ball Bearing Design
- Temp Range: -40°F to +180°F



Part Number Swivel Caster	Part Number Rigid Caster	Wheel Diameter (inch)	Tread Width (inch)	Load Capacity (lbs)	Overall Height (inch)	Swivel Radius (inch)	Swivel Radius w/Wheel Brake (inch)
17032SSWE80ACRN	17032RSWE80ACRN	3	2	320	5-1/16	3-3/16	8-1/2
17042SSWE80ACRN	17042RSWE80ACRN	4	2	400	5-5/8	3-3/16	8-1/2
17052SSWE80ACRN	17052RSWE80ACRN	5	2	650	6-1/2	3-7/8	9-1/2
17062SSWE80ACRN	17062RSWE80ACRN	6	2	900	7-1/2	4-9/16	10
17082SSWE80ACRN	17082RSWE80ACRN	8	2	1400	9-1/2	6	11-1/2

## SWE 95A FLAT TREAD WHEELS

### SWIVEL-EAZ™ INTEGRATED TWIN WHEELS

- Reduces rolling resistance
- Minimizes initial start forces
- Prolongs the life of the swivel caster
- Eliminates the need for costly dual-wheel caster

- Carries 2x the load of standard size wheels with similar tread hardness
- Maintenance-free for longer life
- Non-marking, high-performance elastomer treads
- Patented SWE® Precision Ball Bearing Design
- Temp Range: -40°F to +180°F



Part Number Swivel Caster	Part Number Rigid Caster	Wheel Diameter (inch)	Tread Width (inch)	Load Capacity (lbs)	Overall Height (inch)	Swivel Radius (inch)	Swivel Radius w/Wheel Brake (inch)
17032SSWE95AFT	17032RSWE95AFT	3	2	720	5-1/16	3-3/16	8-1/2
17042SSWE95AFT	17042RSWE95AFT	4	2	900	5-5/8	3-3/16	8-1/2
17052SSWE95AFT	17052RSWE95AFT	5	2	1400	6-1/2	3-7/8	9-1/2
17062SSWE95AFT	17062RSWE95AFT	6	2	1400	7-1/2	4-9/16	10
17082SSWE95AFT	17082RSWE95AFT	8	2	1400	9-1/2	6	11-1/2

Also available in crown and flat tread 70A, 60D and 75D

# 4 170 SERIES KINGPINLESS CASTERS

## SWE 95A CROWN TREAD WHEELS

### SWIVEL-EAZ™ INTEGRATED TWIN WHEELS

- Reduces rolling resistance
- Minimizes initial start forces
- Prolongs the life of the swivel caster
- Eliminates the need for costly dual-wheel caster

- Carries 2x the load of standard size wheels with similar tread hardness
- Maintenance-free for longer life
- Non-marking, high-performance elastomer treads
- Patented SWE® Precision Ball Bearing Design
- Temp Range: -40°F to +180°F



Part Number Swivel Caster	Part Number Rigid Caster	Wheel Diameter (inch)	Tread Width (inch)	Load Capacity (lbs)	Overall Height (inch)	Swivel Radius (inch)	Swivel Radius w/Wheel Brake (inch)
17032SSWE95ACRN	17032RSWE95ACRN	3	2	400	5-1/16	3-3/16	8-1/2
17042SSWE95ACRN	17042RSWE95ACRN	4	2	500	5-5/8	3-3/16	8-1/2
17052SSWE95ACRN	17052RSWE95ACRN	5	2	800	6-1/2	3-7/8	9-1/2
17062SSWE95ACRN	17062RSWE95ACRN	6	2	1100	7-1/2	4-9/16	10
17082SSWE95ACRN	17082RSWE95ACRN	8	2	1400	9-1/2	6	11-1/2

## SWE 70D FLAT TREAD WHEELS

### SWIVEL-EAZ™ INTEGRATED TWIN WHEELS

- Reduces rolling resistance
- Minimizes initial start forces
- Prolongs the life of the swivel caster
- Eliminates the need for costly dual-wheel caster

- Carries 2x the load of standard size wheels with similar tread hardness
- Maintenance-free for longer life
- Non-marking, high-performance elastomer treads
- Patented SWE® Precision Ball Bearing Design
- Temp Range: -40°F to +180°F



Part Number Swivel Caster	Part Number Rigid Caster	Wheel Diameter (inch)	Tread Width (inch)	Load Capacity (lbs)	Overall Height (inch)	Swivel Radius (inch)	Swivel Radius w/Wheel Brake (inch)
17032SSWE70ACRN	17032RSWE70ACRN	3	2	800	5-1/16	3-3/16	8-1/2
17042SSWE70ACRN	17042RSWE70ACRN	4	2	1000	5-5/8	3-3/16	8-1/2
17052SSWE70ACRN	17052RSWE70ACRN	5	2	1400	6-1/2	3-7/8	9-1/2
17062SSWE70ACRN	17062RSWE70ACRN	6	2	1400	7-1/2	4-9/16	10
17082SSWE70ACRN	17082RSWE70ACRN	8	2	1400	9-1/2	6	11-1/2

## SWE 70D CROWN TREAD WHEELS

### SWIVEL-EAZ™ INTEGRATED TWIN WHEELS

- Reduces rolling resistance
- Minimizes initial start forces
- Prolongs the life of the swivel caster
- Eliminates the need for costly dual-wheel caster

- Carries 2x the load of standard size wheels with similar tread hardness
- Maintenance-free for longer life
- Non-marking, high-performance elastomer treads
- Patented SWE® Precision Ball Bearing Design
- Temp Range: -40°F to +180°F



Part Number Swivel Caster	Part Number Rigid Caster	Wheel Diameter (inch)	Tread Width (inch)	Load Capacity (lbs)	Overall Height (inch)	Swivel Radius (inch)	Swivel Radius w/Wheel Brake (inch)
17032SSWE70ACRN	17032RSWE70ACRN	3	2	520	5-1/16	3-3/16	8-1/2
17042SSWE70ACRN	17042RSWE70ACRN	4	2	800	5-5/8	3-3/16	8-1/2
17052SSWE70ACRN	17052RSWE70ACRN	5	2	1060	6-1/2	3-7/8	9-1/2
17062SSWE70ACRN	17062RSWE70ACRN	6	2	1300	7-1/2	4-9/16	10
17082SSWE70ACRN	17082RSWE70ACRN	8	2	1400	9-1/2	6	11-1/2

\*When ordering, note durometer after the part number (ex: SWE-320-FT-60D)  
Also available in crown and flat tread 70A, 60D and 75D

# 4

## 40 SERIES HYBRID HEAVY DUTY KINGPIN CASTERS

3/4" Hardened kingpin bolt & nut

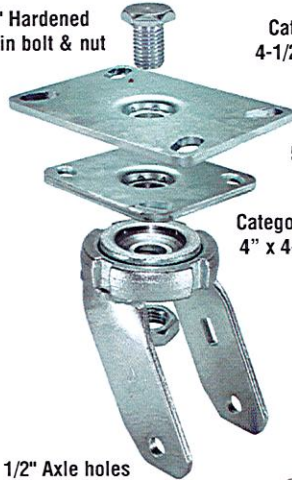

Category 5 Top Plate  
4-1/2" x 6-1/4" (shown)  
40-04

Also available in  
5" x 5-1/2" (not shown)  
40-05

Category 4 Top Plate  
4" x 4-1/2" (shown)  
40-03

1/2" Axle holes



HYBRID 8" SWIVEL CASTER



**TOP LOCK**  
TS



**CAM LOCK**  
MS



**4 POSITION LOCK**  
PS



**FOOT OPERATED SWIVEL LOCK**  
only available in  
4" x 4-1/2" top plate

### 2,000 LBS. LOAD CAPACITY FORGED HYBRID KINGPIN CASTERS

- Kingpinless strength with Kingpin simplicity
- Kingpinless style drop forged swivel raceway  
3/8" Ball bearings (HRC45 steel)
- 3/4" Kingpin/Nut hardened
- 1/4" Cold forged top plate (ASTM 1045)
- 1/2" Axle holes
- Long life of caster with low cost
- Extra high endurance in distance traveled
- Hub length 2 1/2"

**ALL WHEELS AVAILABLE  
WITH PRECISION BEARINGS  
OR ROLLER BEARINGS**

**Caster Options:** 304 Stainless Steel - "S" prefix

**Other Options:** Zerk axle - "Z" suffix

**Plate size:** 4" x 4 1/2"

**Bolt Diameter:** 3/8"

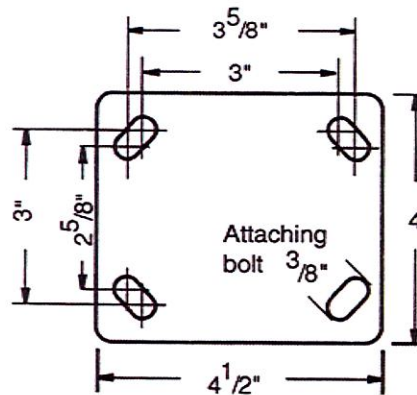

**STANDARD  
46 03 TOP PLATE  
4 X 4-1/2**

**BOLT HOLE CENTER  
2-5/8 X 3-5/8  
SLOTTED TO  
3 X 3**

**ATTACHING BOLT SIZE  
3/8**



## 4

## 40 SERIES HYBRID HEAVY DUTY KINGPIN CASTERS

MU  
WHEELS

## POLYURETHANE ON GLASS-FILLED NYLON

- 10mm blue tread
- 90-95 Durometer Shore (A) (Green Thread)
- 60-70 Durometer Shore (D)
- Light weight reinforced glass-filled nylon core

- Non-marking, non-staining, non-conductive tread
- Floor protective
- Resists oil, grease, water, and most solvents
- Temp Range: -45°F to +180°F



Part Number Swivel Caster	Part Number Rigid Caster	Wheel Diameter (inch)	Tread Width (inch)	Load Capacity (lbs)	Overall Height (inch)	Swivel Radius (inch)	Precision Bearing
40CS420MU63	40CR420MU63	4	2	800	5-5/8	3-1/8	63
40CS520MU63	40CR520MU63	5	2	1400	6-1/2	3-3/4	63
40CS620MU63	40CR620MU63	6	2	1400	7-1/2	4-1/2	63
40CS820MU63	40CR820MU63	8	2	1800	9-1/2	6-5/16	63

PTU  
WHEELS

## POLYURETHANE ON POLYOLEFIN

- 90-95 Durometer Shore (A) Ductile Polyurethane tread mechanically bonded to Polyolefin core
- High capacity and lightweight
- Resists oil, grease, water, and most solvents

- Smooth rolling and quiet
- Temp Range: -45°F to +180°F

## Options

- Donut Tread PTU (6", 8") DTU



Part Number Swivel Caster	Part Number Rigid Caster	Wheel Diameter (inch)	Tread Width (inch)	Load Capacity (lbs)	Overall Height (inch)	Swivel Radius (inch)	Precision Bearing
40CS420PTU38	40CR420PTU38	4	2	700	5-5/8	3-1/8	38
40CS520PTU38	40CR520PTU38	5	2	1000	6-1/2	3-3/4	38
40CS620PTU38	40CR620PTU38	6	2	1200	7-1/2	4-1/2	38
40CS820PTU38	40CR820PTU38	8	2	1400	9-1/2	6-5/16	38

SEN  
WHEELS

## SOLID ELASTOMER WHEEL NYLON CORE

- 70 Shore (D) durometer
- FDA standards for use in food processing environments
- 100% Washable

- Glass-filled nylon core insert endures heat
- High impact and abrasion resistant
- Resists oil, grease, water, and most solvents
- Temp Range: -50°F to +180°F



Part Number Swivel Caster	Part Number Rigid Caster	Wheel Diameter (inch)	Tread Width (inch)	Load Capacity (lbs)	Overall Height (inch)	Swivel Radius (inch)	Precision Bearing
40CS420SEN63	40CR420SEN63	4	2	1500	5-5/8	3-1/8	63
40CS520SEN63	40CR520SEN63	5	2	1800	6-1/2	3-3/4	63
40CS620SEN63	40CR620SEN63	6	2	2100	7-1/2	4-1/2	63
40CS820SEN63	40CR820SEN63	8	2	2600	9-1/2	6-5/16	63

DS  
WHEELS

## DUCTILE STEEL

- Extreme heavy duty applications
- High capacity

- Effortless rolling under heavy loads
- Temp Range: -45°F to +800°F



Part Number Swivel Caster	Part Number Rigid Caster	Wheel Diameter (inch)	Tread Width (inch)	Load Capacity (lbs)	Overall Height (inch)	Swivel Radius (inch)	Precision Bearing
40CS420DS38	40CR420DS38	4	2	1200	5-5/8	3-1/8	38
40CS520DS38	40CR520DS38	5	2	1500	6-1/2	3-3/4	38
40CS620DS38	40CR620DS38	6	2	2000	7-1/2	4-1/2	38
40CS820DS38	40CR820DS38	8	2	2500	9-1/2	6-5/16	38

## 4

## 40 SERIES HYBRID HEAVY DUTY KINGPIN CASTERS

SPU  
WHEELS

## SOLID POLYURETHANE

- 60 Durometer Shore (D)
- FDA requirements met for use in food processing environments
- 100% Washable

- One piece mold design eliminates bonding failure
- High impact and abrasion resistant
- Resists oil, grease, water, and most solvents
- Temp Range: -45°F to +180°F



Part Number Swivel Caster	Part Number Rigid Caster	Wheel Diameter (inch)	Tread Width (inch)	Load Capacity (lbs)	Overall Height (inch)	Swivel Radius (inch)	Precision Bearing
40CS420SPU63	40CR420SPU63	4	2	700	5-5/8	3-1/8	63
40CS520SPU63	40CR520SPU63	5	2	1200	6-1/2	3-3/4	63
40CS620SPU63	40CR620SPU63	6	2	1200	7-1/2	4-1/2	63
40CS820SPU63	40CR820SPU63	8	2	1400	9-1/2	6-5/16	63

ERN  
WHEELS

## ELASTIC RUBBER ON NYLON

- 70-75 Durometer Shore (A)
- Elastic rubber molded to nylon core

- Non-marking
- Easy rolling, impact resistant and shock absorbing
- Temp Range: -40°F to +160°F



Part Number Swivel Caster	Part Number Rigid Caster	Wheel Diameter (inch)	Tread Width (inch)	Load Capacity (lbs)	Overall Height (inch)	Swivel Radius (inch)	Precision Bearing
40CS420ERN38	40CR420ERN38	4	2	325	5-5/8	3-1/8	38
40CS520ERN38	40CR520ERN38	5	2	475	6-1/2	3-3/4	38
40CS620ERN38	40CR620ERN38	6	2	500	7-1/2	4-1/2	38
40CS820ERN38	40CR820ERN38	8	2	600	9-1/2	6-5/16	38

NY/MD  
WHEELS

## NYLACRON™ WHEELS

- Precision Machined from Cast Polyamide. Hardness 112-120 Rockwell R
- Ultimate choice for Extremely High Load applications to replace metallic wheels
- Offer very high abrasion resistance and very low rolling resistance under extreme loads

- Resistant to salt, grease, alcohol and mild acids - can be used in corrosive applications with appropriate bearings
- Precision Ball Bearings
- Temperature Range: -40°F to +270°F

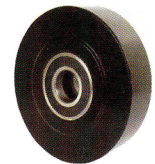

Part Number Swivel Caster	Part Number Rigid Caster	Wheel Diameter (inch)	Tread Width (inch)	Load Capacity (lbs)	Overall Height (inch)	Swivel Radius (inch)	Precision Bearing
40CS420NYMD	40CR420NYMD	4	2	2000	5-5/8	3-3/16	38
40CS520NYMD	40CR520NYMD	5	2	2000	6-1/2	3-7/8	38
40CS620NYMD	40CR620NYMD	6	2	2000	7-1/2	4-9/16	38
40CS820NYMD	40CR820NYMD	8	2	2000	9-1/2	6	38

## 4

## 40 SERIES HYBRID HEAVY DUTY KINGPIN CASTERS

TUA  
WHEELS

## POLYURETHANE ON ALUMINUM FLAT TREAD

- High Tech grade polyurethane tread
- 85 Durometer Shore (A) deflects debris
- Non-marking and rolls effortlessly
- Multi-year tread durability
- Temp Range: -40°F to +180°F

Part Number Swivel Caster	Part Number Rigid Caster	Wheel Diameter (inch)	Tread Width (inch)	Load Capacity (lbs)	Overall Height (inch)	Swivel Radius (inch)	Precision Bearing
40CS620TUA63	40CR620TUA63	6	2	1500	7-1/2	4-1/2	63
40CS820TUA63	40CR820TUA63	8	2	2000	9-1/2	6-5/16	63
40CS820TUA64	40CR820TUA64	8	2	2000	9-1/2	6-5/16	64

DUA  
WHEELS

## POLYURETHANE ON ALUMINUM DONUT TREAD

- High Tech grade polyurethane tread
- 85 Durometer Shore (A) deflects debris
- Non-marking and rolls effortlessly
- Multi-year tread durability
- Temp Range: -40°F to +180°F

Part Number Swivel Caster	Part Number Rigid Caster	Wheel Diameter (inch)	Tread Width (inch)	Load Capacity (lbs)	Overall Height (inch)	Swivel Radius (inch)	Precision Bearing
40CS420DUA63	40CR420DUA63	4	2	1000	5-5/8	3-1/8	63
40CS520DUA63	40CR520DUA63	5	2	1200	6-1/2	3-3/4	63
40CS620DUA63	40CR620DUA63	6	2	1500	7-1/2	4-1/2	63
40CS820DUA63	40CR820DUA63	8	2	2000	9-1/2	6-5/16	63

NG  
WHEELS

## NYLON GLASS-FILLED

- 85 Durometer Shore (A)
- Impervious to most chemicals, solvents, oil, salt, alkalines and water
- Use metal only bearing components for temperatures over 180°F
- Hi Temp: +490°F continuous, +550°F intermittent (part # TMA)

Part Number Swivel Caster	Part Number Rigid Caster	Wheel Diameter (inch)	Tread Width (inch)	Load Capacity (lbs)	Overall Height (inch)	Swivel Radius (inch)	Precision Bearing
40CS420NG38	40CR420NG38	4	2	800	5-5/8	3-1/8	38
40CS520NG38	40CR520NG38	5	2	1000	6-1/2	3-3/4	38
40CS620NG38	40CR620NG38	6	2	1200	7-1/2	4-1/2	38
40CS820NG38	40CR820NG38	8	2	1400	9-1/2	6-5/16	38

PPU  
WHEELS

## POLYURETHANE ON POLYOLEFIN

- Injection Molded Polyurethane Tread mechanically bonded to polyolefin core
- 90-95 Durometer Shore (A) Polyurethane Tread mechanically bonded to polyolefin core
- High capacity and lightweight
- Resist oil, grease, water and most solvents
- Smooth rolling and quiet
- Non-marking
- Temp Range: -45°F to +180°F

Part Number Swivel Caster	Part Number Rigid Caster	Wheel Diameter (inch)	Tread Width (inch)	Load Capacity (lbs)	Overall Height (inch)	Swivel Radius (inch)	Precision Bearing
40CS420PPU38	40CR420PPU38	4	2	700	5-5/8	3-1/8	38
40CS520PPU38	40CR520PPU38	5	2	750	6-1/2	3-3/4	38
40CS620PPU38	40CR620PPU38	6	2	900	7-1/2	4-1/2	38
40CS820PPU38	40CR820PPU38	8	2	1000	9-1/2	6-5/16	38



# 4 27/FT/28 SERIES KINGPIN CASTERS



**FOOT OPERATED  
FLOOR LOCK  
4PSL27**

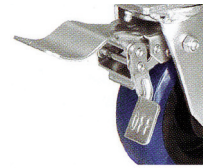

**DUAL PEDAL  
TOTAL LOCK  
DT**

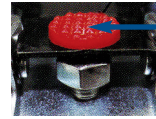

**FRONT DUAL PEDAL  
ADJUSTABLE TOTAL  
LOCKING CASTERS  
FT**

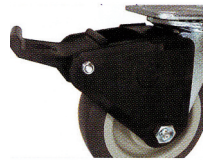

**TECH-LOCK  
PEDAL BRAKE  
H**

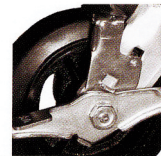

**TOP-LOCK  
BRAKE  
T**



**RACEWAY SEALS  
Thermo - plastic  
up to 140° F  
L**

## 1,250 LBS. LOAD CAPACITY FORGED KINGPIN TYPE CASTERS

- Double ball raceway offer smooth swiveling action, strength and long service life.
- Standard 5/8" nut & bolt kingpin
- 1/4" thick cold rolled steel; designed, formed and welded for optimal mobility.
- Zinc plated finish is attractive & corrosion resistant.
- Zerk grease fitting in raceway & axle for maintenance.

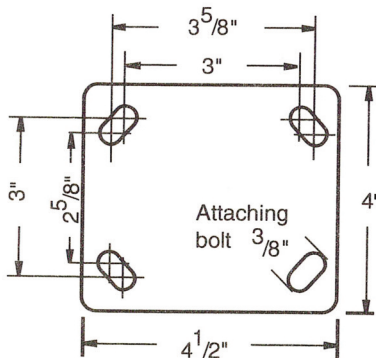

**STANDARD TOP PLATE  
4 X 4-1/2**

**BOLT HOLE CENTER  
2-5/8 X 3-5/8  
SLOTTED TO 3 X 3**

**ATTACHING BOLT SIZE  
3/8**

**OPTIONAL TOP PLATE 20  
5 X 5-1/2**

**BOLT HOLE CENTER  
4-1/8 X 4-1/2**

**ATTACHING BOLT SIZE  
3/8**

**ALL WHEELS  
AVAILABLE WITH  
PRECISION  
BALL BEARINGS  
STANDARD**

# 4 27/FT/28 SERIES KINGPIN CASTERS

## MU WHEELS POLYURETHANE ON GLASS-FILLED NYLON

- Polyurethane elastomer tread chemically bonded to an ultra-strong
- Offers a smooth effortless ride, is non-marking and protects floors.
- Resist compression set or “flat spotting,” has exceptional impact strength and good abrasion resistance

- Non-metal materials will not rust
- Color: green
- Durometer: 95 Shore A +/-5
- Temp Range: -45°F to +180°F



Part Number Swivel Caster	Part Number Swivel with Total Lock	Part Number Rigid Caster	Wheel Diameter (inch)	Tread Width (inch)	Load Capacity (lbs)	Overall Height (inch)	Swivel Radius (inch)	Swivel Radius w/Total Lock (inch)	Swivel Radius w/Wheel Brake (inch)
27MU40JN63	FTMU40JN63	28MU40JN63	4	2	700	5-5/8	3-3/16	4	8-1/2
27MU50JN63	FTMU50JN63	28MU50JN63	5	2	1000	6-1/2	3-7/8	4	9-1/2
27MU60JN63	FTMU60JN63	28MU60JN63	6	2	1200	7-1/2	4-9/16	6	10
27MU80JN63	FTMU80JN63	28MU80JN63	8	2	1400	9-1/2	6	6	11-1/2

## PM WHEELS POLYURETHANE ON POLYOLEFIN

- High performance UV resistant, liquid cast polyurethane elastomer; mechanically locked onto an injection molded polyolefin core; takes more abuse and has a longer service life than standard PP wheels
- 1-1/4" wide wheels are maroon or gray, with sanitary style (no thread guards) dished out core and dual row annular ball bearings, offering improved mobility and stability

- Axle can be completely tightened without binding the bearings. 2" wide wheels have a dark gray tread on a grey core
- Durometer: 60 Shore D +/-5
- Temp Range: -45°F to +180°F



### Optional

No seam style available (for upcharge): No seam on the wheel tread reduces the possibility of leaving indentations of soft floors (wood, linoleum, etc)

Part Number Swivel Caster	Part Number Swivel with Total Lock	Part Number Rigid Caster	Wheel Diameter (inch)	Tread Width (inch)	Load Capacity (lbs)	Overall Height (inch)	Swivel Radius (inch)	Swivel Radius w/Total Lock (inch)	Swivel Radius w/Wheel Brake (inch)
27PM40JI63	FTPM40JI63	28PM40JI63	4	2	600	5-5/8	3-3/16	4	8-1/2
27PM50JI63	FTPM50JI63	28PM50JI63	5	2	750	6-1/2	3-7/8	4	9-1/2
27PM60JI63	FTPM60JI63	28PM60JI63	6	2	900	7-1/2	4-9/16	6	10
27PM80JI63	FTPM80JI63	28PM80JI63	8	2	1000	9-1/2	6	6	11-1/2

## HU WHEELS HEAVY DUTY SOLID ELASTOMER WHEEL

- Super strength solid cast polyurethane elastomer one piece design with mechanically locked glass filled nylon bearing collar, offers the best durability and performance of any elastomer type wheel on the market
- Precision Ball Bearings
- 100% washable, steam cleanable, chemical resistant

- Extreme impact strength and abrasion and compression resistance, will not flat spot when used within capacity rating
- Offers a smooth ergonomic ride; easy start up
- Color: grey with black core/bearing collar
- Durometer: 68 Shore D +/-5
- Temp Range: -50°F to +180°F



Part Number Swivel Caster	Part Number Swivel with Total Lock	Part Number Rigid Caster	Wheel Diameter (inch)	Tread Width (inch)	Load Capacity (lbs)	Overall Height (inch)	Swivel Radius (inch)	Swivel Radius w/Total Lock (inch)	Swivel Radius w/Wheel Brake (inch)
27HU40JI63	FTHU40JI63	28HU40JI63	4	2	1000	5-5/8	3-3/16	4	8-1/2
27HU50JI63	FTHU50JI63	28HU50JI63	5	2	1400	6-1/2	3-7/8	4	9-1/2
27HU60JI63	FTHU60JI63	28HU60JI63	6	2	1700	7-1/2	4-9/16	6	10
27HU80JI63	FTHU80JI63	28HU80JI63	8	2	2000	9-1/2	6	6	11-1/2

**SU  
WHEELS****SOLID POLYURETHANE**

- Solid cast polyurethane elastomer one piece design eliminates bonding failures and is a very reliable and durable wheel
- 100% washable & steam cleanable; not affected by grease, oils, most chemicals & cleaning solutions, brine and blood
- Flanged Precision Ball Bearings

- Offers a smooth effortless ride, is non-marking and protects floors
- Resists compression set or “flat spotting,” has exceptional impact strength and is highly abrasion resistant
- Color: blue
- Durometer: 60 Shore D +/-5
- Temp Range: -50°F to +180°F



Part Number Swivel Caster	Part Number Swivel with Total Lock	Part Number Rigid Caster	Wheel Diameter (inch)	Tread Width (inch)	Load Capacity (lbs)	Overall Height (inch)	Swivel Radius (inch)	Swivel Radius w/Total Lock (inch)	Swivel Radius w/Wheel Brake (inch)
27SU40JL60	FTSU40JL60	28SU40JL60	4	2	750	5-5/8	3-3/16	4	8-1/2
27SU50JL60	FTSU50JL60	28SU50JL60	5	2	900	6-1/2	3-7/8	4	9-1/2
27SU60JL60	FTSU60JL60	28SU60JL60	6	2	1000	7-1/2	4-9/16	6	10
27SU80JL60	FTSU80JL60	28SU80JL60	8	2	1000	9-1/2	6	6	11-1/2

**TP  
WHEELS****THERMOPLASTIC RUBBER CROWN TREAD ON POLYOLEFIN CORE.**

- Non-marking thermoplastic rubber tread is permanently bonded to polyolefin core
- Shock absorbing cushioned ride offers floor protection and quiet rolling operation
- Offers good stability at low temperatures
- Resistant to cleaning chemicals, acids, alcohol, water, and is excellent for wash down applications & outdoor use, UV resistant

- Offers a smooth effortless ride, is non-marking and protects floors
- Flat tread wheels offer maximum durability at rated capacities; while round tread wheels offer an easy rolling ergonomic ride; reduced tread surface area also enables improved swiveling capabilities and turning mobility
- Color: grey or black tread
- Durometer: 75 Shore A +/-5
- Temp Range: -40°F to +180°F



Part Number Swivel Caster	Part Number Swivel with Total Lock	Part Number Rigid Caster	Wheel Diameter (inch)	Tread Width (inch)	Load Capacity (lbs)	Overall Height (inch)	Swivel Radius (inch)	Swivel Radius w/Total Lock (inch)	Swivel Radius w/Wheel Brake (inch)
27TP40JX63	FTTP40JX63	28TP40JX63	4	2	300	5-5/8	3-3/16	4	8-1/2
27TP50JX63	FTTP50JX63	28TP50JX63	5	2	350	6-1/2	3-7/8	4	9-1/2
27TP60JX63	FTTP60JX63	28TP60JX63	6	2	500	7-1/2	4-9/16	6	10
27TP80JX63	FTTP80JX63	28TP80JX63	8	2	600	9-1/2	6	6	11-1/2

**TP  
WHEELS****THERMOPLASTIC RUBBER FLAT TREAD ON POLYOLEFIN CORE.**

- Non-marking thermoplastic rubber tread is permanently bonded to polyolefin core
- Shock absorbing cushioned ride offers floor protection and quiet rolling operation
- Offers good stability at low temperatures
- Resistant to cleaning chemicals, acids, alcohol, water, and is excellent for wash down applications & outdoor use, UV resistant

- Offers a smooth effortless ride, is non-marking and protects floors
- Flat tread wheels offer maximum durability at rated capacities; while round tread wheels offer an easy rolling ergonomic ride; reduced tread surface area also enables improved swiveling capabilities and turning mobility
- Color: grey or black tread
- Durometer: 75 Shore A +/-5
- Temp Range: -40°F to +180°F



Part Number Swivel Caster	Part Number Swivel with Total Lock	Part Number Rigid Caster	Wheel Diameter (inch)	Tread Width (inch)	Load Capacity (lbs)	Overall Height (inch)	Swivel Radius (inch)	Swivel Radius w/Total Lock (inch)	Swivel Radius w/Wheel Brake (inch)
27TP40JI63	FTTP40JI63	28TP40JI63	4	2	300	5-5/8	3-3/16	4	8-1/2
27TP50JI63	FTTP50JI63	28TP50JI63	5	2	350	6-1/2	3-7/8	4	9-1/2
27TP60JI63	FTTP60JI63	28TP60JI63	6	2	500	7-1/2	4-9/16	6	10
27TP80JI63	FTTP80JI63	28TP80JI63	8	2	600	9-1/2	6	6	11-1/2

# 4 27/FT/28 SERIES KINGPIN CASTERS

## RA RUBBER MOLD ON ALUMINUM

### WHEELS

- Rubber tread vulcanized to aluminum core
- Offer shock absorbing cushioned ride, rolls over debris, offers floor protection & quiet rolling operation

- Aluminum core has a strong attractive appearance, is lightweight and is resistant to rust and corrosion
- Color: grey or black tread
- Durometer: 80 Shore A +/-5
- Temp Range: -40°F to +160°F



Part Number Swivel Caster	Part Number Swivel with Total Lock	Part Number Rigid Caster	Wheel Diameter (inch)	Tread Width (inch)	Load Capacity (lbs)	Overall Height (inch)	Swivel Radius (inch)	Swivel Radius w/Total Lock (inch)	Swivel Radius w/Wheel Brake (inch)
27RA40JB60	FT27RA40JB60	28RA40JB60	4	2	400	5-5/8	3-3/16	4	8-1/2
27RA50JB60	FT27RA50JB60	28RA50JB60	5	2	500	6-1/2	3-7/8	4	9-1/2
27RA60JB60	FT27RA60JB60	28RA60JB60	6	2	550	7-1/2	4-9/16	6	10

## NR RUBBER ON GLASS-FILLED NYLON

### WHEELS

- Soft rubber tread is molded over hard rubber core
- Shock absorbing cushioned ride and offers floor protection & quiet rolling operation
- Nylon bearing sleeve molded into wheel core, offers improved roll-ability

- Precision Ball Bearing Flanged.
- Color: black.
- Durometer: 80 Shore A +/-5
- Temp Range: -40°F to +180°F



Part Number Swivel Caster	Part Number Swivel with Total Lock	Part Number Rigid Caster	Wheel Diameter (inch)	Tread Width (inch)	Load Capacity (lbs)	Overall Height (inch)	Swivel Radius (inch)	Swivel Radius w/Total Lock (inch)	Swivel Radius w/Wheel Brake (inch)
27NR40IB60	FTNR40IB60	28NR40IB60	4	2	400	5-5/8	3-3/16	4	8-1/2
27NR50IB60	FTNR50IB60	28NR50IB60	5	2	450	6-1/2	3-7/8	4	9-1/2
27NR60IB60	FTNR60IB60	28NR60IB60	6	2	550	7-1/2	4-9/16	6	10
27NR80IB60	FTNR80IB60	28NR80IB60	8	2	600	9-1/2	6	6	11-1/2

## PU POLYURETHANE ON STEEL

### WHEELS

- Polyurethane elastomer tread chemically bonded to cast iron core
- Offers higher weight capacities while providing good floor protection and quiet rolling operation
- Sealed Precision Ball Bearing with Top Hats

- Works well in both indoor and outdoor environments; however cast iron core can rust; if this is an issue, look at using aluminum wheels.
- Durometer: 95 Shore A +/-5
- Temp Range: -40°F to +180°F

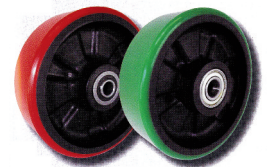

Part Number Swivel Caster	Part Number Swivel with Total Lock	Part Number Rigid Caster	Wheel Diameter (inch)	Tread Width (inch)	Load Capacity (lbs)	Overall Height (inch)	Swivel Radius (inch)	Swivel Radius w/Total Lock (inch)	Swivel Radius w/Wheel Brake (inch)
27PU40JG63	FTPU40JG63	28PU40JG63	4	2	450	5-5/8	3-3/16	4	8-1/2
27PU40JG63	FTPU40JG63	28PU40JG63	5	2	500	6-1/2	3-7/8	4	9-1/2
27PU40JG63	FTPU40JG63	28PU40JG63	6	2	600	7-1/2	4-9/16	6	10
27PU40JG63	FTPU40JG63	28PU40JG63	8	2	700	9-1/2	6	6	11-1/2

# 4 27/FT/28 SERIES KINGPIN CASTERS

## PO WHEELS

### POLYOLEFIN

- Solid injection molded polyolefin wheel construction
- High shock load, impact & abrasion resistant
- Economical & lightweight, yet offer high weight capacities
- Sealed Precision Ball Bearing Flanged

- 100% washable; impervious to water, highly resistant to organic solvents, oil, grease, most chemicals, acids & cleaning solutions
- Color: black or white tread
- Durometer: 70 Shore D +/-5
- Temp Range: -40°F to +180°F



Part Number Swivel Caster	Part Number Swivel with Total Lock	Part Number Rigid Caster	Wheel Diameter (inch)	Tread Width (inch)	Load Capacity (lbs)	Overall Height (inch)	Swivel Radius (inch)	Swivel Radius w/Total Lock (inch)	Swivel Radius w/Wheel Brake (inch)
27PO40JB60	FTPO40JB60	28PO40JB60	4	2	700	5-5/8	3-3/16	4	8-1/2
27PO50JB60	FTPO50JB60	28PO50JB60	5	2	900	6-1/2	3-7/8	4	9-1/2
27PO60JB60	FTPO60JB60	28PO60JB60	6	2	1000	7-1/2	4-9/16	6	10
27PO80JB60	FTPO80JB60	28PO80JB60	8	2	1200	9-1/2	6	6	11-1/2

## PA WHEELS

### POLYURETHANE ON ALUMINUM FLAT TREAD

- Polyurethane elastomer tread chemically bonded to a light-weight aluminum core
- Aluminum core has a strong attractive appearance, is lightweight and is resistant to rust and corrosion
- Sealed Precision Ball Bearing Flanged

- 100% washable; impervious to water, highly resistant to organic solvents, oil, grease, most chemicals, acids & cleaning solutions
- Color: red, green & blue
- Durometer: 95 Shore A +/-5
- Temp Range: -40°F to +180°F

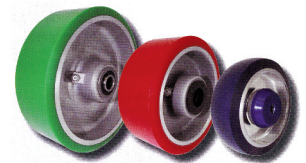

Part Number Swivel Caster	Part Number Swivel with Total Lock	Part Number Rigid Caster	Wheel Diameter (inch)	Tread Width (inch)	Load Capacity (lbs)	Overall Height (inch)	Swivel Radius (inch)	Swivel Radius w/Total Lock (inch)	Swivel Radius w/Wheel Brake (inch)
27PA40JN60	FTPA40JN60	28PA40JN60	4	2	800	5-5/8	3-3/16	4	8-1/2
27PA50JN60	FTPA50JN60	28PA50JN60	5	2	900	6-1/2	3-7/8	4	9-1/2
27PA60JN60	FTPA60JN60	28PA60JN60	6	2	1200	7-1/2	4-9/16	6	10
27PA80JN60	FTPA80JN60	28PA80JN60	8	2	1500	9-1/2	6	6	11-1/2

## MA WHEELS

### NYLON GLASS-FILLED

- Injection molded, 30% glass filled nylon wheel; has the same weight capacity of steel, yet incredibly light-weight
- 100% washable & steam cleanable, not affected by grease, oil, most chemicals & cleaning solutions, salt, brine & blood
- Sealed Precision Ball Bearing with Top Hat Bushings

- Extreme impact strength, good abrasion and compression resistance, will not flat spot.
- Offers a smooth ergonomic ride; requires less effort to start up and maintain a rolling load
- Durometer: 85 Shore D +/-5
- Temp Range: -40°F to +250°F



Part Number Swivel Caster	Part Number Swivel with Total Lock	Part Number Rigid Caster	Wheel Diameter (inch)	Tread Width (inch)	Load Capacity (lbs)	Overall Height (inch)	Swivel Radius (inch)	Swivel Radius w/Total Lock (inch)	Swivel Radius w/Wheel Brake (inch)
27MA40JB63	FTMA40JB63	28MA40JB63	4	2	800	5-5/8	3-3/16	4	8-1/2
27MA50JB63	FTMA50JB63	28MA50JB63	5	2	1000	6-1/2	3-7/8	4	9-1/2
27MA60JB63	FTMA60JB63	28MA60JB63	6	2	1200	7-1/2	4-9/16	6	10
27MA80JB63	FTMA80JB63	28MA80JB63	8	2	1250	9-1/2	6	6	11-1/2



# 4 27/FT/28 SERIES KINGPIN CASTERS

## BC WHEELS

### RUBBER ON ALUMINUM

- High modulus quality rubber tread vulcanized to aluminum core
- Rounded balloon cushion tread offers the best shock absorbing cushioned ride available, easily rolls over debris and small obstructions (electrical cords, floor joint, etc), offers maximum floor protection, high impact strength and ultra quiet rolling operation

- Sealed Precision Ball Bearing with Top Hat Bushings
- High modulus round tread minimizes surface friction and enables wheel to turn easily
- Gray or black tread colors are available; gray tread is non-marking
- Durometer: 60 Shore A +/-5
- Temp Range: -40°F to +180°F

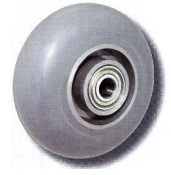

Part Number Swivel Caster	Part Number Swivel with Total Lock	Part Number Rigid Caster	Wheel Diameter (inch)	Tread Width (inch)	Load Capacity (lbs)	Overall Height (inch)	Swivel Radius (inch)	Swivel Radius w/Total Lock (inch)	Swivel Radius w/Wheel Brake (inch)
27BC60J63	FTBC60J63	28BC60J63	6	2	350	7-1/2	4-9/16	6	10
27BC80J63	FTBC80J63	28BC80J63	8	2	450	9-1/2	6	6	11-1/2

## UA WHEELS

### RUBBER ON ALUMINUM

- Uniquely formulated "Flex Compound" polyurethane elastomer is chemically and mechanically bonded to a precision aluminum core; double bonding helps prevent tread separation and assures reliable mobility
- Combination of the round tread and sealed precision ball bearings minimizes surface friction, enables wheel to turn easily and requires less effort to startup and maintain a rolling load

- Sealed Precision Ball Bearing with Top Hat Bushings
- Offers a semi-cushioned ride, is non-marking and is capable of rolling over debris (metal shavings, door & floor joints, etc.)
- Great for manual or power assisted (towline) applications
- Durometer: 85 Shore A +/-5
- Temp Range: -40°F to +180°F



Part Number Swivel Caster	Part Number Swivel with Total Lock	Part Number Rigid Caster	Wheel Diameter (inch)	Tread Width (inch)	Load Capacity (lbs)	Overall Height (inch)	Swivel Radius (inch)	Swivel Radius w/Total Lock (inch)	Swivel Radius w/Wheel Brake (inch)
27UA60JN63	FTUA60JN63	28UA60JN63	6	2	900	7-1/2	4-9/16	6	10
27UA80JN63	FTUA80JN63	28UA80JN63	8	2	1000	9-1/2	6	6	11-1/2

## CP WHEELS

### POLYURETHANE ON ELASTOMER TREAD

- 1-3/16" thick ultra-flex compound polyurethane elastomer tread chemically bonded to a mag style aluminum core, sets a new standard in high quality wheels; maximizing load capacity, shock load, and vibration stabilization
- Combination of the thick ultra-flex tread and oversized sealed precision ball bearings minimizes rolling resistance

- Sealed Precision Ball Bearing with Top Hat Bushings
- Elastic properties of ultra-flex tread provide excellent abrasion resistance and a cushioned ride that easily rolls over debris and small obstructions. Offers maximum floor protection, high impact strength and ultra quiet rolling operation
- Great for manual or power assisted applications
- Color: green
- Durometer: 70 Shore A +/-5
- Temp Range: -40°F to +180°F



Part Number Swivel Caster	Part Number Swivel with Total Lock	Part Number Rigid Caster	Wheel Diameter (inch)	Tread Width (inch)	Load Capacity (lbs)	Overall Height (inch)	Swivel Radius (inch)	Swivel Radius w/Total Lock (inch)	Swivel Radius w/Wheel Brake (inch)
27CP60JN64	FTCP60JN64	28CP60JN64	6	2	1200	7-1/2	4-9/16	6	10
27CP80JN64	FTCP80JN64	28CP80JN64	8	2	1500	9-1/2	6	6	11-1/2

**PH  
WHEELS****PHENOLIC**

- Phenolic resin mixed with macerated canvas; creates a high capacity, high impact resistant wheel that has many years of proven reliability in the industry
- Hard tread rolls easily, provides good concrete floor protection and is quieter than steel wheels
- Sealed Precision Ball Bearing Flanged

- Resistant to oil, grease & solvents, non-metallic and non-sparking
- Economically priced wheel
- Zerk fitting are not standard, but available upon request
- Durometer: 90 Shore D +/-5
- Temp Range: -50°F to +250°F



Part Number Swivel Caster	Part Number Swivel with Total Lock	Part Number Rigid Caster	Wheel Diameter (inch)	Tread Width (inch)	Load Capacity (lbs)	Overall Height (inch)	Swivel Radius (inch)	Swivel Radius w/Total Lock (inch)	Swivel Radius w/Wheel Brake (inch)
27PH34JB60	FTPH34JB60	28PH34JB60	3-1/4	2	700	4-1/4	1-3/4	4	8-1/2
27PH40JB60	FTPH40JB60	28PH40JB60	4	2	800	5-5/8	3-3/16	4	8-1/2
27PH50JB60	FTPH50JB60	28PH50JB60	5	2	1000	6-1/2	3-7/8	4	9-1/2
27PH60JB60	FTPH60JB60	28PH60JB60	6	2	1200	7-1/2	4-9/16	6	10
27PH80JB60	FTPH80JB60	28PH80JB60	8	2	1250	9-1/2	6	6	11-1/2

**HI-TEMP PHENOLIC** +550°F intermittent (part# TPH)

- Stainless Steel Roller Bearing.

Part Number Swivel Caster	Part Number Swivel with Total Lock	Part Number Rigid Caster	Wheel Diameter (inch)	Tread Width (inch)	Load Capacity (lbs)	Overall Height (inch)	Swivel Radius (inch)	Swivel Radius w/Total Lock (inch)	Swivel Radius w/Wheel Brake (inch)
27HT40JB05	FTHT40JB05	28HT40JB05	4	2	800	5-5/8	3-3/16	4	8-1/2
27HT50JB05	FTHT50JB05	28HT50JB05	5	2	1000	6-1/2	3-7/8	4	9-1/2
27HT60JB05	FTHT60JB05	28HT60JB05	6	2	1200	7-1/2	4-9/16	6	10
27HT80JB05	FTHT80JB05	28HT80JB05	8	2	1250	9-1/2	6	6	11-1/2

**SW  
WHEELS****POLYURETHANE ON ELASTOMER TREAD**

- Crowned polyurethane elastomer tread chemically bonded to a solid heavy-duty cast iron core
- Combination of crowned tread and heavy core, offers higher weight capacities, durability and greater mobility
- Sealed Precision Ball Bearings

- Provides good floor protection and quiet rolling operation
- Color: dark blue on black
- Durometer: 95 Shore D +/-5
- Temp Range: -40°F to +180°F



Part Number Swivel Caster	Part Number Swivel with Total Lock	Part Number Rigid Caster	Wheel Diameter (inch)	Tread Width (inch)	Load Capacity (lbs)	Overall Height (inch)	Swivel Radius (inch)	Swivel Radius w/Total Lock (inch)	Swivel Radius w/Wheel Brake (inch)
27SW60JU63	FTSW60JU63	28SW60JU63	6	2	1400	7-1/2	4-9/16	6	10
27SW80JU63	FTSW80JU63	28SW80JU63	8	2	1500	9-1/2	6	6	11-1/2

# 4 27/FT/28 SERIES KINGPIN CASTERS

## RP WHEELS

### ROUND TREAD POLYURETHANE ON CAST IRON CORE

- Uniquely formulated “Flex Compound” polyurethane elastomer is chemically bonded to heavy cast iron core
- Combination of the round tread and sealed precision ball bearings minimizes surface friction, enables wheel to turn easily and requires less effort to startup and maintain a rolling load
- Sealed Precision Ball Bearing with Top Hat Bushings
- Offers a semi-cushioned ride, is non-marking and is capable of rolling over debris (metal shavings, door & floor joints, etc.)
- Color: gray & black.
- Durometer: 80 Shore A +/-5
- Temp Range: -40°F to +180°F



Part Number Swivel Caster	Part Number Swivel with Total Lock	Part Number Rigid Caster	Wheel Diameter (inch)	Tread Width (inch)	Load Capacity (lbs)	Overall Height (inch)	Swivel Radius (inch)	Swivel Radius w/Total Lock (inch)	Swivel Radius w/Wheel Brake (inch)
27RP40JK63	FTRP40JK63	28RP40JK63	4	2	700	5-5/8	3-3/16	4	8-1/2
27RP50JK63	FTRP50JK63	28RP50JK63	5	2	800	6-1/2	3-7/8	4	9-1/2
27RP60JK63	FTRP60JK63	28RP60JK63	6	2	900	7-1/2	4-9/16	6	10
27RP80JK63	FTRP80JK63	28RP80JK63	8	2	1000	9-1/2	6	6	11-1/2

## RH WHEELS

### SUPREME RUBBER ON CAST IRON CORE

- High quality supreme rubber tread with a tensile strength of 1200 to 1400 PSI, vulcanized to a solid heavy duty cast iron core
- Upgraded tread material, core design and bearings; provide the perfect combination needed for use on tow lines and other demanding applications that normal mold-on rubber wheels may not be able to withstand
- Sealed Precision Ball Bearing with Top Hat Bushings
- Offers a shock absorbing semi-cushioned ride, rolls over small debris, uneven surfaces, cracks floor joints, etc
- Provides good floor protection and quiet rolling operation
- Durometer: 75 Shore A +/-5
- Temp Range: -40°F to +180°F



Part Number Swivel Caster	Part Number Swivel with Total Lock	Part Number Rigid Caster	Wheel Diameter (inch)	Tread Width (inch)	Load Capacity (lbs)	Overall Height (inch)	Swivel Radius (inch)	Swivel Radius w/Total Lock (inch)	Swivel Radius w/Wheel Brake (inch)
27RH60JS63	FTRH60JS63	28RH60JS63	6	2	700	7-1/2	4-9/16	6	10
27RH80JS63	FTRH80JS63	28RH80JS63	8	2	800	9-1/2	6	6	11-1/2

# 31 SERIES KINGPIN STAINLESS STEEL CASTERS



**SWIVEL CASTER AND TOTAL LOCK STAINLESS STEEL CASTER WITH KR WHEEL**  
Add TL to swivel caster number



**STAINLESS STEEL FOOT ACTIVATED SWIVEL LOCK**



**TECH-LOCK PEDAL BRAKE**  
H

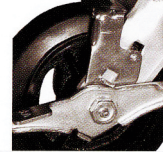

**TOP-LOCK BRAKE**  
T

**OPTION RACEWAY SEALS**

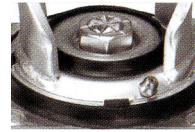

**L**  
Thermo - plastic  
up to 140° F



**H**  
H.T. Neoprene  
up to 380° F

## 1,250 LBS. LOAD CAPACITY STAINLESS STEEL TYPE CASTERS

- All metal parts made from 304 Stainless Steel 100% washable
- Double Ball Raceway offers smooth swiveling action, strength and long service life.
- Wash down, high temperature autoclavable wheels
- 1/4" Thick Fork Legs Robotically welded 2 1/2" spacing
- Kingpin 5/8" nut & bolt
- 1/2" Wheel axle
- Stainless Steel Precision Ball Bearings
- Polished Stainless Steel Rig available add "P"

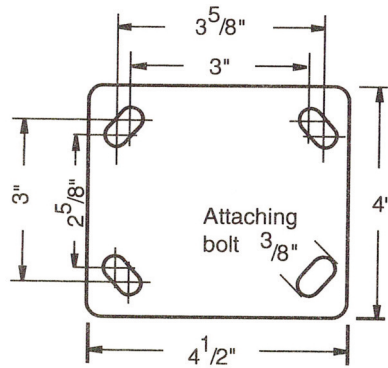

**TOP PLATE**  
4 X 4-1/2

**BOLT HOLE CENTER**  
2-5/8 X 3-5/8  
**SLOTTED TO**  
3 X 3

**ATTACHING BOLT SIZE**  
3/8

**ALL WHEELS AVAILABLE WITH STAINLESS STEEL ROLLER BEARINGS OR DELRIN BUSHING**

NY/MD  
WHEELS

## NYLACRON™ WHEELS

- Precision Machined from Cast Polyamide. Hardness 112-120 Rockwell R
- Ultimate choice for Extremely High Load applications to replace metallic wheels
- Offer very high abrasion resistance and very low rolling resistance under extreme loads

- Resistant to salt, grease, alcohol and mild acids - can be used in corrosive applications with appropriate bearings
- Stainless Steel Precision Ball Bearings
- Temperature Range: -40°F to +270°F

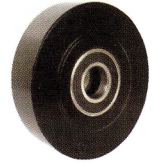

Part Number Swivel Caster	Part Number Swivel with Total Lock	Part Number Rigid Caster	Wheel Diameter (inch)	Tread Width (inch)	Load Capacity (lbs)	Overall Height (inch)	Swivel Radius (inch)	Swivel Radius w/Total Lock (inch)	Swivel Radius w/Wheel Brake (inch)
31SS42NYMD	32SS42NYMDTL	TSSS42NYMD	4	2	1250	5-5/8	3-3/16	4	8-1/2
31SS52NYMD	32SS52NYMDTL	TSSS52NYMD	5	2	1250	6-1/2	3-7/8	4	9-1/2
31SS62NYMD	32SS62NYMDTL	TSSS62NYMD	6	2	1250	7-1/2	4-9/16	6	10
31SS82NYMD	32SS82NYMDTL	TSSS82NYMD	8	2	1250	9-1/2	6	6	11-1/2

NY/MC  
WHEELS

## NYLACRON™ WHEELS WHITE

- Precision Machined from Cast Polyamide. Hardness 112-120 Rockwell R
- Ultimate choice for Extremely High Load applications to replace metallic wheels
- Offer very high abrasion resistance and very low rolling resistance under extreme loads

- Resistant to salt, grease, alcohol and mild acids - can be used in corrosive applications with appropriate bearings
- Stainless Steel Precision Ball Bearings
- Temperature Range: -40°F to +270°F



Part Number Swivel Caster	Part Number Swivel with Total Lock	Part Number Rigid Caster	Wheel Diameter (inch)	Tread Width (inch)	Load Capacity (lbs)	Overall Height (inch)	Swivel Radius (inch)	Swivel Radius w/Total Lock (inch)	Swivel Radius w/Wheel Brake (inch)
31SS42NYMC	32SS42NYMCTL	TSSS42NYMC	4	2	1250	5-5/8	3-3/16	4	8-1/2
31SS52NYMC	32SS52NYMCTL	TSSS52NYMC	5	2	1250	6-1/2	3-7/8	4	9-1/2
31SS62NYMC	32SS62NYMCTL	TSSS62NYMC	6	2	1250	7-1/2	4-9/16	6	10
31SS82NYMC	32SS82NYMCTL	TSSS82NYMC	8	2	1250	9-1/2	6	6	11-1/2

NN  
WHEELS

## NYLON WHEELS

- Injection molded from Nylon 6
- 100% washable & steam cleanable; impervious to water, highly resistant to organic solvents, most chemicals & cleaning solutions; ideal for use in food processing and packaging plants
- Offer high impact strength and exception abrasion resistance

- Hard tread has slight crown and rolls very easily
- Non-marking
- Durometer: 75 Shore D (+/-5)
- Stainless Steel Precision Ball Bearings
- Temperature Range: -40°F to +180°F
- Available in Anti-Static add "AS"



Part Number Swivel Caster	Part Number Swivel with Total Lock	Part Number Rigid Caster	Wheel Diameter (inch)	Tread Width (inch)	Load Capacity (lbs)	Overall Height (inch)	Swivel Radius (inch)	Swivel Radius w/Total Lock (inch)	Swivel Radius w/Wheel Brake (inch)
31SS42NN	32SS42NNTL	TSSS42NN	4	2	1250	5-5/8	3-3/16	4	8-1/2
31SS52NN	32SS52NNTL	TSSS52NN	5	2	1250	6-1/2	3-7/8	4	9-1/2
31SS62NN	32SS62NNTL	TSSS62NN	6	2	1250	7-1/2	4-9/16	6	10
31SS82NN	32SS82NNTL	TSSS82NN	8	2	1250	9-1/2	6	6	11-1/2

SS  
WHEELS

## STAINLESS STEEL WHEELS

- Type 304 Stainless Steel
- Non-magnetic & Non-sparking
- Excellent corrosion resistance
- Slightly crowned tread face with rounded corners

- Stainless Steel Precision Ball Bearings
- Temperature Range: 800°F

**Custom Stainless Steel Wheels  
made to your specifications**

**V-Groove - VG  
Flanged - FL**



Part Number Swivel Caster	Part Number Swivel with Total Lock	Part Number Rigid Caster	Wheel Diameter (inch)	Tread Width (inch)	Load Capacity (lbs)	Overall Height (inch)	Swivel Radius (inch)	Swivel Radius w/Total Lock (inch)	Swivel Radius w/Wheel Brake (inch)
31SS42SS	32SS42SS	TSSS42SS	4	2	1250	5-5/8	3-3/16	4	8-1/2
31SS52SS	32SS52SS	TSSS52SS	5	2	1250	6-1/2	3-7/8	4	9-1/2
31SS62SS	32SS62SS	TSSS62SS	6	2	1250	7-1/2	4-9/16	6	10
31SS82SS	32SS82SS	TSSS82SS	8	2	1250	9-1/2	6	6	11-1/2

SEN  
WHEELS

## SOLID ELASTOMER WHEEL NYLON CORE

- 70 Shore (D) durometer
- FDA standards for use in food processing environments
- 100% Washable

- Glass-filled nylon core insert endures heat
- High impact and abrasion resistant
- Resists oil, grease, water, and most solvents
- Stainless Steel Precision Ball Bearings
- Temp Range: -50°F to +180°F



Part Number Swivel Caster	Part Number Swivel with Total Lock	Part Number Rigid Caster	Wheel Diameter (inch)	Tread Width (inch)	Load Capacity (lbs)	Overall Height (inch)	Swivel Radius (inch)	Swivel Radius w/Total Lock (inch)	Swivel Radius w/Wheel Brake (inch)
31SS42SEN	32SS42SEN	TSSS42SEN	4	2	900	5-5/8	3-3/16	4	8-1/2
31SS52SEN	32SS52SEN	TSSS52SEN	5	2	900	6-1/2	3-7/8	4	9-1/2
31SS62SEN	32SS62SEN	TSSS62SEN	6	2	900	7-1/2	4-9/16	6	10
31SS82SEN	32SS82SEN	TSSS82SEN	8	2	900	9-1/2	6	6	11-1/2

KR  
WHEELS

## SOLID POLYURETHANE KRYTONIC™ WHEELS

- Polyether Polyurethane has excellent carrying capacity.
- Crown shape affords an easy-rolling quiet operation
- Greater service life and resistance to chunking, cutting and abrasive wear

- 100% washable, steam cleanable, and resistant to most chemicals
- Non-marking tread
- Durometer: 58 Shore D (+/-5)
- Stainless Steel Precision Ball Bearings
- Temperature Range: + 250°F for up to a 1/2 hour.



Part Number Swivel Caster	Part Number Swivel with Total Lock	Part Number Rigid Caster	Wheel Diameter (inch)	Tread Width (inch)	Load Capacity (lbs)	Overall Height (inch)	Swivel Radius (inch)	Swivel Radius w/Total Lock (inch)	Swivel Radius w/Wheel Brake (inch)
31SS42KR	32SS42KR	TSSS42KR	4	2	800	5-5/8	3-3/16	4	8-1/2
31SS52KR	32SS52KR	TSSS52KR	5	2	900	6-1/2	3-7/8	4	9-1/2
31SS62KR	32SS62KR	TSSS62KR	6	2	900	7-1/2	4-9/16	6	10
31SS82KR	32SS82KR	TSSS82KR	8	2	900	9-1/2	6	6	11-1/2

## OTHER TYPE WHEELS AVAILABLE FOR THIS SERIES:

NYLON FIBERGLASS (NG), NYLACRON™ MD (NY/MD), NYLACRON™ MONOCAST (NY/MC), HIGH TEMP PHENOLIC (TR) AND HEATEATER (HE)  
SEE WHEEL SECTION FOR COMPLETE SPECIFICATIONS.

HE  
WHEELS

## HI-TEMP NYLON WHEELS

- Ideal for speciality applications
- Won't chip, absorbs water or breakdown in caustic environments

- Moderate crown, black finish
- Durometer: 85 Shore D +5
- Stainless Steel Rolling Bearings
- Temperature Range: up to +475°F



Part Number Swivel Caster	Part Number Swivel with Total Lock	Part Number Rigid Caster	Wheel Diameter (inch)	Tread Width (inch)	Load Capacity (lbs)	Overall Height (inch)	Swivel Radius (inch)	Swivel Radius w/Total Lock (inch)	Swivel Radius w/Wheel Brake (inch)
31SS42HEZB03	32SS42HEZB03	TSSS42HEZB03	4	2	800	5-5/8	3-3/16	4	8-1/2
31SS52HEZB03	32SS52HEZB03	TSSS52HEZB03	5	2	1000	6-1/2	3-7/8	4	9-1/2
31SS62HEZB03	32SS62HEZB03	TSSS62HEZB03	6	2	1200	7-1/2	4-9/16	6	10
31SS82HEZB03	32SS82HEZB03	TSSS82HEZB03	8	2	1400	9-1/2	6	6	11-1/2

RW  
WHEELS

## RETORT POLYPROPYLENE WHEELS

- Designed to withstand the rigors of high temperature
- Oversized bore ID ensures smooth movement even if wheels experience heat expansion

- Moderate crown, white finish
- Durometer: 75 Shore D
- Stainless Steel Rolling Bearings
- Temperature Range: -20°F to +290°F



Part Number Swivel Caster	Part Number Swivel with Total Lock	Part Number Rigid Caster	Wheel Diameter (inch)	Tread Width (inch)	Load Capacity (lbs)	Overall Height (inch)	Swivel Radius (inch)	Swivel Radius w/Total Lock (inch)	Swivel Radius w/Wheel Brake (inch)
31SS42RWZB03	32SS42RWZB03	TSSS42RWZB03	4	2	500	5-5/8	3-3/16	4	8-1/2
31SS52RWZB03	32SS52RWZB03	TSSS52RWZB03	5	2	1250	6-1/2	3-7/8	4	9-1/2
31SS62RWZB03	32SS62RWZB03	TSSS62RWZB03	6	2	1250	7-1/2	4-9/16	6	10
31SS82RWZB03	32SS82RWZB03	TSSS82RWZB03	8	2	1250	9-1/2	6	6	11-1/2

NG  
WHEELS

## GLASS FILLED NYLON WHEELS

- Injection molded, 30% glass filled nylon wheel
- 100% washable & steam cleanable, not affected by grease, oils, most chemicals & cleaning solutions, salt, brine & blood
- Extreme impact strength, good abrasion and compression resistance

- Offers a smooth ergonomic ride; requires less effort to start up and maintain a rolling load
- Durometer: 85 Shore D (+/-5)
- Stainless Steel Pedestal Precision Ball Bearings
- Temperature Range: -45°F to +250°F up to 3500 F, when used with all metallic bearings and high-temp grease



Part Number Swivel Caster	Part Number Swivel with Total Lock	Part Number Rigid Caster	Wheel Diameter (inch)	Tread Width (inch)	Load Capacity (lbs)	Overall Height (inch)	Swivel Radius (inch)	Swivel Radius w/Total Lock (inch)	Swivel Radius w/Wheel Brake (inch)
31SS42NG	32SS42NG	TSSS42NG	4	2-3/16	800	5-5/8	3-3/16	4	8-1/2
31SS52NG	32SS52NG	TSSS52NG	5	2-3/16	1000	6-1/2	3-7/8	4	9-1/2
31SS62NG	32SS62NG	TSSS62NG	6	2-3/16	1200	7-1/2	4-9/16	6	10
31SS82NG	32SS82NG	TSSS82NG	8	2-3/16	1400	9-1/2	6	6	11-1/2



HYDRAULIC RIVET SWIVEL

STAINLESS STEEL  
FOOT ACTIVATED SWIVEL LOCK

ALL WHEELS  
AVAILABLE WITH  
STAINLESS STEEL  
ROLLER BEARINGS  
OR  
DELTRIN BUSHING

## 1,250 LBS. LOAD CAPACITY STAINLESS STEEL KINGPINLESS TYPE CASTERS

- **Top Plate & Yoke Base:** Formed from superior 1/4" Type 304 stainless steel
- **Finish:** Highly polished stainless steel
- **Swivel Section:** Double stainless steel ball bearing raceways formed smooth for ease of swiveling
- **King Pin:** Stainless steel rivet
- **Axle:** 1/2" diameter, stainless steel hollow with roller bearings. Stainless steel axle with precision ball bearings
- **Fork Legs:** 1/4" stainless steel formed for added strength welded to yoke base
- **Spanner Bushing:** Type 304 Stainless Steel
- **Zerk Fitting:** Type 304 Stainless Steel
- **NSF:** Consult factory
- Alternate or custom caster configurations available

*This caster is the ideal solution for applications where frequent washdowns are necessary. The stainless steel caster is also well suited for applications exposed to cleaning agents, steam, caustic solutions, or other corrosive agents which could cause rust.*

### MOUNTING PLATE OPTIONS

#### TOP PLATE: 05 (STANDARD)

- **Plate Size:** 4 x 4-1/2
- **Bolt Holes:** 2-5/8 x 3-5/8  
slotted to 3 x 3
- **Bolt Size:** 3/8

### BEARING OPTIONS

- Stainless Steel Roller (01)
- Stainless Steel Precision Ball (28)
- Stainless Steel Pedestal Ball (29)

### RIG OPTIONS

- Neoprene sealed swivel section. Specify **NS05**
- NSF Listed for food service industry. Specify **NSF**
- Notched seal kit. Specify **SD016001**
- Unnotched seal kit. Specify **SD016002**

### BRAKES OPTIONS

Stainless Steel  
Cam  
specify **CB1**



Stainless Steel  
Face Brake  
specify **FBD**

Foot Activated  
Swivel Lock  
specify **SL 160002**



### TYPICAL APPLICATIONS

- Institutional
- Hospitality
- Food Service
- Pharmaceuticals
- Hotel Luggage Carts
- Hospital Beds
- Stock Carts
- Laundry Trucks
- Dollies

## IMPROVE ROLLABILITY WITH THE ERGONOMIC ADVANTAGE

**PRECISION BALL BEARINGS** - Completely sealed, these precision ground ball bearings are constructed using hardened raceways to give you the ultimate in rolling ease. In fact, this bearing offers the lowest rolling resistance of all of our bearings. Bearings never need to be lubricated to cut maintenance time and cost.

ALL BALL AND PRECISION BEARING WHEELS WITH 2-1/2" HUB LENGTH WILL FIT IN ALL 4 CATEGORY SERIES CASTERS  
See Wheel Section for complete selection.



## 4

## 05 SERIES KINGPIN STAINLESS STEEL CASTERS

**X-TRA SOFT  
FLAT TREAD  
01 ROLLER BEARING  
XS**

- Prevenz™ antimicrobial models available
- Add PREV to end of caster number
- Stainless Steel Roller 01 ZB03 and Delrin 51 Bearings available
- Change “01” to other breaking code
- Stainless Steel Roller Example: 05XS0420**1 ZB03**

Part Number Swivel Caster	Part Number Rigid Caster	Wheel Diameter (inch)	Tread Width (inch)	Load Capacity (lbs)	Overall Height (inch)	Swivel Lead (inch)	Approx. Weight (lbs)
05XS0420 <b>1S</b>	05XS0420 <b>1R</b>	4	2	350	5-5/8	1-7/16	5-1/4
05XS0520 <b>1S</b>	05XS0520 <b>1R</b>	5	2	375	6-1/2	1-5/8	5-1/4
05XS0620 <b>1S</b>	05XS0620 <b>1R</b>	6	2	600	7-1/2	1-7/8	5-3/4
05XS0820 <b>1S</b>	05XS0820 <b>1R</b>	8	2	675	9-1/2	2-3/8	6

**X-TRA SOFT  
ROUND TREAD  
01 ROLLER BEARING  
XR**

- Prevenz™ antimicrobial models available
- Add PREV to end of caster number
- Stainless Steel Roller 01 ZB03 and Delrin 51 Bearings available
- Change “01” to other breaking code
- Stainless Steel Roller Example: 05XS0620**1 ZB03**

Part Number Swivel Caster	Part Number Rigid Caster	Wheel Diameter (inch)	Tread Width (inch)	Load Capacity (lbs)	Overall Height (inch)	Swivel Lead (inch)	Approx. Weight (lbs)
05XR0620 <b>1S</b>	05XR0620 <b>1R</b>	6	2	600	7-1/2	1-7/8	5-3/4
05XR0820 <b>1S</b>	05XR0820 <b>1R</b>	8	2	675	9-1/2	2-3/8	6

**HIGH MODULUS RUBBER ON  
ALUMINUM  
28 PRECISION BALL BEARING  
RM**

- For black tread specify “RL” wheel code  
Example: 5**RL**05228

Part Number Swivel Caster	Part Number Rigid Caster	Wheel Diameter (inch)	Tread Width (inch)	Load Capacity (lbs)	Overall Height (inch)	Swivel Lead (inch)	Approx. Weight (lbs)
05RM0522 <b>8S</b>	05RM0522 <b>8R</b>	5	2	300	6-1/2	1-5/8	5-1/2
05RM0622 <b>8S</b>	05RM0622 <b>8R</b>	6	2	350	7-1/2	1-7/8	6-1/2
05RM0822 <b>8S</b>	05RM0822 <b>8R</b>	8	2	450	9-1/2	2-3/8	8-1/2

**MOLDON ON RUBBER  
ON ALUMINUM  
01 ROLLER BEARING  
MD**

Part Number Swivel Caster	Part Number Rigid Caster	Wheel Diameter (inch)	Tread Width (inch)	Load Capacity (lbs)	Overall Height (inch)	Swivel Lead (inch)	Approx. Weight (lbs)
05MD0410 <b>1S</b>	05MD0410 <b>1R</b>	4	2	250	5-5/8	1-7/16	4-3/4
05MD0510 <b>1S</b>	05MD0510 <b>1R</b>	5	2	300	6-1/2	1-5/8	5
05MD0610 <b>1S</b>	05MD0610 <b>1R</b>	6	2	550	7-1/2	1-7/8	6
05MD0810 <b>1S</b>	05MD0810 <b>1R</b>	8	2	600	9-1/2	2-3/8	6-1/2

**POLYPROPYLENE  
01 ROLLER BEARING****PB**

- Stainless Steel Roller 01 ZB03 and Delrin 51 Bearings available
- Change "01" to other breaking code

- Stainless Steel Roller Example: 05XS04201 ZB03

Part Number Swivel Caster	Part Number Rigid Caster	Wheel Diameter (inch)	Tread Width (inch)	Load Capacity (lbs)	Overall Height (inch)	Swivel Lead (inch)	Approx. Weight (lbs)
05PB04201S	05PB04201R	4	2	450	5-5/8	1-7/16	3-3/4
05PB05201S	05PB05201R	5	2	550	6-1/2	1-5/8	4-1/2
05PB06201S	05PB06201R	6	2	650	7-1/2	1-7/8	4-3/4
05PB08201S	05PB08201R	8	2	850	9-1/2	2-3/8	6-1/4

**FIBERGLASS FILLED  
POLYPROPYLENE  
01 ROLLER BEARING****GP**

- Stainless Steel Roller 01 ZB03 and Delrin 51 Bearings available
- Change "01" to other breaking code

- Stainless Steel Roller Example: 05XS06201 ZB03

Part Number Swivel Caster	Part Number Rigid Caster	Wheel Diameter (inch)	Tread Width (inch)	Load Capacity (lbs)	Overall Height (inch)	Swivel Lead (inch)	Approx. Weight (lbs)
05GP04201S	05GP04201R	4	2	800	5-5/8	1-7/16	5
05GP05201S	05GP05201R	5	2	1000	6-1/2	1-5/8	5-1/4
05GP06201S	05GP06201R	6	2	1200	7-1/2	1-7/8	5-3/4
05GP08201S	05GP08201R	8	2	1200	9-1/2	2-3/8	7

**RETORT HIGH TEMP  
POLYPROPYLENE  
41 PLAIN BORE****RW**

Part Number Swivel Caster	Part Number Rigid Caster	Wheel Diameter (inch)	Tread Width (inch)	Load Capacity (lbs)	Overall Height (inch)	Swivel Lead (inch)	Approx. Weight (lbs)
05RW04201S	05RW04201R	4	2	500	5-5/8	1-7/16	3-3/4
05RW05201S	05RW05201R	5	2	650	6-1/2	1-5/8	5-1/4
05RW06201S	05RW06201R	6	2	700	7-1/2	1-7/8	5-1/2
05RW08201S	05RW08201R	8	2	900	9-1/2	2-3/8	6-1/4

**POLYURETHANE ON  
ALUMINUM ROUND TREAD  
28 PRECISION BALL BEARING****PM**

Part Number Swivel Caster	Part Number Rigid Caster	Wheel Diameter (inch)	Tread Width (inch)	Load Capacity (lbs)	Overall Height (inch)	Swivel Lead (inch)	Approx. Weight (lbs)
05PM05101S	05PM05101R	5	2	1000	6-1/2	1-5/8	6
05PM06101S	05PM06101R	6	2	1200	7-1/2	1-7/8	7
05PM08101S	05PM08101R	8	2	1200	9-1/2	2-3/8	9

## 4

## 05 SERIES KINGPIN STAINLESS STEEL CASTERS

**POLYURETHANE ON  
POLYPROPYLENE  
01 ROLLER BEARING  
XA**

- Prevenz™ antimicrobial models available
- Add PREV to end of caster number
- Stainless Steel Roller 01 ZB03 and Delrin 51 Bearings available
- Change "01" to other breaking code
- Stainless Steel Roller Example: 05XS04201 **ZB03**

Part Number Swivel Caster	Part Number Rigid Caster	Wheel Diameter (inch)	Tread Width (inch)	Load Capacity (lbs)	Overall Height (inch)	Swivel Lead (inch)	Approx. Weight (lbs)
05XA04201S	05XA04201R	4	2	600	5-5/8	1-7/16	5
05XA05201S	05XA05201R	5	2	750	6-1/2	1-5/8	5-1/4
05XA06201S	05XA06201R	6	2	900	7-1/2	1-7/8	5-3/4
05XA08201S	05XA08201R	8	2	1000	9-1/2	2-3/8	7

**X-TREME™  
PLUS SOLID  
POLYURETHANE  
01 ROLLER BEARING  
XI**

- Prevenz™ antimicrobial models available
- Add PREV to end of caster number
- Stainless Steel Roller 01 ZB03, Bronze 22, Pedestal Precision 29, Annular Ball 31 and Delrin 51 Bearings available
- Change "01" to other breaking code
- Stainless Steel Roller Example: 05XI04229

Part Number Swivel Caster	Part Number Rigid Caster	Wheel Diameter (inch)	Tread Width (inch)	Load Capacity (lbs)	Overall Height (inch)	Swivel Lead (inch)	Approx. Weight (lbs)
05XI04201S	05XI04201R	4	2	1000	5-5/8	1-7/16	4-1/4
05XI05201S	05XI05201R	5	2	1000	6-1/2	1-5/8	5
05XI06201S	05XI06201R	6	2	1000	7-1/2	1-7/8	5-1/2
05XI08201S	05XI08201R	8	2	1000	9-1/2	2-3/8	6-1/2

**PHENOLIC  
01 ROLLER BEARING  
TM**

- Stainless Steel Roller 01 ZB03 and Delrin 51 Bearings available
- Change "01" to other breaking code
- Stainless Steel Roller Example: 05XS04201 **ZB03**

Part Number Swivel Caster	Part Number Rigid Caster	Wheel Diameter (inch)	Tread Width (inch)	Load Capacity (lbs)	Overall Height (inch)	Swivel Lead (inch)	Approx. Weight (lbs)
05TM04201S	05TM04201R	4	2	800	5-5/8	1-7/16	5
05TM05201S	05TM05201R	5	2	1000	6-1/2	1-5/8	5-1/4
05TM06201S	05TM06201R	6	2	1200	7-1/2	1-7/8	6-1/4
05TM08201S	05TM08201R	8	2	1200	9-1/2	2-3/8	8

**MAXIM®**  
**01 ROLLER BEARING**  
**NG**

- Prevenz™ antimicrobial models available
- Add PREV to end of caster number
- Stainless Steel Roller 01 ZB03, Bronze 22, Pedestal Precision 29, Annular Ball 31 and Delrin 51 Bearings available
- Change “01” to other breaking code
- Stainless Steel Roller Example: 05XI042**29**
- Add **NR** for Noise Reduction

Part Number Swivel Caster	Part Number Rigid Caster	Wheel Diameter (inch)	Tread Width (inch)	Load Capacity (lbs)	Overall Height (inch)	Swivel Lead (inch)	Approx. Weight (lbs)
05NG04201S	05NG04201R	4	2	800	5-5/8	1-7/16	5
05NG05201S	05NG05201R	5	2	1000	6-1/2	1-5/8	5-1/4
05NG06201S	05NG06201R	6	2	1200	7-1/2	1-7/8	5-3/4
05NG08201S	05NG08201R	8	2	1200	9-1/2	2-3/8	7

**HI-TEMP NYLON**  
**01 ROLLER BEARING**  
**HE**

- Stainless Steel Roller 01 ZB03 and Delrin 51 Bearings available
- Change “01” to other breaking code
- Stainless Steel Roller Example: 05XS04201 **ZB03**

Part Number Swivel Caster	Part Number Rigid Caster	Wheel Diameter (inch)	Tread Width (inch)	Load Capacity (lbs)	Overall Height (inch)	Swivel Lead (inch)	Approx. Weight (lbs)
05HE04201S	05HE04201R	4	2	800	5-5/8	1-7/16	3-3/4
05HE05201S	05HE05201R	5	2	1000	6-1/2	1-5/8	5-1/4
05HE06201S	05HE06201R	6	2	1200	7-1/2	1-7/8	5-3/4
05HE08201S	05HE08201R	8	2	1200	9-1/2	2-3/8	6-1/2

**DROP FORGED STEEL**  
**01 ROLLER BEARING**  
**FS**

- Stainless Steel Roller 01 ZB03 and Delrin 51 Bearings available
- Change “01” to other breaking code
- Stainless Steel Roller Example: 05XS04201 **ZB03**
- Stainless steel drop forged wheels available

Part Number Swivel Caster	Part Number Rigid Caster	Wheel Diameter (inch)	Tread Width (inch)	Load Capacity (lbs)	Overall Height (inch)	Swivel Lead (inch)	Approx. Weight (lbs)
05FS04201S	05FS04201R	4	2	800	5-5/8	1-7/16	7
05FS05201S	05FS05201R	5	2	1000	6-1/2	1-5/8	8-3/4
05FS06201S	05FS08201R	6	2	1200	7-1/2	1-7/8	9-3/4

# 4 40 SERIES SPRING-LOADED CASTERS

## 500 LBS. LOAD CAPACITY CASTERS



SWIVEL CROSS SECTION

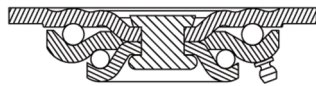

- **Load Springs:** Maximum rated capacity loads will deflect wheel approximately 3/8" (50%). Different load springs for each series permits wide variation in ride "softness." They can be preloaded to obtain various degrees of deflection
- **Top Plate & Yoke Base:** Made from 1/4" steel plate and unnotched
- **Swivel Section:** Cold formed, hardened double ball bearing raceways minimize ball indentation and wear
- **Legs:** 1/4" steel cold formed to increase strength and welded to the yoke base
- **King Bolt:** 5/8" diameter orbitally spun steel rivet
- **Axle:** 1/2" diameter hollow axle complete with lock nut. Axle is solid for 28 & 29 ball bearings
- **Wheel Seals:** Nylon seal retaining/thrust washers
- Alternate or custom caster configurations available

*Designed with the load in mind, the 40 series protects from damaging shocks or unwanted vibration and movement. Noise levels are reduced through the dampening effect of these casters.*

### MOUNTING

#### TOP PLATE: (STANDARD)

**Plate Size:** 4 x 4-1/2

**Bolt Holes:** 2-5/8 x 3-5/8  
slotted to 3 x 3

**Bolt Size:** 3/8

### RIG OPTIONS

<b>NS</b>	Neoprene Sealed Swivel Section
<b>ZF</b>	Hollow Axle
<b>SSB</b>	Single Side Brake
<b>DSB</b>	Double Side Brake
<b>SL</b>	Swivel Lock

### BRAKES OPTIONS

**Single Sided** and **Double Sided** Brakes available. Consult Factory

**Swivel Lock** available (welded) Consult Factory

### TYPICAL APPLICATIONS

- Aircraft tripod jacks
- Portable medical equipment
- Computer equipment
- Shock sensitive loads

### BEARING OPTIONS

Roller Bearing **(02)**

Industrial Ball **(27)**

Precision Ball **(28)**

# 4 40 SERIES SPRING-LOADED CASTERS

## X-TRA SOFT FLAT TREAD 29 PEDESTAL PRECISION XS

- Prevenz™ antimicrobial models available
- Add PREV to end of caster number
- Industrial Ball 27, Annular Ball 31 available
- Change "01" to other bearing code
- Industrial Ball example: 40XS05227



Part Number Swivel Caster	Part Number Rigid Caster	Wheel Diameter (inch)	Tread Width (inch)	Load Capacity (lbs)	Overall Height (inch)	Swivel Lead (inch)	Approx. Weight (lbs)
40XS05229S	40XS05229R	5	2	375	8	1-3/4	8
40XS06229S	40XS06229R	6	2	500	8-1/2	1-3/4	8-1/2
40XS08229S	40XS08229R	8	2	500	10-1/2	1-3/4	9-1/2

## POLYURETHANE ON POLYPROPYLENE 29 PEDESTAL PRECISION XA

Part Number Swivel Caster	Part Number Rigid Caster	Wheel Diameter (inch)	Tread Width (inch)	Load Capacity (lbs)	Overall Height (inch)	Swivel Lead (inch)	Approx. Weight (lbs)
40XA05229S	40XA05229R	5	2	500	8	1-3/4	8
40XA06229S	40XA06229R	6	2	500	8-1/2	1-3/4	8-3/4
40XA08229S	40XA08229R	8	2	500	10-1/2	1-3/4	9-1/2



## ELASTIC BLUE RUBBER BALL BEARING ERB

- Elastic solid rubber, smooth rolling quality
- Color Blue, 65° + 3° shore A
- Vulcanized, for non-detachable bond, low rolling resistance
- Made of aluminum die-cast, corrosion-resistant, with dual sealed precision ball bearings

Part Number Swivel Caster	Part Number Rigid Caster	Wheel Diameter (inch)	Tread Width (inch)	Load Capacity (lbs)	Overall Height (inch)	Swivel Lead (inch)	Approx. Weight (lbs)
40ERB06229S	40ERB06229R	6	2	660	7-1/2	1-3/4	6-1/2
40ERB08229S	40ERB08229R	8	2	800	9-1/2	1-3/4	7-1/2



# 4 40 SERIES SPRING-LOADED CASTERS

## POLYURETHANE ON ALUMINUM FLAT TREAD 29 PEDESTAL PRECISION

**PD**

Part Number Swivel Caster	Part Number Rigid Caster	Wheel Diameter (inch)	Tread Width (inch)	Load Capacity (lbs)	Overall Height (inch)	Swivel Lead (inch)	Approx. Weight (lbs)
40PD05229S	40PD05229R	5	2	500	8	1-3/4	9
40PD06229S	40PD06229R	6	2	500	8-1/2	1-3/4	8-3/4
40PD08229S	40PD08229R	8	2	500	10-1/2	1-3/4	10



## POLYURETHANE ON ALUMINUM ROUND TREAD 28 ROLLER BEARING

**PM**

Part Number Swivel Caster	Part Number Rigid Caster	Wheel Diameter (inch)	Tread Width (inch)	Load Capacity (lbs)	Overall Height (inch)	Swivel Lead (inch)	Approx. Weight (lbs)
40PM05228S	40PM05228R	5	2	500	8	1-3/4	11
40PM06228S	40PM06228R	6	2	500	8-1/2	1-3/4	12-1/2
40PM08228S	40PM08228R	8	2	500	10-1/2	1-3/4	13



## NYLACRON™ 29 PRECISION BALL BEARING

**NY/MD**

Part Number Swivel Caster	Part Number Rigid Caster	Wheel Diameter (inch)	Tread Width (inch)	Load Capacity (lbs)	Overall Height (inch)	Swivel Lead (inch)	Approx. Weight (lbs)
40NYMD05201S	40NYMD05201R	5	2	500	8	1-3/4	8
40NYMD06201S	40NYMD06201R	6	2	500	8-1/2	1-3/4	8-3/4
40NYMD08201S	40NYMD08201R	8	2	500	10-1/2	1-3/4	9-1/2

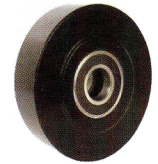

## NYLACRON™ WHITE 29 PRECISION BALL BEARING

**NY/MC**

Part Number Swivel Caster	Part Number Rigid Caster	Wheel Diameter (inch)	Tread Width (inch)	Load Capacity (lbs)	Overall Height (inch)	Swivel Lead (inch)	Approx. Weight (lbs)
40NYMC05228S	40NYMC05228R	5	2	500	8	1-3/4	8
40NYMC06228S	40NYMC06228R	6	2	500	8-1/2	1-3/4	8-3/4
40NYMC08228S	40NYMC08228R	8	2	500	10-1/2	1-3/4	9-1/2



# 4 100 SERIES PNEUMATIC CASTERS



## 300 LBS. LOAD CAPACITY CASTERS

- Double ball bearing swivel raceway
- Zinc plated standard
- Top plate and yoke 1/4" cold forged steel
- 5/8" riveted kingpin
- 1/2" diameter axle and lock nut
- Shock absorbing
- Grease fittings in swivel raceway
- Quiet rolling and easy moving
- Pneumatic flat free wheels

### RIG OPTIONS

- CS** Swivel
- CR** Rigid
- TS** Swivel/Top Lock Brake
- DSB** Double Side Brake
- SL** Swivel Lock

### BRAKES OPTIONS

**Single Side** and **Double Sided** Brakes available. Consult Factory.

**Swivel Lock** available (welded) Consult Factory.

*The 100 Series casters provides a smooth and easy movement. The grease fittings and 4-ply rubber pneumatics make the 100 Series perfect for carts, platform trucks, and more.*

### TYPICAL APPLICATIONS

- Platform Trucks
- Institutional
- Commercial
- Lawn and Garden

### MOUNTING

#### TOP PLATE: (STANDARD)

- Plate Size:** 4" x 4-1/2"
- Bolt Holes:** 2-5/8" x 3-5/8" slotted to 3" x 3"
- Bolt Size:** 3/8"

Part Number Swivel Caster	Part Number Rigid Caster	Part Number Top Lock	Wheel Diameter (inch)	Tread Width (inch)	Wheel Type	Load Capacity (inch)	Overall Height (inch)	Radius (inch)
100CS620FF4503	100CR620FF4503	100TS620FF4503	6	2	Flat-Free	250	7-1/2	4-1/2
100CS830FF4503	100CR830FF4503	100TS830FF4503	8	3	Flat-Free	300	9-3/4	6-1/2