



Caster Type	Page
-------------	------

2C Casters & Wheels.....	2-10
2CSS Stainless Casters & Wheels.....	10-16
US Top Plate P51.....	17-21
2E Plate & Stem Casters.....	22-23
2J Plate & Stem Casters.....	24-29
2SA Shock Absorbing Caster.....	30

Best Value Standard & **Stainless Steel** Institutional Casters for Every Application

- Food Service
 - Hotel & Catering Equipment
 - Kitchen Equipment
 - Movable Hi-tech Products
 - Institutional Equipment
- Pharmaceutical
 - Animal Cages
 - AALAS
 - Apparatus
 - Instrument Equipment Carts
- Hospital
 - Medical Equipment
 - Laboratories
 - Clean Room
 - Movable Furniture

POLISHED CHROME pressed steel double ballrace swivel yoke

POLISHED STAINLESS STEEL pressed steel double ballrace swivel yoke

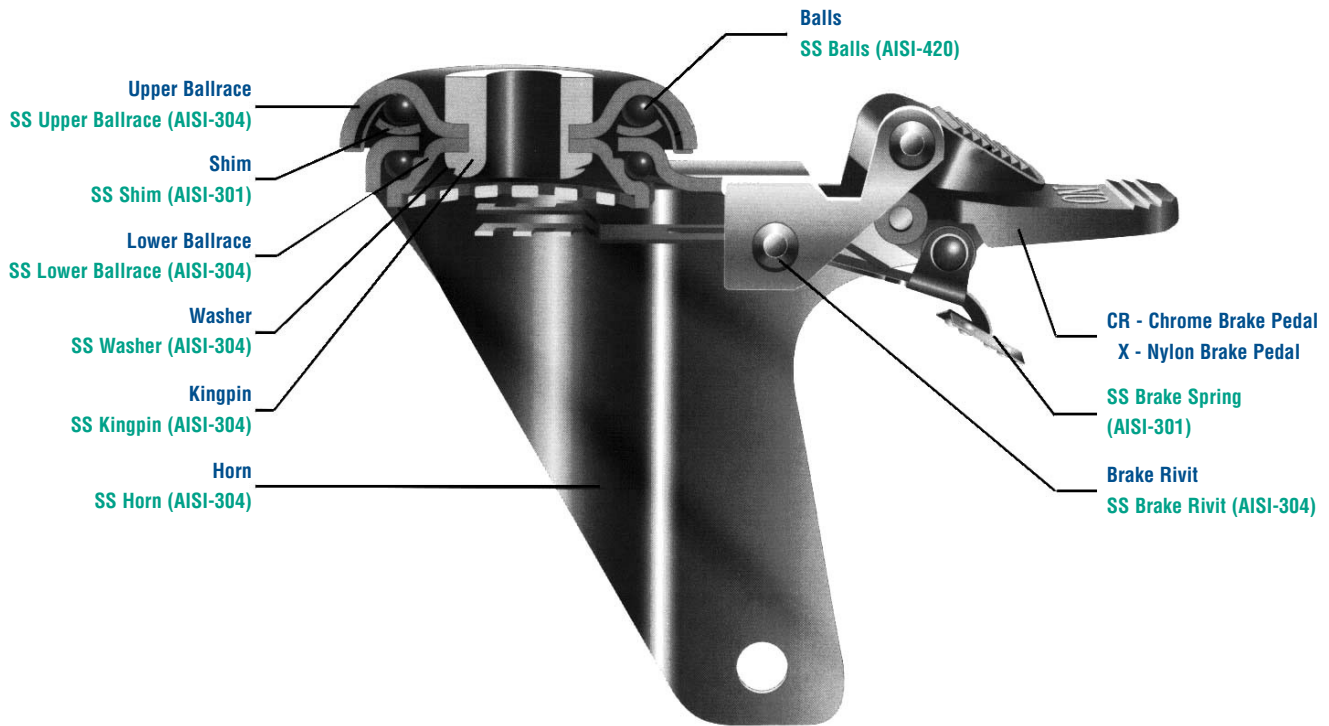

AXLE & NUT STANDARD STEEL/AXLE & NUT STAINLESS STEEL

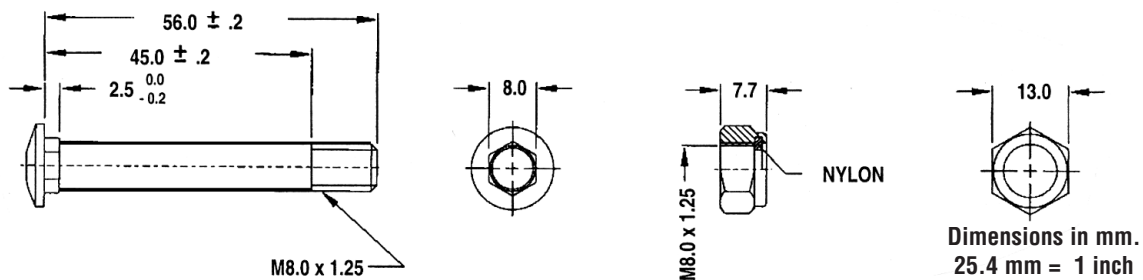

2 2C STANDARD OPTIONS



Swivel Caster



Rigid Caster



Swivel Caster with Total Lock

FEATURES

Load Capacity

Up to 275 lbs.

- Polished chrome, Pressed Steel Housing
- Pressed Steel Double Ball Race with Hardened Main Ball Raceway Shim and Hardened Steel Balls functions as Kingpinless construction to give longer life
- Metal Brake Pedal Available with nylon or rubber brake pedal
- No Rust

SWIVEL RIG OPTIONS

- TLB** Total Lock Brake
- STG** Steel Thread Guards
- H3** Hole Casters (Swivel, Rigid or Total Lock)
- DL** Directional Lock
- X** Nylon Brake Pedal

SWIVEL TOP PLATES (Dimensions are in mm. 25.4mm = 1in)

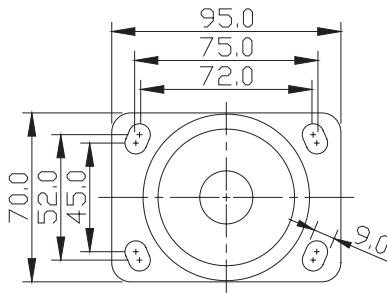

P1

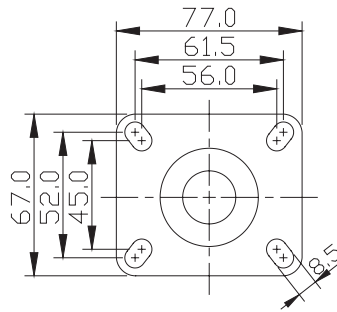

P2

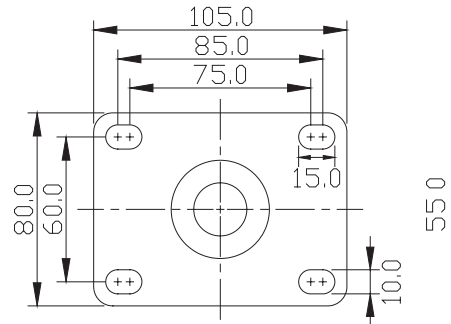

P3

RIGID TOP PLATES (Dimensions are in mm. 25.4mm = 1in)

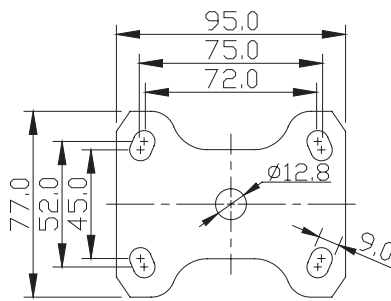

P1

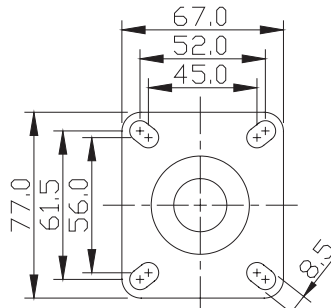

P2

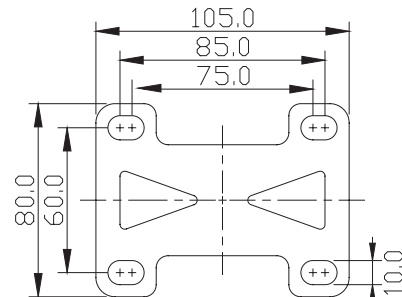

P3

GRIP RING STEM OPTIONS GR

Stem Code	Stem Dimensions
GR1	3/4" diameter x 2-3/16" long
GR2	13/16" diameter x 2-3/16" long
GR3	.845" diameter x 2-3/16" long
GR4	.865" diameter x 2-3/16" long
GR5	1" diameter x 2-3/16" long
GR6	.860" square x 2-3/16" long

THREADED STEM OPTIONS TS

Stem Code	Stem Dimensions
TS1	1/2"-13 x 3/4" long
TS2	1/2"-13 x 1" long
TS3	1/2"-13 x 1-1/2" long
TS4	1/2"-20 x 3/4" long
TS5	1/2"-20 x 2-1/4" long
TS6	5/8"-11 x 1-1/4" long
TS7	5/8"-18 x 1-3/4" long
TS8	3/4"-10 x 1" long

PIPE THREAD STEM OPTIONS PS

Stem Code	Stem Dimensions
PS1	1/2" Pipe Thread (3/4" actual stem dia.)
PS2	3/4" Pipe Thread (1" actual stem dia.)
PS3	1" Pipe Thread (1-1/4" actual stem dia.)
PS4	1-1/4" Pipe Thread (1-1/2" actual stem dia.)

**OTHER SPECIAL STEMS AVAILABLE,
STANDARD OR STAINLESS STEEL.**

EXPANDING ADAPTER STEMS ES

Adapter #	Tubing ID	Adapter #	Tubing ID
ES9	3/4"	ES17B	1-3/16"
ES11	7/8"	ES19C	1-3/8"
ES13	1"	ES19A	1-1/2"
ES15	1-1/8"	ES21	1-7/8"

Rubber bushing expands inside of tubing as 3/4" nut beneath lower raceway is turned with wrench. Plastic bushing on bottom of stem provides stability for stem inside of tubing for tight, permanent fit. Threaded stem size (less adapter): 1/2" dia. x 2-3/4" long. To order, add adapter number to end of model #.

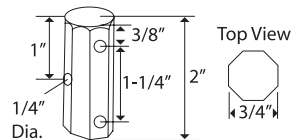
**2-PZC OCTAGON STEM OC****Standard Octagon Stem Size: OC**

3/4" octagon 2" long with 3 cross-drilled mounting holes.

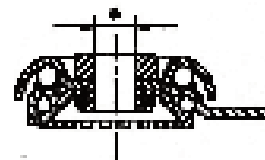

Hole Type

2-PZC HOLLOW KINGPIN H3**Mounting Options: H3**

Diameter: 12.8 mm.

Bolt Size: 1/2"

**SPECIFY ALL OPTIONS IN THE SUFFIX OF
THE PART NUMBER.**

**EXAMPLE: TS1 AT THE END
OF THE CASTER NUMBER.**

KR
WHEELS

KRYPTONIC™ WHEELS

- Polyether Polyurethane has excellent carrying capacity.
- Crown shape affords an easy-rolling quiet operation.
- Greater service life and resistance to chunking, cutting and abrasive wear.

- 100% washable, steam cleanable, and resistant to most chemicals.
- Non-marking tread.
- Durometer: 58 Shore D (+/-5).
- Stainless Steel Precision Ball Bearings.
- Temperature Range: +250°F for up to 2 hours.
- Available in 5" gray +250°F for 5 to 6 hours.



Part Number Swivel with Total Lock	Part Number Swivel Caster	Part Number Rigid Caster	Wheel Diameter (inch)	Tread Width (inch)	Load Capacity (lbs)	Overall Height (mm)	Swivel Radius (mm)
2CKR3TL	2CKR3S	2CKR3R	3	1-1/4	300	107	33
2CKR4TL	2CKR4S	2CKR4R	4	1-1/4	300	135	40.5
2CKR5TL	2CKR5S	2CKR5R	5	1-1/4	300	161	39

ANR
WHEELS

ADVANCED RED RUBBER

- 80 (+5) Shore (A).
- Unique soft tread wheel handles the heat for autoclave applications.
- Roll quiet and smooth ride.

- Recommended for use in hospitals, laboratories and cleanrooms.
- Corrosion resistant thermoplastics.
- Resilient tread material rejects floor debris.
- Stainless Steel Precision Ball Bearings.
- Temp Range: -190°F to +300°F.



Part Number Swivel with Total Lock	Part Number Swivel Caster	Part Number Rigid Caster	Wheel Diameter (inch)	Tread Width (inch)	Load Capacity (lbs)	Overall Height (mm)	Swivel Radius (mm)
2CANR4TL	2CANR4S	2CANR4R	4	1-1/4	175	135	40.5
2CANR5TL	2CANR5S	2CANR5R	5	1-1/4	220	161	39
2CANR6TL	2CANR6S	2CANR6R	6	1-1/4	245	167	45

RT
WHEELS

RETORT

- 75 Durometer Shore (D).
- Designed to withstand the rigors of high temperature.

- Oversized bore ID ensures smooth movement.
- Moderate crown/White finish.
- Temp Range: -20°F to +290°F.



Part Number Swivel with Total Lock	Part Number Swivel Caster	Part Number Rigid Caster	Wheel Diameter (inch)	Tread Width (inch)	Load Capacity (lbs)	Overall Height (mm)	Swivel Radius (mm)
2CRT3TL	2CRT3S	2CRT3R	3	1-1/4	130	107	33
2CRT4TL	2CRT4S	2CRT4R	4	1-1/4	175	135	40.5
2CRT5TL	2CRT5S	2CRT5R	5	1-1/4	220	161	39

TPR
WHEELS

THERMOPLASTIC GRAY TREAD RUBBER PLASTIC HUB.

- 70 (+/-5) Durometer Shore (A).
- Recommended for clean environments.

- Resists most solvents, oil, grease, and water.
- Non-marking.
- Smooth rolling and quiet.
- Precision Ball Bearings.
- Temp Range: -45°F to +180°F.



Part Number Swivel with Total Lock	Part Number Swivel Caster	Part Number Rigid Caster	Wheel Diameter (inch)	Tread Width (inch)	Load Capacity (lbs)	Overall Height (mm)	Swivel Radius (mm)
2CTPR3TL	2CTPR3S	2CTPR3R	3	1-1/4	130	107	33
2CTPR4TL	2CTPR4S	2CTOR4R	4	1-1/4	175	135	40.5
2CTPR5TL	2CTPR5S	2CTOR5R	5	1-1/4	220	161	39

**PRB
WHEELS****ELASTIC RUBBER**

- Plastic hub material.
- Plastic 3" & Steel 4" & 5" thread guards.
- Gray color elastic rubber tire material.
- Precision Ball Bearings.
- Short-term temperature range: -40°/80°C.

Part Number Swivel with Total Lock	Part Number Swivel Caster	Part Number Rigid Caster	Wheel Diameter (inch)	Tread Width (inch)	Load Capacity (lbs)	Overall Height (mm)
2CPRB3TL	2CPRB3S	2CPRB3R	3	1-1/4	110	107
2CPRB4TL	2CPRB4S	2CPRB4R	4	1-1/4	175	135
2CPRB5TL	2CPRB5S	2CPRB5R	5	1-1/4	220	161

**SRB
WHEELS****ELASTIC RUBBER**

- Pressed steel hub material.
- Steel thread guards.
- Gray color elastic rubber tire material.
- Precision Ball Bearings.
- Short-term temperature range: -40°/80°C.

Part Number Swivel with Total Lock	Part Number Swivel Caster	Part Number Rigid Caster	Wheel Diameter (inch)	Tread Width (inch)	Load Capacity (lbs)	Overall Height (mm)
2CSR4TL	2CSR4S	2CSR4R	4	1-1/4	175	135
2CSR5TL	2CSR5S	2CSR5R	5	1-1/4	220	161
2CSR6TL	2CSR6S	2CSR6R	6	1-1/4	220	190

**PM
WHEELS****SOLID NYLON**

- Steel thread guards.
- White color.
- Roller Bearings.
- Short-term temperature range: -30°/+120°C.

Part Number Swivel with Total Lock	Part Number Swivel Caster	Part Number Rigid Caster	Wheel Diameter (inch)	Tread Width (inch)	Load Capacity (lbs)	Overall Height (mm)
2CPM3TL	2CPM3S	2CPM3R	3	1-1/4	110	107
2CPM4TL	2CPM4S	2CPM4R	4	1-1/4	175	135
2CPM5TL	2CPM5S	2CPM5R	5	1-1/4	220	161

2

2C POLISHED CHROME FINISH PLATE CASTERS

TPR/AS WHEELS

ANTI-STATIC PLASTIC HUB, GRAY COLOR CONDUCTIVE THERMOPLASTIC RUBBER TREAD

- 70 (+/-5) Durometer Shore (A).
- Anti-static plastic hub.

- Non-marking.
- Easy rolling, impact resistant and shock absorbing.
- Precision Ball Bearings.
- Temp Range: -40°F to +120°F.



Part Number Swivel with Total Lock	Part Number Swivel Caster	Part Number Rigid Caster	Wheel Diameter (inch)	Tread Width (inch)	Load Capacity (lbs)	Overall Height (mm)	Swivel Radius (mm)
2CAS4TL	2CAS4S	2CAS4R	4	1-1/4	175	135	40.5
2CAS5TL	2CAS5S	2CAS5R	5	1-1/4	220	161	39
2CAS6TL	2CAS6S	2CAS6R	6	1-1/4	240	190	50

TPU WHEELS

PLASTIC HUB, GRAY COLOR POLYURETANE TREAD

- 95 (+/-5) Durometer Shore (A).
- Plastic hub.

- Non-marking.
- High impact and abrasion resistant.
- Precision Ball Bearings.
- Temp Range: -40°F to +180°F.



Part Number Swivel with Total Lock	Part Number Swivel Caster	Part Number Rigid Caster	Wheel Diameter (inch)	Tread Width (inch)	Load Capacity (lbs)	Overall Height (mm)	Swivel Radius (mm)
2CTPU3TL	2CTPU3S	2CTPU3R	3	1-1/4	110	107	40.5
2CTPU4TL	2CTPU4S	2CTPU4R	4	1-1/4	175	135	39
2CTPU5TL	2CTPU5S	2CTPU5R	5	1-1/4	220	161	45

*steel tread guard

P1, P2, P3 for Swivel Plate Sizes
TL for Total Lock to Swivel Caster

P4, P5, or P6 for Rigid Plate Sizes
DL for Directional Lock

All wheels with precision ball bearings
H3 for Hole Caster

NOTE: All load ratings are for manual operation.

OTHER TYPE 1 1/4" WHEELS AVAILABLE FOR THIS SERIES.

NYLACRON™ MD (NY/MD), NYLACRON™ MONOCAST (NY/MC), SOLID NYLON (PM), HIGH TEMP WHEELS AVAILABLE. SEE WHEEL SECTION.

KR
WHEELS

KRYPTONIC™ WHEELS

- Polyether Polyurethane has excellent carrying capacity.
- Crown shape affords an easy-rolling quiet operation.
- Greater service life and resistance to chunking, cutting and abrasive wear.

- 100% washable, steam cleanable, and resistant to most chemicals.
- Non-marking tread.
- Durometer: 58 Shore D (+/-5).
- Stainless Steel Precision Ball Bearings.
- Temperature Range: + 250°F for up to 2 hours.
- **Available in 5" gray + 250°F for 5 to 6 hours.**



Part Number Swivel with Total Lock	Part Number Swivel Caster	Wheel Diameter (inch)	Tread Width (inch)	Load Capacity (lbs)	Overall Height (mm)	Swivel Radius (mm)
2CKR3TLH3	2CKR3SH3	3	1-1/4	300	107	33
2CKR4TLH3	2CKR4SH3	4	1-1/4	300	135	40.5
2CKR5TLH3	2CKR5SH3	5	1-1/4	300	161	39

ANR
WHEELS

ADVANCED RED RUBBER

- 80 (+/-5) Shore (A).
- Unique soft tread wheel handles the heat for autoclave applications.
- Roll quiet and smooth ride.

- Recommended for use in hospitals, laboratories and cleanrooms.
- Corrosion resistant thermoplastics.
- Resilient tread material rejects floor debris.
- Stainless Steel Precision Ball Bearings.
- Temp Range: -190°F to +300°F.



Part Number Swivel with Total Lock	Part Number Swivel Caster	Wheel Diameter (inch)	Tread Width (inch)	Load Capacity (lbs)	Overall Height (mm)	Swivel Radius (mm)
2CANR4TLH3	2CANR4SH3	4	1-1/4	175	135	40.5
2CANR5TLH3	2CANR5SH3	5	1-1/4	220	161	39
2CANR6TLH3	2CANR6SH3	6	1-1/4	245	167	45

RT
WHEELS

RETORT

- 75 Durometer Shore (D).
- Designed to withstand the rigors of high temperature.

- Oversized bore ID ensures smooth movement.
- Moderate crown/White finish.
- Precision Ball Bearings.
- Temp Range: -20°F to +290°F.



Part Number Swivel with Total Lock	Part Number Swivel Caster	Wheel Diameter (inch)	Tread Width (inch)	Load Capacity (lbs)	Overall Height (mm)	Swivel Radius (mm)
2CRT3TLH3	2CRT3SH3	3	1-1/4	130	107	33
2CRT4TLH3	2CRT4SH3	4	1-1/4	175	135	40.5
2CRT5TLH3	2CRT5SH3	5	1-1/4	220	161	39

TPR
WHEELS

THERMOPLASTIC GRAY TREAD RUBBER PLASTIC HUB.

- 70 (+/-5) Durometer Shore (A).
- Recommended for clean environments.

- Resists most solvents, oil, grease, and water.
- Non-marking.
- Smooth rolling and quiet.
- Precision Ball Bearings.
- Temp Range: -45°F to +180°F.



Part Number Swivel with Total Lock	Part Number Swivel Caster	Wheel Diameter (inch)	Tread Width (inch)	Load Capacity (lbs)	Overall Height (mm)	Swivel Radius (mm)
2CTPR3TLH3	2CTPR3SH3	3	1-1/4	130	107	33
2CTPR4TLH3	2CTPR4SH3	4	1-1/4	175	135	40.5
2CTPR5TLH3	2CTPR5SH3	5	1-1/4	220	161	39

**PRB
WHEELS****ELASTIC RUBBER**

- Plastic hub material.
- Plastic 3" & Steel 4" & 5" thread guards.
- Gray color elastic rubber tire material.
- Precision Ball Bearings.
- Short-term temperature range: -40°/80°C.

Part Number Swivel with Total Lock	Part Number Swivel Caster	Wheel Diameter (inch)	Tread Width (inch)	Load Capacity (lbs)	Overall Height (mm)
2CPRB3TLH3	2CPRB3SH3	3	1-1/4	110	107
2CPRB4TLH3	2CPRB4SH3	4	1-1/4	175	135
2CPRB5TLH3	2CPRB5SH3	5	1-1/4	220	161

**SRB
WHEELS****ELASTIC RUBBER**

- Pressed steel hub material.
- Steel thread guards.
- Gray color elastic rubber tire material.
- Precision Ball Bearings.
- Short-term temperature range: -40°/80°C.

Part Number Swivel with Total Lock	Part Number Swivel Caster	Wheel Diameter (inch)	Tread Width (inch)	Load Capacity (lbs)	Overall Height (mm)
2CSR4TLH3	2CSR4SH3	4	1-1/4	175	135
2CSR5TLH3	2CSR5SH3	5	1-1/4	220	161
2CSR6TLH3	2CSR6SH3	6	1-1/4	220	190

**PM
WHEELS****SOLID NYLON**

- Steel thread guards.
- White color.
- Roller Bearings.
- Short-term temperature range: -30°/+120°C.

Part Number Swivel with Total Lock	Part Number Swivel Caster	Wheel Diameter (inch)	Tread Width (inch)	Load Capacity (lbs)	Overall Height (mm)
2CPM3TLH3	2CPM3SH3	3	1-1/4	110	107
2CPM4TLH3	2CPM4SH3	4	1-1/4	175	135
2CPM5TLH3	2CPM5SH3	5	1-1/4	220	161

**ANTI-STATIC PLASTIC HUB,
GRAY COLOR CONDUCTIVE THERMOPLASTIC
RUBBER TREAD**

- 70 (+/-5) Durometer Shore (A).
- Anti-static plastic hub.

- Non-marking.
- Easy rolling, impact resistant and shock absorbing.
- Precision Ball Bearings.
- Temp Range: -40°F to +120°F.



Part Number Swivel with Total Lock	Part Number Swivel Caster	Wheel Diameter (inch)	Tread Width (inch)	Load Capacity (lbs)	Overall Height (mm)	Swivel Radius (mm)
2CAS4TLH3	2CAS4SH3	4	1-1/4	175	135	40.5
2CAS5TLH3	2CAS5SH3	5	1-1/4	220	161	39
2CAS6TLH3	2CAS6SH3	6	1-1/4	240	189.5	50

**PLASTIC HUB, GRAY COLOR
POLYURETANE TREAD**

- 95 (+/-5) Durometer Shore (A).
- Plastic hub.

- Non-marking.
- High impact and abrasion resistant.
- Temp Range: -40°F to +180°F.



Part Number Swivel with Total Lock	Part Number Swivel Caster	Wheel Diameter (inch)	Tread Width (inch)	Load Capacity (lbs)	Overall Height (mm)	Swivel Radius (mm)
2CTPU4TLH3	2CTPU4SH3	3	1-1/4	110	107	40.5
2CTPU5TLH3	2CTPU5SH3	4	1-1/4	175	135	39
2CTPU6TLH3	2CTPU6SH3	5	1-1/4	220	161	45

*steel tread guard

*P1, P2, P3 for Swivel Plate Sizes

P4, P5, or P6 for Rigid Plate Sizes

All wheels with precision ball bearings

**TL for Total Lock to Swivel Caster

DL for Directional Lock

H3 for Hole Caster

NOTE: All load ratings are for manual operation.

OTHER TYPE 1 1/4" WHEELS AVAILABLE FOR THIS SERIES: IE, ELASTIC RUBBER: WHITE NYLON

NYLACRON™ MD (NY/MD), NYLACRON™ MONOCAST (NY/MC), HIGH TEMP WHEELS AVAILABLE. SEE WHEEL SECTION.

2

2CSS POLISHED STAINLESS STEEL PLATE CASTERS

KR WHEELS

KRYPTONIC™ WHEELS

- Polyether Polyurethane has excellent carrying capacity.
- Crown shape affords an easy-rolling quiet operation.
- Greater service life and resistance to chunking, cutting and abrasive wear.

- 100% washable, steam cleanable, and resistant to most chemicals.
- Non-marking tread.
- Durometer: 58 Shore D (+/-5).
- Stainless Steel Precision Ball Bearings.
- Temperature Range: + 250°F for up to 2 hours.
- Available in 5" gray + 250°F for 5 to 6 hours.



Part Number Swivel with Total Lock	Part Number Swivel Caster	Part Number Rigid Caster	Wheel Diameter (inch)	Tread Width (inch)	Load Capacity (lbs)	Overall Height (mm)	Swivel Radius (mm)
2CSSKR3TL	2CSSKR3S	2CSSKR3R	3	1-1/4	130	107	33
2CSSKR4TL	2CSSKR4S	2CSSKR4R	4	1-1/4	175	135	40.5
2CSSKR5TL	2CSSKR5S	2CSSKR5R	5	1-1/4	220	161	39

ANR WHEELS

ADVANCED RED RUBBER

- 80 (+/-5) Shore (A).
- Unique soft tread wheel handles the heat for autoclave applications.
- Roll quiet and smooth ride.

- Recommended for use in hospitals, laboratories and cleanrooms.
- Corrosion resistant thermoplastics.
- Resilient tread material rejects floor debris.
- Stainless Steel Precision Ball Bearings.
- Temp Range: -190°F to +300°F.



Part Number Swivel with Total Lock	Part Number Swivel Caster	Part Number Rigid Caster	Wheel Diameter (inch)	Tread Width (inch)	Load Capacity (lbs)	Overall Height (mm)	Swivel Radius (mm)
2CSSANR4TL	2CSSANR4S	2CSSANR4R	4	1-1/4	175	135	40.5
2CSSANR5TL	2CSSANR5S	2CSSANR5R	5	1-1/4	220	161	39
2CSSANR6TL	2CSSANR6S	2CSSANR6R	6	1-1/4	245	167	45

RT WHEELS

RETORT

- 75 Durometer Shore (D).
- Designed to withstand the rigors of high temperature.

- Oversized bore ID ensures smooth movement.
- Moderate crown/White finish.
- Stainless Steel Precision Ball Bearings.
- Temp Range: -20°F to +290°F.



Part Number Swivel with Total Lock	Part Number Swivel Caster	Part Number Rigid Caster	Wheel Diameter (inch)	Tread Width (inch)	Load Capacity (lbs)	Overall Height (mm)	Swivel Radius (mm)
2CSSRT3TL	2CSSRT3S	2CSSRT3R	3	1-1/4	130	107	33
2CSSRT4TL	2CSSRT4S	2CSSRT4R	4	1-1/4	175	135	40.5
2CSSRT5TL	2CSSRT5S	2CSSRT5R	5	1-1/4	220	161	39

**PRB
WHEELS****ELASTIC RUBBER**

- Plastic hub material.
- Plastic 3" & Steel 4" & 5" thread guards.
- Gray color elastic rubber tire material.
- Stainless Steel Precision Ball Bearings.
- Short-term temperature range: -40°/80°C.

Part Number Swivel with Total Lock	Part Number Swivel Caster	Part Number Rigid Caster	Wheel Diameter (inch)	Tread Width (inch)	Load Capacity (lbs)	Overall Height (mm)
2CSSPRB3TL	2CSSPRB3S	2CSSPRB3R	3	1-1/4	110	107
2CSSPRB4TL	2CSSPRB4S	2CSSPRB4R	4	1-1/4	175	135
2CSSPRB5TL	2CSSPRB5S	2CSSPRB5R	5	1-1/4	220	161

**SRB
WHEELS****ELASTIC RUBBER**

- Pressed steel hub material.
- Steel thread guards.
- Gray color elastic rubber tire material.
- Stainless Steel Precision Ball Bearings.
- Short-term temperature range: -40°/80°C.

Part Number Swivel with Total Lock	Part Number Swivel Caster	Part Number Rigid Caster	Wheel Diameter (inch)	Tread Width (inch)	Load Capacity (lbs)	Overall Height (mm)
2CSSSRB4TL	2CSSSRB4S	2CSSSRB4R	4	1-1/4	175	135
2CSSSRB5TL	2CSSSRB5S	2CSSSRB5R	5	1-1/4	220	161
2CSSSRB6TL	2CSSSRB6S	2CSSSRB6R	6	1-1/4	220	190

**PM
WHEELS****SOLID NYLON**

- Steel thread guards.
- White color.
- Stainless Steel Roller Bearings.
- Short-term temperature range: -30°/+120°C.

Part Number Swivel with Total Lock	Part Number Swivel Caster	Part Number Rigid Caster	Wheel Diameter (inch)	Tread Width (inch)	Load Capacity (lbs)	Overall Height (mm)
2CSSPM3TL	2CSSPM3S	2CSSPM3R	3	1-1/4	110	107
2CSSPM4TL	2CSSPM4S	2CSSPM4R	4	1-1/4	175	135
2CSSPM5TL	2CSSPM5S	2CSSPM5R	5	1-1/4	220	161

2

2CSS POLISHED STAINLESS STEEL PLATE CASTERS

TPR SS WHEELS

THERMOPLASTIC GRAY TREAD RUBBER PLASTIC HUB WITH PLASTIC THREAD GUARD

- 70 (+/-5) Durometer Shore (A).
- Recommended for clean environments.

- Resists most solvents, oil, grease, and water.
- Non-marking.
- Smooth rolling and quiet.
- Stainless Steel Precision Ball Bearings.
- Temp Range: -45°F to +180°F.



Part Number Swivel with Total Lock	Part Number Swivel Caster	Part Number Rigid Caster	Wheel Diameter (inch)	Tread Width (inch)	Load Capacity (lbs)	Overall Height (mm)	Swivel Radius (mm)
2CSSTPR4TL	2CSSTPR4S	2CSSTPR4R	4	1-1/4	130	107	33
2CSSTPR5TL	2CSSTPR5S	2CSSTPR5R	5	1-1/4	175	135	40.5
2CSSTPR4TL*	2CSSTPR4S*	2CSSTPR4R*	4	1-1/4	130	107	33
2CSSTPR5TL*	2CSSTPR5S*	2CSSTPR5R*	5	1-1/4	175	135	40.5

*stainless steel thread guard

HE WHEELS

HEATEATER

- 85 Durometer Shore (D +5).
- Ideal for specialty applications.
- Nylon Glass-filled wheels won't chip, absorb water, or breakdown in caustic environments.

- Temp Range: Up to 550°F, 475°F intermittent consult Acorn™.
- Stainless Steel Precision Ball Bearings.
- Moderate crown/Black finish.



Part Number Swivel with Total Lock	Part Number Swivel Caster	Part Number Rigid Caster	Wheel Diameter (inch)	Tread Width (inch)	Load Capacity (lbs)	Overall Height (mm)	Swivel Radius (mm)
2CSSHE3TL	2CSSHE3S	2CSSHE3R	3	1-1/4	110	135	40.5
2CSSHE4TL	2CSSHE4S	2CSSHE4R	4	1-1/4	175	161	39
2CSSHE5TL	2CSSHE5S	2CSSHE5R	5	1-1/4	220	167	45

URN WHEELS

URETHANE WHEEL WITH NYLON CORE

- 96 Shore (A).
- Urethane tread on a nylon core.
- Non-marking.

- Smooth rolling and quiet.
- Stainless Steel Precision Ball Bearings.
- Temp Range: -3°F to +212°F.



Part Number Swivel with Total Lock	Part Number Swivel Caster	Part Number Rigid Caster	Wheel Diameter (inch)	Tread Width (inch)	Load Capacity (lbs)	Overall Height (mm)	Swivel Radius (mm)
2CSSURN4TL	2CSSURN4S	2CSSURN4R	4	1-1/4	130	107	33
2CSSURN5TL	2CSSURN5S	2CSSURN5R	5	1-1/4	220	135	40.5
2CSSURN6TL	2CSSURN6S	2CSSURN6R	6	1-1/4	275	161	39

P1, P2, P3 for Swivel Plate Sizes
TL for Total Lock to Swivel Caster

P4, P5, or P6 for Rigid Plate Sizes
DL for Directional Lock

All wheels with precision ball bearings
H3 for Hole Caster

NOTE: All load ratings are for manual operation.

OTHER TYPE 1 1/4" WHEELS AVAILABLE FOR THIS SERIES:

NYLACRON™ MD (NY/MD), NYLACRON™ MONOCAST (NY/MC), SOLID NYLON (PM), HIGH TEMP WHEELS AVAILABLE. SEE WHEEL SECTION.

**KR
WHEELS****KRYPTONIC™ WHEELS**

- Polyether Polyurethane has excellent carrying capacity.
- Crown shape affords an easy-rolling quiet operation.
- Greater service life and resistance to chunking, cutting and abrasive wear.

- 100% washable, steam cleanable, and resistant to most chemicals.
- Non-marking tread.
- Durometer: 58 Shore D (+/-5).
- Stainless Steel Precision Ball Bearings.
- Temperature Range: + 250°F for up to 2 hours.
- **Available in 5" gray + 250°F for 5 to 6 hours.**



Part Number Swivel with Total Lock	Part Number Swivel Caster	Wheel Diameter (inch)	Tread Width (inch)	Load Capacity (lbs)	Overall Height (mm)	Swivel Radius (mm)
2CSSKR3TLH3	2CSSKR3SH3	3	1-1/4	300	107	33
2CSSKR4TLH3	2CSSKR4SH3	4	1-1/4	300	135	40.5
2CSSKR5TLH3	2CSSKR5SH3	5	1-1/4	300	161	39

**ANR
WHEELS****ADVANCED RED RUBBER**

- 80 (+/-5) Shore (A).
- Unique soft tread wheel handles the heat for autoclave applications.
- Roll quiet and smooth ride.

- Recommended for use in hospitals, laboratories and cleanrooms.
- Corrosion resistant thermoplastics.
- Resilient tread material rejects floor debris.
- Stainless Steel Precision Ball Bearings.
- Temp Range: -190°F to +300°F.



Part Number Swivel with Total Lock	Part Number Swivel Caster	Wheel Diameter (inch)	Tread Width (inch)	Load Capacity (lbs)	Overall Height (mm)	Swivel Radius (mm)
2CSSANR4TLH3	2CSSANR4SH3	4	1-1/4	175	135	40.5
2CSSANR5TLH3	2CSSANR5SH3	5	1-1/4	220	161	39
2CSSANR6TLH3	2CSSANR6SH3	6	1-1/4	245	167	45

**RT
WHEELS****RETORT**

- 75 Durometer Shore (D).
- Designed to withstand the rigors of high temperature.

- Oversized bore ID ensures smooth movement.
- Moderate crown/white finish.
- Stainless Steel Precision Ball Bearings.
- Temp Range: -20°F to +290°F.



Part Number Swivel with Total Lock	Part Number Swivel Caster	Wheel Diameter (inch)	Tread Width (inch)	Load Capacity (lbs)	Overall Height (mm)	Swivel Radius (mm)
2CSSRT3TLH3	2CSSRT3TLH3	3	1-1/4	130	107	33
2CSSRT4TLH3	2CSSRT4TLH3	4	1-1/4	175	135	40.5
2CSSRT5TLH3	2CSSRT5TLH3	5	1-1/4	220	161	39

2

2CSS POLISHED STAINLESS STEEL H3 HOLE CASTERS

PRB WHEELS

ELASTIC RUBBER

- Plastic hub material.
- Plastic 3" & Steel 4" & 5" thread guards.
- Gray color elastic rubber tire material.
- Stainless Steel Precision Ball Bearings.
- Short-term temperature range: -40°/80°C.

Part Number Swivel with Total Lock	Part Number Swivel Caster	Wheel Diameter (inch)	Tread Width (inch)	Load Capacity (lbs)	Overall Height (mm)
2CSSPRB3TLH3	2CSSPRB3SH3	3	1-1/4	110	107
2CSSPRB4TLH3	2CSSPRB4SH3	4	1-1/4	175	135
2CSSPRB5TLH3	2CSSPRB5SH3	5	1-1/4	220	161

PM WHEELS

SOLID NYLON

- Steel thread guards.
- White color.
- Stainless Steel Roller Bearings.
- Short-term temperature range: -30°/+120°C.

Part Number Swivel with Total Lock	Part Number Swivel Caster	Part Number Rigid Caster	Wheel Diameter (inch)	Tread Width (inch)	Load Capacity (lbs)	Overall Height (mm)
2CSSPM3TLH3	2CSSPM3SH3	2CSSPM3RH3	3	1-1/4	110	107
2CSSPM4TLH3	2CSSPM4SH3	2CSSPM4RH3	4	1-1/4	175	135
2CSSPM5TLH3	2CSSPM5SH3	2CSSPM5RH3	5	1-1/4	220	161

2

2CSS POLISHED STAINLESS STEEL H3 HOLE CASTERS

TPR SS WHEELS

**THERMOPLASTIC GRAY TREAD
RUBBER PLASTIC HUB WITH
PLASTIC THREAD GUARD**

- 70 (+/-5) Durometer Shore (A).
- Recommended for clean environments.

- Resists most solvents, oil, grease, and water.
- Non-marking.
- Smooth rolling and quiet.
- Stainless Steel Precision Ball Bearings.
- Temp Range: -45°F to +180°F.

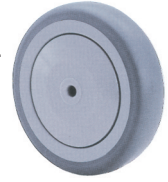

Part Number Swivel with Total Lock	Part Number Swivel Caster	Wheel Diameter (inch)	Tread Width (inch)	Load Capacity (lbs)	Overall Height (mm)	Swivel Radius (mm)
2CSSTPR4TLH3	2CSSTPR4SH3	4	1-1/4	130	107	33
2CSSTPR5TLH3	2CSSTPR5SH3	5	1-1/4	175	135	40.5
2CSSTPR4TLH3	2CSSTPR4SH3	4	1-1/4	130	107	33
2CSSTPR5TLH3	2CSSTPR5SH3	5	1-1/4	175	135	40.5

*stainless steel thread guard

HE WHEELS

HEATEATER

- 85 Durometer Shore (D +5).
- Ideal for specialty applications.
- Nylon Glass-filled wheels won't chip, absorb water, or breakdown in caustic environments.

- Temp Range: Up to 550°F, 475°F intermittent consult Acorn™.
- Stainless Steel Precision Ball Bearings.
- Moderate crown/black finish.



Part Number Swivel with Total Lock	Part Number Swivel Caster	Wheel Diameter (inch)	Tread Width (inch)	Load Capacity (lbs)	Overall Height (mm)	Swivel Radius (mm)
2CSSHE3TLH3	2CSSHE3SH3	3	1-1/4	110	135	40.5
2CSSHE4TLH3	2CSSHE4SH3	4	1-1/4	175	161	39
2CSSHE5TLH3	2CSSHE5SH3	5	1-1/4	220	167	45

P1, P2, P3 for Swivel Plate Sizes

P4, P5, or P6 for Rigid Plate Sizes

All wheels with precision ball bearings

TL for Total Lock to Swivel Caster

DL for Directional Lock

H3 for Hole Caster

NOTE: All load ratings are for manual operation.

OTHER TYPE 1 1/4" WHEELS AVAILABLE FOR THIS SERIES:

NYLACRON™ MD (NY/MD), NYLACRON™ MONOCAST (NY/MC), SOLID NYLON (PM), HIGH TEMP WHEELS AVAILABLE. SEE WHEEL SECTION.

2C POLISHED CHROME FINISH PLATE CASTERS US TOP PLATE P51

POLISHED CHROME
pressed steel double ballrace
swivel yoke with hardened shim

POLISHED STAINLESS STEEL
pressed steel double ballrace
swivel yoke

See category 2C Series
in our catalog for other
plate sizes and wheels.

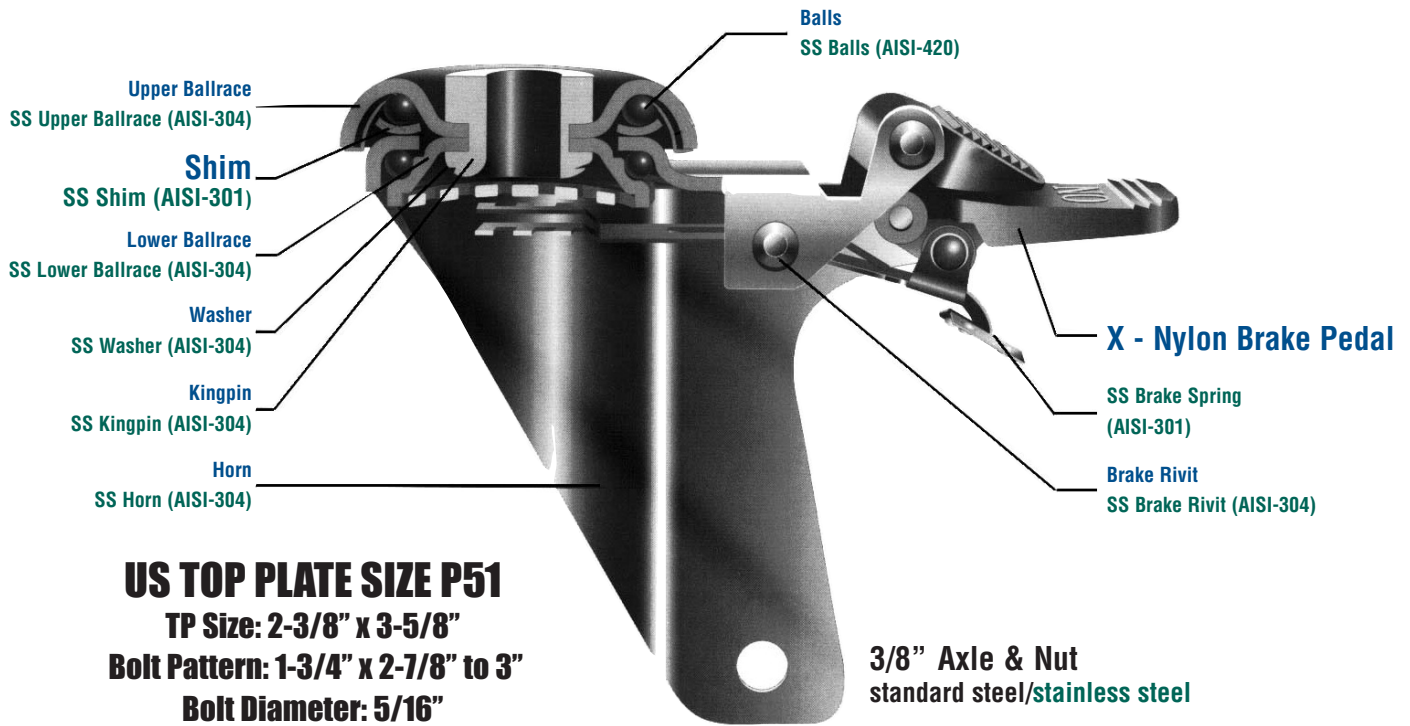

US TOP PLATE SIZE P51

TP Size: 2-3/8" x 3-5/8"

Bolt Pattern: 1-3/4" x 2-7/8" to 3"

Bolt Diameter: 5/16"

Swivel Caster



Swivel Caster
with Total Lock
& Plastic Pedal



Directional Lock
Plastic Petals



2C POLISHED CHROME FINISH PLATE CASTERS US TOP PLATE P51



**KR
WHEELS**

KRYPTONIC™ WHEELS

- Polyether Polyurethane has excellent carrying capacity.
- Crown shape affords an easy-rolling quiet operation.
- Greater service life and resistance to chunking, cutting and abrasive wear.

- 100% washable, steam cleanable, and resistant to most chemicals.
- Non-marking tread.
- Durometer: 58 Shore D (+/-5).
- Precision Ball Bearings.
- Temperature Range: +250°F for up to 2 hours.
- **Available in 5" gray +250°F for 5 to 6 hours.**

Part Number Swivel with Total Lock	Part Number Directional Lock	Part Number Swivel Caster	Wheel Diameter (inch)	Tread Width (inch)	Load Capacity (lbs)	Overall Height (mm)	Swivel Radius (mm)
2CKR3TLP51	2CKR3DLP51	2CKR3SP51	3	1-1/4	300	107	33
2CKR4TLP51	2CKR4DLP51	2KR4SP51	4	1-1/4	300	135	40.5
2CKR5TLP51	2CKR5DLP51	2CKR5SP51	5	1-1/4	300	161	39



**ANR
WHEELS**

ADVANCED RED RUBBER

- 80 (+5) Shore (A).
- Unique soft tread wheel handles the heat for autoclave applications.
- Roll quiet and smooth ride.

- Recommended for use in hospitals, laboratories and cleanrooms.
- Corrosion resistant thermoplastics.
- Resilient tread material rejects floor debris.
- Stainless Steel Precision Ball Bearings.
- Temp Range: -190°F to +300°F.

Part Number Swivel with Total Lock	Part Number Directional Lock	Part Number Swivel Caster	Wheel Diameter (inch)	Tread Width (inch)	Load Capacity (lbs)	Overall Height (mm)	Swivel Radius (mm)
2CANR4TLP51	2CANR4DLP51	2CANR4SP51	4	1-1/4	240	135	40.5
2CANR5TLP51	2CANR5DLP51	2CANR5SP51	5	1-1/4	240	161	39
2CANR6TLP51	2CANR6DLP51	2CANR6SP51	6	1-1/4	240	167	45



**RT
WHEELS**

RETORT

- 75 Durometer Shore (D).
- Designed to withstand the rigors of high temperature.

- Oversized bore ID ensures smooth movement.
- Moderate crown/White finish.
- Temp Range: -20°F to +290°F.

Part Number Swivel with Total Lock	Part Number Directional Lock	Part Number Swivel Caster	Wheel Diameter (inch)	Tread Width (inch)	Load Capacity (lbs)	Overall Height (mm)	Swivel Radius (mm)
2CRT3TLP51	2CRT3DLP51	2CRT3SP51	3	1-1/4	300	107	33
2CRT4TLP51	2CRT4DLP51	2CRT4SP51	4	1-1/4	300	135	40.5
2CRT5TLP51	2CRT5DLP51	2CRT5SP51	5	1-1/4	300	161	39

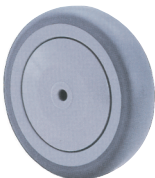

**TPR
WHEELS**

THERMOPLASTIC GRAY TREAD RUBBER PLASTIC HUB.

- 70 (+/-5) Durometer Shore (A).
- Recommended for clean environments.
- Resists most solvents, oil, grease, and water.

- Non-marking.
- Smooth rolling and quiet.
- Precision Ball Bearings.
- Temp Range: -45°F to +180°F.

Part Number Swivel with Total Lock	Part Number Directional Lock	Part Number Swivel Caster	Wheel Diameter (inch)	Tread Width (inch)	Load Capacity (lbs)	Overall Height (mm)	Swivel Radius (mm)
2CTPR3TLP51	2CTPR3DLP51	2CTPR3SP51	3	1-1/4	240	107	33
2CTPR4TLP51	2CTPR4DLP51	2CTPR4SP51	4	1-1/4	240	135	40.5
2CTPR5TLP51	2CTPR5DLP51	2CTPR5SP51	5	1-1/4	240	161	39

2C POLISHED CHROME FINISH PLATE CASTERS US TOP PLATE P51



PRB WHEELS

ELASTIC RUBBER

- Plastic hub material.
- Plastic 3" & Steel 4" & 5" thread guards.
- Gray color elastic rubber tire material.
- Precision Ball Bearings.
- Short-term temperature range: -40°/80°C.

Part Number Swivel with Total Lock	Part Number Directional Lock	Part Number Swivel Caster	Wheel Diameter (inch)	Tread Width (inch)	Load Capacity (lbs)	Overall Height (mm)	Swivel Radius (mm)
2CPRB3TLP51	2CPRB3DLP51	2CPRB3SP51	3	1-1/4	240	107	33
2CPRB4TLP51	2CPRB4DLP51	2CPRB4SP51	4	1-1/4	240	135	40.5
2CPRB5TLP51	2CPRB5DLP51	2CPRB5SP51	5	1-1/4	240	161	39



SRB WHEELS

ELASTIC RUBBER

- Pressed steel hub material.
- Steel thread guards.
- Gray color elastic rubber tire material.
- Precision Ball Bearings.
- Short-term temperature range: -40°/80°C.

Part Number Swivel with Total Lock	Part Number Directional Lock	Part Number Swivel Caster	Wheel Diameter (inch)	Tread Width (inch)	Load Capacity (lbs)	Overall Height (mm)	Swivel Radius (mm)
2CSRB4TLP51	2CSRB4DLP51	2CSRB4SP51	4	1-1/4	240	135	40.5
2CSRB5TLP51	2CSRB5DLP51	2CSRB5SP51	5	1-1/4	240	161	39
2CSRB6TLP51	2CSRB6DLP51	2CSRB6SP51	6	1-1/4	240	167	45



PM WHEELS

SOLID NYLON

- Steel thread guards.
- White color.
- Roller Bearings.
- Short-term temperature range: -30°/+120°C.

Part Number Swivel with Total Lock	Part Number Directional Lock	Part Number Swivel Caster	Wheel Diameter (inch)	Tread Width (inch)	Load Capacity (lbs)	Overall Height (mm)	Swivel Radius (mm)
2CPM3TLP51	2CPM3DLP51	2CPM3SP51	3	1-1/4	240	107	33
2CPM4TLP51	2CPM4DLP51	2CPM4SP51	4	1-1/4	240	135	40.5
2CPM5TLP51	2CPM5DLP51	2CPM5SP51	5	1-1/4	240	161	39



NAN WHEELS

NOISE ABSORBING NYLON

- Wheel: impact-resistant nylon
- 70° Shore (D)
- White with elastic solid rubber red damping ring.
- Precision Ball Bearing.

Part Number Swivel with Total Lock	Part Number Directional Lock	Part Number Swivel Caster	Wheel Diameter (inch)	Tread Width (inch)	Load Capacity (lbs)	Overall Height (mm)	Swivel Radius (mm)
2CNAN4TLP51	2CNAN4DLP51	2CNAN4SP51	4	1-1/4	400	135	40.5
2CNAN5TLP51	2CNAN5DLP51	2CNAN5SP51	5	1-1/4	400	161	39

2C POLISHED CHROME FINISH PLATE CASTERS US TOP PLATE P51



TPR/AS WHEELS

ANTI-STATIC PLASTIC HUB, GRAY COLOR CONDUCTIVE THERMOPLASTIC RUBBER TREAD

- 70 (+/-5) Durometer Shore (A).
- Anti-static plastic hub.

- Non-marking.
- Easy rolling, impact resistant and shock absorbing.
- Precision Ball Bearings.
- Temp Range: -40°F to +120°F.

Part Number Swivel with Total Lock	Part Number Directional Lock	Part Number Swivel Caster	Wheel Diameter (inch)	Tread Width (inch)	Load Capacity (lbs)	Overall Height (mm)	Swivel Radius (mm)
2CAS4TLP51	2CAS4DLP51	2CAS4SP51	4	1-1/4	240	135	40.5
2CAS5TLP51	2CAS5DLP51	2CAS5SP51	5	1-1/4	240	161	39
2CAS6TLP51	2CAS6DLP51	2CAS6SP51	6	1-1/4	240	167	45



TPU WHEELS

PLASTIC HUB, GRAY COLOR POLYURETANE TREAD

- 95 (+/-5) Durometer Shore (A).
- Plastic hub.

- Non-marking.
- High impact and abrasion resistant.
- Precision Ball Bearings.
- Temp Range: -40°F to +180°F.

Part Number Swivel with Total Lock	Part Number Directional Lock	Part Number Swivel Caster	Wheel Diameter (inch)	Tread Width (inch)	Load Capacity (lbs)	Overall Height (mm)	Swivel Radius (mm)
2CTPU3TLP51	2CTPU3DLP51	2CTPU3SP51	3	1-1/4	240	107	33
2CTPU4TLP51	2CTPU4DLP51	2CTPU4SP51	4	1-1/4	240	135	40.5
2CTPU5TLP51	2CTPU5DLP51	2CTPU5SP51	5	1-1/4	240	161	39

*steel tread guard

2C POLISHED CHROME FINISH PLATE CASTERS US TOP PLATE P51



**KR
WHEELS**

KRYPTONIC™ WHEELS

- Polyether Polyurethane has excellent carrying capacity.
- Crown shape affords an easy-rolling quiet operation.
- Greater service life and resistance to chunking, cutting and abrasive wear.

- 100% washable, steam cleanable, and resistant to most chemicals.
- Non-marking tread.
- Durometer: 58 Shore D (+/-5).
- Precision Ball Bearings.
- Temperature Range: +250°F for up to 2 hours.
- **Available in 5" gray +250°F for 5 to 6 hours.**

Part Number Swivel with Total Lock	Part Number Directional Lock	Part Number Swivel Caster	Wheel Diameter (inch)	Tread Width (inch)	Load Capacity (lbs)	Overall Height (mm)	Swivel Radius (mm)
2CSSKR3TLP51	2CSSKR3DLP51	2CSSKR3SP51	3	1-1/4	300	107	33
2CSSKR4TLP51	2CSSKR4DLP51	2CSSKR4SP51	4	1-1/4	300	135	40.5
2CSSKR5TLP51	2CSSKR5DLP51	2CSSKR5SP51	5	1-1/4	300	161	39



**ANR
WHEELS**

ADVANCED RED RUBBER

- 80 (+5) Shore (A).
- Unique soft tread wheel handles the heat for autoclave applications.
- Roll quiet and smooth ride.

- Recommended for use in hospitals, laboratories and cleanrooms.
- Corrosion resistant thermoplastics.
- Resilient tread material rejects floor debris.
- Stainless Steel Precision Ball Bearings.
- Temp Range: -190°F to +300°F.

Part Number Swivel with Total Lock	Part Number Directional Lock	Part Number Swivel Caster	Wheel Diameter (inch)	Tread Width (inch)	Load Capacity (lbs)	Overall Height (mm)	Swivel Radius (mm)
2CSSANR4TLP51	2CSSANR4DLP51	2CSSANR4SP51	4	1-1/4	240	135	40.5
2CSSANR5TLP51	2CSSANR5DLP51	2CSSANR5SP51	5	1-1/4	240	161	39
2CSSANR6TLP51	2CSSANR6DLP51	2CSSANR6SP51	6	1-1/4	240	167	45



**RT
WHEELS**

RETORT

- 75 Durometer Shore (D).
- Designed to withstand the rigors of high temperature.

- Oversized bore ID ensures smooth movement.
- Moderate crown/White finish.
- Temp Range: -20°F to +290°F.

Part Number Swivel with Total Lock	Part Number Directional Lock	Part Number Swivel Caster	Wheel Diameter (inch)	Tread Width (inch)	Load Capacity (lbs)	Overall Height (mm)	Swivel Radius (mm)
2CSSRT3TLP51	2CSSRT3DLP51	2CSSRT3SP51	3	1-1/4	300	107	33
2CSSRT4TLP51	2CSSRT4DLP51	2CSSRT4SP51	4	1-1/4	300	135	40.5
2CSSRT5TLP51	2CSSRT5DLP51	2CSSRT5SP51	5	1-1/4	300	161	39

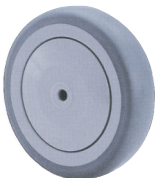

**TPR
WHEELS**

THERMOPLASTIC GRAY TREAD RUBBER PLASTIC HUB.

- 70 (+/-5) Durometer Shore (A).
- Recommended for clean environments.
- Resists most solvents, oil, grease, and water.

- Non-marking.
- Smooth rolling and quiet.
- Precision Ball Bearings.
- Temp Range: -45°F to +180°F.

Part Number Swivel with Total Lock	Part Number Directional Lock	Part Number Swivel Caster	Wheel Diameter (inch)	Tread Width (inch)	Load Capacity (lbs)	Overall Height (mm)	Swivel Radius (mm)
2CSSTPR3TLP51	2CSSTPR3DLP51	2CSSTPR3SP51	3	1-1/4	240	107	33
2CSSTPR4TLP51	2CSSTPR4DLP51	2CSSTPR4SP51	4	1-1/4	240	135	40.5
2CSSTPR5TLP51	2CSSTPR5DLP51	2CSSTPR5SP51	5	1-1/4	240	161	39

2 2E PLATE & STEM CASTERS

E PLATE FEATURES

Load Capacity Up to 350 lbs.

- Chrome plated
- Double Ball Bearing Raceway
- Heavy gauge cold rolled steel

CASTER OPTIONS

- 304 Stainless Steel - specify **SS** as prefix
- Dust Cover - specify **DC** or **DC SS** as suffix

OTHER OPTIONS

- Plastic grease seal on raceway **S** suffix
- High temp grease **T** suffix
- Zerk fitting on swivel raceway **F** suffix
- Zerk axle **Z** suffix



SERIES STEM TYPE*

Stem	Size	Stem Type
41	1/2-13 x 1	Threaded Stem
43	1/2-13 x 1-1/2	Threaded Stem
47	1/2-13 x 2-9/16	Threaded Stem
72	7/16 x 1-3/8	Grip Ring Stem
78	0.865 x 2-3/16	Grip Ring Stem
86	3/4 x 2	Octagon Stem
90	0.720 - 0.851	Expandable Adapter
91	0.852 - 0.927	Expandable Adapter
92	0.928 - 1.029	Expandable Adapter
93	1.030 - 1.140	Expandable Adapter
94	1.141 - 1.359	Expandable Adapter
95	1.360 - 1.425	Expandable Adapter
96	1.426 - 1.589	Expandable Adapter
97	1.790 - 1.850	Expandable Adapter

PLATES*

Plate	Size	Bolt Pattern	Bolt Dia.
01	2-3/8 x 3-5/8	1-3/4 x 2-7/8 to 3	5/16
02	3-1/8 x 4-1/8	1-3/4 x 2-15/16 to 2-3/8 x 3-3/8	5/16

TPR WHEELS

THERMOPLASTIC RUBBER TREAD ON POLYOLEFIN CORE.

- 70 (+/-5) Durometer Shore (A).
- Recommended for clean environments.
- Resists most solvents, oil, grease, and water.
- Non-marking.

- Smooth rolling and quiet.
- Precision Ball Bearings.
- Temp Range: -45°F to +180°F.

Options

- Donut Tread **DPR** replaces **TPR** in below chart



Part Number Swivel Caster	Part Number Swivel with Total Lock	Part Number Rigid Caster	Wheel Diameter (inch)	Tread Width (inch)	Load Capacity (lbs)	Overall Height (inch)	Swivel Radius (inch)
2ETPR3S	2ETPR3TL	2ETPR3R	3	1-1/4	210	4-3/16	3-3/16
2ETPR35S	2ETPR35TL	2ETPR35R	3-1/2	1-1/4	250	4-5/8	3-7/8
2ETPR4S	2ETPR4TL	2ETPR4R	4	1-1/4	300	7-1/2	4-9/16
2ETPR5S	2ETPR5TL	2ETPR5R	5	1-1/4	300	9-1/2	6-1/4

PPR WHEELS

HIGH TECH RUBBER FLAT TREAD

- Thermoplastic Elastomer Rubber mechanically bonded to polyolefin core.
- 65 (+/-5) Durometer Shore (A).
- Flat-spotting resistance under heavy loads.
- Temp Range: -45°F to + 180°F.

- Precision Ball Bearings.
- Non-marking.

Options

- Donut Tread **DTR** replaces **PPR** in below chart.



Part Number Swivel Caster	Part Number Swivel with Total Lock	Part Number Rigid Caster	Wheel Diameter (inch)	Tread Width (inch)	Load Capacity (lbs)	Overall Height (inch)	Swivel Radius (inch)
2EPPR3S	2EPPR3TL	2EPPR3R	3	1-1/4	300	4-3/16	2-21/32
2EPPR35S	2EPPR35TL	2EPPR35R	3-1/2	1-1/4	300	4-5/8	2-29/32
2EPPR4S	2EPPR4TL	2EPPR4R	4	1-1/4	325	5-1/8	3-13/16
2EPPR5S	2EPPR5TL	2EPPR5R	5	1-1/4	350	6-1/4	3-13/16

2 2E PLATE & STEM CASTERS

ERN WHEELS

ELASTIC RUBBER ON NYLON

- 70-75 Durometer Shore (A).
- Elastic rubber molded to nylon center.
- Non-marking.

- Easy rolling, impact resistant and shock absorbing.
- Precision Ball Bearings.
- Temp Range: -40°F to +160°F.



Part Number Swivel Caster	Part Number Swivel with Total Lock	Part Number Rigid Caster	Wheel Diameter (inch)	Tread Width (inch)	Load Capacity (lbs)	Overall Height (inch)	Swivel Radius (inch)
2EERN3S	2EERN3TL	2EERN3R	3	1-1/4	250	4-3/16	2-21/32
2EERN35S	2EERN35TL	2EERN35R	3-1/2	1-1/4	300	4-5/8	2-29/32
2EERN4S	2EERN4TL	2EERN4R	4	1-1/4	350	5-1/8	3-7/32
2EERN5S	2EERN5TL	2EERN5R	5	1-1/4	350	6-1/4	3-13/16

SPU WHEELS

SOLID POLYURETHANE

- 60 Durometer Shore (D).
- FDA requirements met for use in food processing environments.
- 100% Washable.

- One piece mold design eliminates bonding failure.
- High impact and abrasion resistant.
- Resists oil, grease, water, and most solvents.
- Precision Ball Bearings.
- Temp Range: -45°F to +180°F.



Part Number Swivel Caster	Part Number Swivel with Total Lock	Part Number Rigid Caster	Wheel Diameter (inch)	Tread Width (inch)	Load Capacity (lbs)	Overall Height (inch)	Swivel Radius (inch)
2ESPU3S	2ESPU3TL	2ESPU3R	3	1-1/4	300	4-3/16	2-21/32
2ESPU35S	2ESPU35TL	2ESPU35R	3-1/2	1-1/4	300	4-5/8	2-29/32
2ESPU4S	2ESPU4TL	2ESPU4R	4	1-1/4	325	5-1/8	3-7/32
2ESPU5S	2ESPU5TL	2ESPU5R	5	1-1/4	350	6-1/4	3-13/16

PTU WHEELS

POLYURETHANE ON POLYOLEFIN

- 90-95 Durometer Shore (A) Ductile Polyurethane tread mechanically bonded to Polyolefin core.
- High capacity and lightweight.
- Resists oil, grease, water, and most solvents.

- Smooth rolling and quiet.
 - Precision Ball Bearings.
 - Temp Range: -45°F to +180°F.
- Options**
- Donut Tread PTU (6", 8") DTU.



Part Number Swivel Caster	Part Number Swivel with Total Lock	Part Number Rigid Caster	Wheel Diameter (inch)	Tread Width (inch)	Load Capacity (lbs)	Overall Height (inch)	Swivel Radius (inch)
2EPTU3S	2EPTU3TL	2EPTU3R	3	1-1/4	250	4-3/16	2-21/32
2EPTU35S	2EPTU35TL	2EPTU35R	3-1/2	1-1/4	300	4-5/8	2-29/32
2EPTU4S	2EPTU4TL	2EPTU4R	4	1-1/4	325	5-1/8	3-7/32
2EPTU5S	2EPTU5TL	2EPTU5R	5	1-1/4	350	6-1/4	3-13/16

*Bearing types: Precision Ball Bearings or Stainless Steel

NOTE: All load ratings are for manual operation.

REPLACE 03 WITH APPROPRIATE STEM NUMBER OR PLATE NUMBER.

OTHER TYPE 1 1/4" WHEELS AVAILABLE FOR THIS SERIES:

NYLACRON™ MD (NY/MD), NYLACRON™ MONOCAST (NY/MC), HIGH TEMP WHEELS AVAILABLE. SEE WHEEL SECTION.

2 2J PLATE & STEM CASTERS

J FEATURES

Load Capacity Up to 325 lbs.

- Finish: bright zinc plating to resist rust and corrosion
- Design: heavy gauge cold rolled steel, formed for strength
- Dust Cap: all swivel models feature dust cap which protects swivel raceway bearings and improves performance
- Swivel Construction: double ball bearing with hardened raceways
- Axle: 3/8" diameter bolt with lock nut
- Kingpin: 1/2" steel rivet, hydraulically upset

CASTER OPTIONS

- PB/SS** Posi-loc brake - PB/SS - swivel only
VB/SS Vertilok brake - swivel only
GS/SSZ Grease Seals with zerks - swivel only

PLATE MOUNTING OPTIONS

- Top Plate Sizes (swivel & rigid): to order, add Plate Mounting Code to end of model number (Example: 5-30-105 PLT 1)

Mounting Code	Top Plate Size	Bolt Hole Spacing	Mounting Bolt Size
PLT 1	2-3/8 x 3-5/8	1-3/4 x 3	1/4
PLT 2	2-3/8 x 3-5/8	1-3/4 x 3	5/16
PLT 3	3-1/8 x 4-1/8	2-3/8 x 3-7/16	5/16



**2JGF5S
Swivel**

**2JHR5R
Rigid**

2 2J OPTIONS



**SERIES J
2JPG5SGS5
GRIP STEM**



**SERIES J
2JPW5STS5
THREADED STEM**



**SERIES J
2JHR5SES9
EXPANDED STEM**

J GRIP STEM MOUNTING OPTIONS

- J Grip Stem: to order, specify GS to the caster model number (Example: 2JPG5SGS1).

Stem Code	Round Stem Sizes
GS1	3/4" diameter x 2-3/16" long
GS2	13/16" diameter x 2-3/16" long
GS3	.845" diameter x 2-3/16" long
GS4	.865" diameter x 2-3/16" long
GS5	1" diameter x 2-3/16" long

Stem Code	Square Stem Sizes
GS6	.860" SQUARE x 2-3/16" long

J THREADED STEM MOUNTING OPTIONS

- J Threaded Stem Sizes: to order, specify stem code number and add to end of caster model number (Example: 2JPW5STS1).

Stem Code	Stem Sizes
TS1	1/2" dia. -13 x 3/4" long
TS2	1/2" dia. -13 x 1" long
TS3	1/2" dia. -13 x 1-1/2" long
TS4	1/2" dia. -20 x 3/4" long
TS5	1/2" dia. -20 x 2-1/4" long
TS6	5/8" dia. -11 x 1-1/4" long
TS7	5/8" dia. - 18 x 1-3/4" long
TS8	3/4" dia. - 10 x 1" long
TS9	3/4" Pipe Thread (1" actual stem diameter)
TS10	1" Pipe Thread (1-1/4" actual stem diameter)
TS11	1-1/4" Pipe Thread (1-1/2" actual stem diameter)

J EXPANDED STEM MOUNTING OPTIONS

- See chart below for adapter sizes and matching tube sizes. To order, add adapter number to end of model number (Example: 2JHR5SES9).
- Threaded stem size (less adapter): 1/2" diameter x 2- 3/4" long.

Adapter #	Tubing I.D.	Adapter #	Tubing I.D.
ES9	3/4"	ES17 B	1-3/16"
ES11	7/8"	ES19 C	1-3/8"
ES13	1"	ES19 A	1-1/2"
ES15	1-1/8"	ES21	1-7/8"

J OCTAGON STEM

Standard Octagon Stem Size: OC
3/4" octagon 2" long with 3 cross-drilled mounting holes.

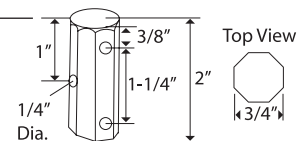

2 2J SWIVEL & TOP PLATE CASTERS

Diameter (inch)	Tread Width (inch)	Wheel Type	Bearing Type	Capacity (lbs.)	Weight Number*	Load Height (lbs.)	Swivel (inch)	Swivel Model Number*	Rigid model Radius
3	1-1/4	Cushion Rubber	Ball	150	1-3/4	4-1/8	3	2JCR3S	2JCR3R
3	1-1/4	Hard Rubber	Ball	220	1-3/4	4-1/8	3	2JHR3S	2JHR3R
3-1/2	1-1/4	Cushion Rubber	Ball	160	2	4-5/8	3-1/4	2JCR35S	2JCR35R
3-1/2	1-1/4	Welded Disc/Black Rubber	Ball	200	2-3/16	4-5/8	3-1/4	2JWDBR35S	2JWDBR35R
3-1/2	1-1/4	Welded Disc/Gray Rubber	Ball	225	2-3/16	4-5/8	3-1/4	2JWDGR35S	2JWDGR35R
3-1/2	1-1/4	Advantage TPR/Round	Ball	225	2-3/16	4-5/8	3-1/4	2JATPRR35S	2JATPRR35R
3-1/2	1-1/4	Advantage Heat Round	S.S. Ball	225	2-3/16	4-5/8	3-1/4	2JAHR35S	2JAHR35R
3-1/2	1-1/4	Advantage Heat Flat	S.S. Ball	225	2-3/16	4-5/8	3-1/4	2JAHF35S	2JAHF35R
3-1/2	1-1/4	Advantage Health	S.S. Ball	225	2-3/16	4-5/8	3-1/4	2JAH35S	2JAH35R
3-1/2	1-1/4	Hard Rubber	Ball	230	2-3/16	4-5/8	3-1/4	2JHR35S	2JHR35R
3-1/2	1-1/4	Welded Disc/Polyurethane	Ball	250	2-3/16	4-5/8	3-1/4	2JWDP35S	2JWDP35R
3-1/2	1-1/4	Advantage TPR/Flat	Flat Ball	250	2-3/16	4-5/8	3-1/4	2JATPRF35S	2JATPRF35R
3-1/2	1-1/4	PolyLoc/Gray	Ball	250	2-3/16	4-5/8	3-1/4	2JPG35S	2JPG35R
3-1/2	1-1/4	PolyLoc/Blue	Ball	250	2-3/16	4-5/8	3-1/4	2JPB35S	2JPB35R
4	1-1/4	Cushion Rubber	Ball	170	2-3/8	5-1/8	3-1/2	2JCR4S	2JCR4R
4	1-1/4	Welded Disc/Black Rubber	Ball	200	2-1/2	5-1/8	3-1/2	2JWDBR4S	2JWDBR4R
4	1-1/4	Welded Disc/Gray Rubber	Ball	200	2-1/2	5-1/8	3-1/2	2JWDGR4S	2JWDGR4R
4	1-1/4	Hard Rubber	Ball	250	2-3/8	5-1/8	3-1/2	2JHR4S	2JHR4R
4	1-1/4	Advantage TPR/Round	Ball	250	2-1/2	5-1/8	3-1/2	2JATPRR4S	2JATPRR4R
4	1-1/4	Welded Disc/Polyurethane	Ball	275	2-1/2	5-1/8	3-1/2	2JWDP4S	2JWDP4R
4	1-1/4	PolyLoc/Gray	Ball	275	2-1/2	5-1/8	3-1/2	2JPG4S	2JPG4R
4	1-1/4	PolyLoc/Blue	Ball	275	2-1/2	5-1/8	3-1/2	2JPB4S	2JPB4R
4	1-1/4	Advantage TPR/Flat	Ball	300	2-1/2	5-1/8	3-1/2	2JATPRF4S	2JATPRF4R
4	1-1/4	Advantage Heat/Round	S.S. Ball	300	2-1/2	5-1/8	3-1/2	2JAHR4S	2JAHR4R
4	1-1/4	Advantage Heat/Flat	S.S. Ball	300	2-1/2	5-1/8	3-1/2	2JAHF4S	2JAHF4R
4	1-1/4	Advantage Health	S.S. Ball	300	2-1/2	5-1/8	3-1/2	2JAH4S	2JAH4R
5	1-1/4	Cushion Rubber	Ball	200	2-3/4	6-1/4	4	2JCR5S	2JCR5R
5	1-1/4	Welded Disc/Black Rubber	Ball	200	3	6-1/4	4	2JWDBR5S	2JWDBR5R
5	1-1/4	Welded Disc/Gray Rubber	Ball	200	3	6-1/4	4	2JWDGR5S	2JWDGR5R
5	1-1/4	Advantage TPR/Round	Ball	250	3	6-1/4	4	2JATPRR5S	2JATPR5R
5	1-1/4	Hard Rubber	Ball	280	2-3/4	6-1/4	4	2JHR5S	2JHR5R
5	1-1/4	Welded Disc/Polyurethane	Ball	300	3	6-1/4	4	2JWDP5S	2JWDP5R
5	1-1/4	PolyLoc/Gray	Ball	300	3	6-1/4	4	2JPG5S	2JPG5R
5	1-1/4	PolyLoc/Blue	Ball	300	3	6-1/4	4	2JPB5S	2JPB5R
5	1-1/4	Polyolefin	Ball	300	3	6-1/4	4	2JPO5S	2JPO5R
5	1-1/4	Advantage Heat Round	S.S. Ball	300	3	6-1/4	4	2JAHR5S	2JAHR5R
5	1-1/4	Advantage Heat/Flat	S.S. Ball	300	3	6-1/4	4	2JAHF5S	2JAHF5R
5	1-1/4	Advantage Health	S.S. Ball	300	3	6-1/4	4	2JAH5S	2JAH5R
5	1-1/4	Advantage TPR/Flat	Ball	325	3	6-1/4	4	2JATPRF5S	2JATPRF5R
6	1-1/4	Welded Disc/Black Rubber	Ball	250	3-3/4	7-1/4	4-1/2	2JWDBR6S	2JWDBR6R
6	1-1/4	Welded Disc/Gray Rubber	Ball	250	3-3/4	7-1/4	4-1/2	2JWDGR6S	2JWDGR6R
6	1-1/4	Hard Rubber	Ball	300	3-1/8	7-1/4	4-1/2	2JHR6S	2JHR6R
6	1-1/4	Welded Disc/Polyurethane	Ball	300	3-3/4	7-1/4	4-1/2	2JWDP6S	2JWDP6R
6	1-1/4	Advantage TPR/Round	Ball	300	3-3/4	7-1/4	4-1/2	2JATPRR6S	2JATPR6R
6	1-1/4	PolyLoc/Gray	Ball	300	3-3/4	7-1/4	4-1/2	2JPG6S	2JPG6R
6	1-1/4	PolyLoc/Blue	Ball	300	3-3/4	7-1/4	4-1/2	2JPB6S	2JPB6R
6	1-1/4	Advantage Heat Round	S.S. Ball	325	3-3/4	7-1/4	4-1/2	2JAHR6S	2JAHR6R
6	1-1/4	Advantage Heat/Flat	S.S. Ball	325	3-3/4	7-1/4	4-1/2	2JAHF6S	2JAHF6R
6	1-1/4	Advantage Health	S.S. Ball	325	3-3/4	7-1/4	4-1/2	2JAH6S	2JAH6R

See Wheel Section for additional wheels to fit this series. Any type 1 1/4" wheel will fit this series.

J STAINLESS STEEL FEATURES

Load Capacity Up to 325 lbs.

- Finish: Polished stainless steel
- Dust Cap: all swivel models feature dust cap which protects swivel raceway bearings and improves performance
- Swivel Construction: stainless steel grade 440 ball bearings with hardened double raceway construction. Bearings are magnetic
- Axle: 3/8" diameter stainless steel axle with lock nut
- Kingpin: 1/2" stainless steel rivet, hydraulically upset
- Grease Temperature Range: -45°F to +260°F



2JSSPG5S
Swivel

2JSSPH5R
Rigid

CASTER OPTIONS ADD TO END OF MODEL NUMBER

- PL** Posi-loc brake - PB/SS - swivel only
- VL** Vertilok brake - swivel only
- GS** Grease Seals with zerks - swivel only
- TG** Tread Guards - see wheel section
- SL** Swivel Lock

PLATE MOUNTING OPTIONS

- Top Plate Sizes (swivel & rigid): to order, add Plate Mounting Code to end of model number (Example: 5-S30-314G PLT 2).

Mounting Code	Top Plate Size	Bolt Hole Spacing	Mounting Bolt Size
PLT 2	2-3/8" x 3-5/8"	1-3/4" x 3"	5/16"
PLT 3	3-1/8" x 4-1/8"	2-3/8" x 3-7/16"	5/16"

2 2JSS STAINLESS STEEL OPTIONS



2JSSPG5SGR1
Stainless Steel
Grip Stem



2JSSWDP5STS1
Stainless Steel
Threaded Stem



2JSSP05SES9
Stainless Steel
Expanded Stem

GRIP STEM MOUNTING OPTIONS

- **J STAINLESS STEEL** Grip Stem: to order, specify JSS & add to the caster model number (Example: 2JSSPG5SGR1).

Stem Code	Round Stem Sizes
GR1	3/4" diameter x 2-3/16" long
GR2	13/16" diameter x 2-3/16" long
GR3	.845" diameter x 2-3/16" long
GR4	.865" diameter x 2-3/16" long
GR5	1" diameter x 2-3/16" long

Stem Code	Square Stem Sizes
GR6	.860" SQUARE x 2-3/16" long

THREADED STEM MOUNTING OPTIONS

- **S36** Threaded Stem Sizes: to order, specify stem code number and add to end of caster model number (Example: 2JSSWDP5STS1).

Stem Code	Stem Sizes
TS1	1/2" dia. -13 x 3/4" long
TS2	1/2" dia. -13 x 1" long
TS3	1/2" dia. -13 x 1-1/2" long
TS4	1/2" dia. -20 x 3/4" long
TS5	1/2" dia. -20 x 2-1/4" long
TS6	5/8" dia. -11 x 1-1/4" long
TS7	5/8" dia. - 18 x 1-3/4" long
TS8	3/4" dia. - 10 x 1" long
TS9	3/4" Pipe Thread (1" actual stem diameter)
TS10	1" Pipe Thread (1-1/4" actual stem diameter)
TS11	1-1/4" Pipe Thread (1-1/2" actual stem diameter)

EXPANDED STEM MOUNTING OPTIONS

- See chart below for adapter sizes and matching tube sizes. To order, add adapter number to end of model number (Example: 2JSSP05SES9).
- Threaded stem size (less adapter): 1/2" diameter x 2- 3/4" long.

Adapter #	Tubing I.D.	Adapter #	Tubing I.D.
ES9	3/4"	ES17 B	1-3/16"
ES11	7/8"	ES19 C	1-3/8"
ES13	1"	ES19 A	1-1/2"
ES15	1-1/8"	ES21	1-7/8"

OCTAGON STEM

Standard Octagon Stem Size: OC

3/4" octagon 2" long with 3 cross-drilled mounting holes.

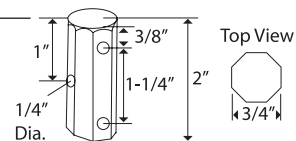

2

2JSS STAINLESS SWIVEL & RIGID CASTERS

Diameter (inch)	Tread Width	Wheel Type	Bearing Type	Capacity (lbs.)	Weight (lbs.)	Load Height	Swivel Radius	Swivel Model #	Rigid Model #
4	1-1/4	Polyolefin	SS Sleeve	300	2-1/4	5-1/16	3-1/2	2JSSP04S	2JSSP04R
4	1-1/4	Advantage Heat Flat ¹	SS Ball	300	2-1/4	5-1/16	3-1/2	2JSSAHF4S	2JSSAHF4R
4	1-1/4	Advantage Health	SS Ball	300	2-1/4	5-1/16	3-1/2	2JSSAH4S	2JSSAH4R
4	1-1/2	Phenolic	SS Sleeve	300	2-1/4	5-1/16	3-1/2	2JSSPH4S	2JSSPH4R
5	1-1/4	Advantage TPR/Round ²	SS Ball	250	2-3/4	6-1/8	4	2JSSATPRR5S	2JSSATPRR5R
5	1-1/4	Polyolefin	SS Sleeve	300	2-3/4	6-1/8	4	2JSSP05S	2JSSP05R
5	1-1/4	Welded Disc/polyurethane	SS Sleeve	300	2-3/4	6-1/8	4	2JSSWDP5S	2JSSWDP5R
5	1-1/4	PolyLoc/Gray ²	SS Ball	300	2-3/4	6-1/8	4	2JSSPG5S	2JSSPG5R
5	1-1/4	Advantage Heat Flat ¹	SS Ball	300	2-3/4	6-1/8	40	2JSSAHF5S	2JSSAHF5R
5	1-1/4	Advantage Health	SS Ball	300	2-3/4	6-1/8	4	2JSSAH5S	2JSSAH5R
5	1-1/2	Phenolic	SS Sleeve	300	2-3/4	6-1/8	4	2JSSPH5S	2JSSPH5R
6	1-1/4	Polyolefin	SS Sleeve	300	3-1/4	7-3/16	4-1/2	2JSSP06S	2JSSP06R
6	1-1/4	PolyLoc/Gray ¹	SS Ball	300	3-1/4	7-3/16	4-1/2	2JSSPG6S	2JSSPG6R
6	1-1/4	Advantage Heat Flat	SS Ball	325	3-1/4	7-3/16	4-1/2	2JSSAHF6S	2JSSAHF6R
6	1-1/4	Advantage Health	SS Ball	325	3-1/4	7-3/16	4-1/2	2JSSAH6S	2JSSAH6R
6	1-1/2	Phenolic	SS Sleeve	300	3-1/4	7-3/16	4-1/2	2JSSPH6S	2JSSPH6R

¹ Delrin bearing also available, consult factory.

² Advantage Heat round treads also available, change AHR.

2 2SA SHOCK ABSORBING CASTER

The cushion ride is a shock absorbing caster specifically designed for laboratory & office equipment which requires protection from shock and vibration. The unique design (Non-linear Deflection vs. Load) gives vertical wheel deflection in response to light load and will provide protection against heavier shock loads.

2SA SERIES FEATURES

- Computers or other laboratory or office equipment mounted on these casters will easily roll over floor irregularities such as carpet edges, thresholds, etc.
- If the unit is dropped or otherwise subjected to a sudden load, the caster will provide smooth shock absorption. The caster will not suddenly “hit bottom” or abruptly come to the limit of the caster spring system.
- Electronic equipment is characteristically designed to withstand a certain maximum, usually expressed in “g’s”.
- Cushion Ride II-3 can be modified so as to give the proper protection. Call us Toll Free for further information or quotation.

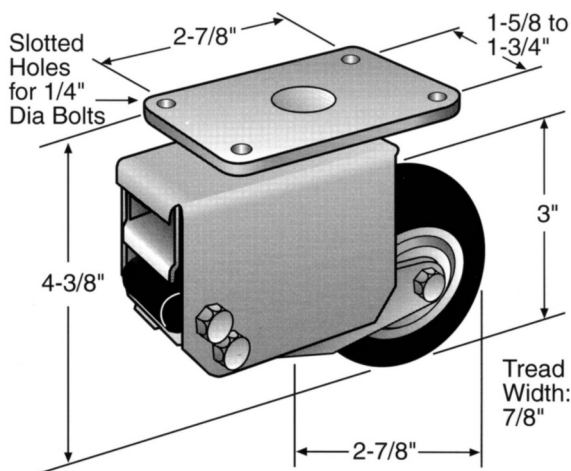

CUSHION RIDE II-3

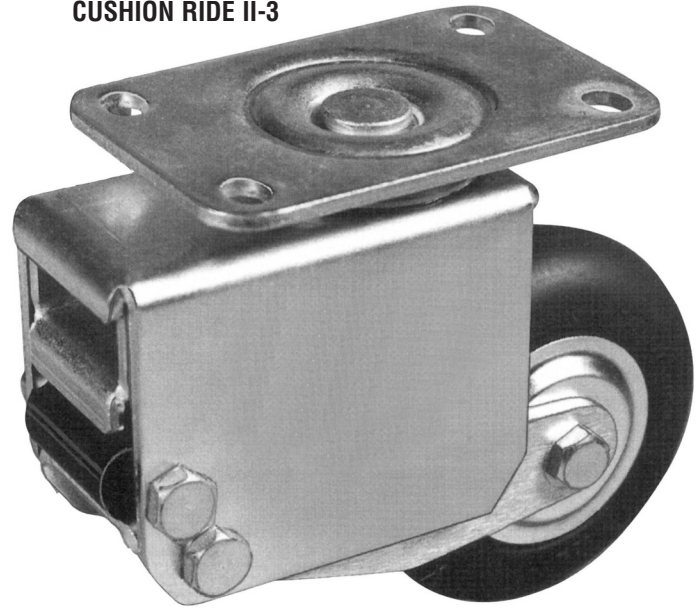

Neoprene Rubber Wheel

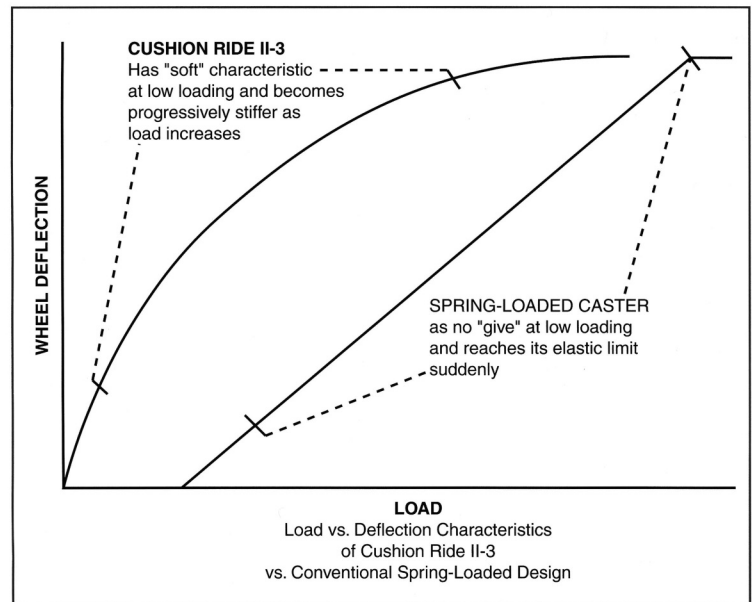

CASTER ORDERING #CR113XEZNRD

Also available with a variety of stems and top plates.
CAPACITY TO 110 LBS.