

4

40 SERIES HYBRID HEAVY DUTY KINGPIN CASTERS

3/4" Hardened kingpin bolt & nut

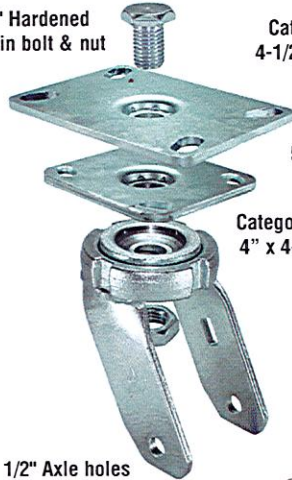

Category 5 Top Plate
4-1/2" x 6-1/4" (shown)
40-04

Also available in
5" x 5-1/2" (not shown)
40-05

Category 4 Top Plate
4" x 4-1/2" (shown)
40-03

1/2" Axle holes



HYBRID 8" SWIVEL CASTER



TOP LOCK
TS



CAM LOCK
MS



4 POSITION LOCK
PS



FOOT OPERATED SWIVEL LOCK
only available in
4" x 4-1/2" top plate

2,000 LBS. LOAD CAPACITY FORGED HYBRID KINGPIN CASTERS

- Kingpinless strength with Kingpin simplicity
- Kingpinless style drop forged swivel raceway
3/8" Ball bearings (HRC45 steel)
- 3/4" Kingpin/Nut hardened
- 1/4" Cold forged top plate (ASTM 1045)
- 1/2" Axle holes
- Long life of caster with low cost
- Extra high endurance in distance traveled
- Hub length 2 1/2"

**ALL WHEELS AVAILABLE
WITH PRECISION BEARINGS
OR ROLLER BEARINGS**

Caster Options: 304 Stainless Steel - "S" prefix

Other Options: Zerk axle - "Z" suffix

Plate size: 4" x 4 1/2"

Bolt Diameter: 3/8"

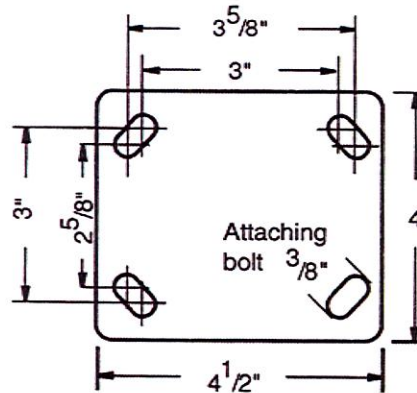

**STANDARD
46 03 TOP PLATE
4 X 4-1/2**

**BOLT HOLE CENTER
2-5/8 X 3-5/8
SLOTTED TO
3 X 3**

**ATTACHING BOLT SIZE
3/8**

4

40 SERIES HYBRID HEAVY DUTY KINGPIN CASTERS

MU
WHEELS

POLYURETHANE ON GLASS-FILLED NYLON

- 10mm blue tread
- 90-95 Durometer Shore (A) (Green Thread)
- 60-70 Durometer Shore (D)
- Light weight reinforced glass-filled nylon core

- Non-marking, non-staining, non-conductive tread
- Floor protective
- Resists oil, grease, water, and most solvents
- Temp Range: -45°F to +180°F



Part Number Swivel Caster	Part Number Rigid Caster	Wheel Diameter (inch)	Tread Width (inch)	Load Capacity (lbs)	Overall Height (inch)	Swivel Radius (inch)	Precision Bearing
40CS420MU63	40CR420MU63	4	2	800	5-5/8	3-1/8	63
40CS520MU63	40CR520MU63	5	2	1400	6-1/2	3-3/4	63
40CS620MU63	40CR620MU63	6	2	1400	7-1/2	4-1/2	63
40CS820MU63	40CR820MU63	8	2	1800	9-1/2	6-5/16	63

PTU
WHEELS

POLYURETHANE ON POLYOLEFIN

- 90-95 Durometer Shore (A) Ductile Polyurethane tread mechanically bonded to Polyolefin core
- High capacity and lightweight
- Resists oil, grease, water, and most solvents

- Smooth rolling and quiet
- Temp Range: -45°F to +180°F

Options

- Donut Tread PTU (6", 8") DTU



Part Number Swivel Caster	Part Number Rigid Caster	Wheel Diameter (inch)	Tread Width (inch)	Load Capacity (lbs)	Overall Height (inch)	Swivel Radius (inch)	Precision Bearing
40CS420PTU38	40CR420PTU38	4	2	700	5-5/8	3-1/8	38
40CS520PTU38	40CR520PTU38	5	2	1000	6-1/2	3-3/4	38
40CS620PTU38	40CR620PTU38	6	2	1200	7-1/2	4-1/2	38
40CS820PTU38	40CR820PTU38	8	2	1400	9-1/2	6-5/16	38

SEN
WHEELS

SOLID ELASTOMER WHEEL NYLON CORE

- 70 Shore (D) durometer
- FDA standards for use in food processing environments
- 100% Washable

- Glass-filled nylon core insert endures heat
- High impact and abrasion resistant
- Resists oil, grease, water, and most solvents
- Temp Range: -50°F to +180°F



Part Number Swivel Caster	Part Number Rigid Caster	Wheel Diameter (inch)	Tread Width (inch)	Load Capacity (lbs)	Overall Height (inch)	Swivel Radius (inch)	Precision Bearing
40CS420SEN63	40CR420SEN63	4	2	1500	5-5/8	3-1/8	63
40CS520SEN63	40CR520SEN63	5	2	1800	6-1/2	3-3/4	63
40CS620SEN63	40CR620SEN63	6	2	2100	7-1/2	4-1/2	63
40CS820SEN63	40CR820SEN63	8	2	2600	9-1/2	6-5/16	63

DS
WHEELS

DUCTILE STEEL

- Extreme heavy duty applications
- High capacity

- Effortless rolling under heavy loads
- Temp Range: -45°F to +800°F



Part Number Swivel Caster	Part Number Rigid Caster	Wheel Diameter (inch)	Tread Width (inch)	Load Capacity (lbs)	Overall Height (inch)	Swivel Radius (inch)	Precision Bearing
40CS420DS38	40CR420DS38	4	2	1200	5-5/8	3-1/8	38
40CS520DS38	40CR520DS38	5	2	1500	6-1/2	3-3/4	38
40CS620DS38	40CR620DS38	6	2	2000	7-1/2	4-1/2	38
40CS820DS38	40CR820DS38	8	2	2500	9-1/2	6-5/16	38

4

40 SERIES HYBRID HEAVY DUTY KINGPIN CASTERS

SPU
WHEELS

SOLID POLYURETHANE

- 60 Durometer Shore (D)
- FDA requirements met for use in food processing environments
- 100% Washable

- One piece mold design eliminates bonding failure
- High impact and abrasion resistant
- Resists oil, grease, water, and most solvents
- Temp Range: -45°F to +180°F



Part Number Swivel Caster	Part Number Rigid Caster	Wheel Diameter (inch)	Tread Width (inch)	Load Capacity (lbs)	Overall Height (inch)	Swivel Radius (inch)	Precision Bearing
40CS420SPU63	40CR420SPU63	4	2	700	5-5/8	3-1/8	63
40CS520SPU63	40CR520SPU63	5	2	1200	6-1/2	3-3/4	63
40CS620SPU63	40CR620SPU63	6	2	1200	7-1/2	4-1/2	63
40CS820SPU63	40CR820SPU63	8	2	1400	9-1/2	6-5/16	63

ERN
WHEELS

ELASTIC RUBBER ON NYLON

- 70-75 Durometer Shore (A)
- Elastic rubber molded to nylon core

- Non-marking
- Easy rolling, impact resistant and shock absorbing
- Temp Range: -40°F to +160°F



Part Number Swivel Caster	Part Number Rigid Caster	Wheel Diameter (inch)	Tread Width (inch)	Load Capacity (lbs)	Overall Height (inch)	Swivel Radius (inch)	Precision Bearing
40CS420ERN38	40CR420ERN38	4	2	325	5-5/8	3-1/8	38
40CS520ERN38	40CR520ERN38	5	2	475	6-1/2	3-3/4	38
40CS620ERN38	40CR620ERN38	6	2	500	7-1/2	4-1/2	38
40CS820ERN38	40CR820ERN38	8	2	600	9-1/2	6-5/16	38

NY/MD
WHEELS

NYLACRON™ WHEELS

- Precision Machined from Cast Polyamide. Hardness 112-120 Rockwell R
- Ultimate choice for Extremely High Load applications to replace metallic wheels
- Offer very high abrasion resistance and very low rolling resistance under extreme loads

- Resistant to salt, grease, alcohol and mild acids - can be used in corrosive applications with appropriate bearings
- Precision Ball Bearings
- Temperature Range: -40°F to +270°F

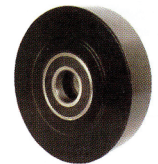

Part Number Swivel Caster	Part Number Rigid Caster	Wheel Diameter (inch)	Tread Width (inch)	Load Capacity (lbs)	Overall Height (inch)	Swivel Radius (inch)	Precision Bearing
40CS420NYMD	40CR420NYMD	4	2	2000	5-5/8	3-3/16	38
40CS520NYMD	40CR520NYMD	5	2	2000	6-1/2	3-7/8	38
40CS620NYMD	40CR620NYMD	6	2	2000	7-1/2	4-9/16	38
40CS820NYMD	40CR820NYMD	8	2	2000	9-1/2	6	38

4

40 SERIES HYBRID HEAVY DUTY KINGPIN CASTERS

TUA
WHEELS

POLYURETHANE ON ALUMINUM FLAT TREAD

- High Tech grade polyurethane tread
- 85 Durometer Shore (A) deflects debris
- Non-marking and rolls effortlessly
- Multi-year tread durability
- Temp Range: -40°F to +180°F

Part Number Swivel Caster	Part Number Rigid Caster	Wheel Diameter (inch)	Tread Width (inch)	Load Capacity (lbs)	Overall Height (inch)	Swivel Radius (inch)	Precision Bearing
40CS620TUA63	40CR620TUA63	6	2	1500	7-1/2	4-1/2	63
40CS820TUA63	40CR820TUA63	8	2	2000	9-1/2	6-5/16	63
40CS820TUA64	40CR820TUA64	8	2	2000	9-1/2	6-5/16	64

DUA
WHEELS

POLYURETHANE ON ALUMINUM DONUT TREAD

- High Tech grade polyurethane tread
- 85 Durometer Shore (A) deflects debris
- Non-marking and rolls effortlessly
- Multi-year tread durability
- Temp Range: -40°F to +180°F

Part Number Swivel Caster	Part Number Rigid Caster	Wheel Diameter (inch)	Tread Width (inch)	Load Capacity (lbs)	Overall Height (inch)	Swivel Radius (inch)	Precision Bearing
40CS420DUA63	40CR420DUA63	4	2	1000	5-5/8	3-1/8	63
40CS520DUA63	40CR520DUA63	5	2	1200	6-1/2	3-3/4	63
40CS620DUA63	40CR620DUA63	6	2	1500	7-1/2	4-1/2	63
40CS820DUA63	40CR820DUA63	8	2	2000	9-1/2	6-5/16	63

NG
WHEELS

NYLON GLASS-FILLED

- 85 Durometer Shore (A)
- Impervious to most chemicals, solvents, oil, salt, alkalines and water
- Use metal only bearing components for temperatures over 180°F
- Hi Temp: +490°F continuous, +550°F intermittent (part # TMA)

Part Number Swivel Caster	Part Number Rigid Caster	Wheel Diameter (inch)	Tread Width (inch)	Load Capacity (lbs)	Overall Height (inch)	Swivel Radius (inch)	Precision Bearing
40CS420NG38	40CR420NG38	4	2	800	5-5/8	3-1/8	38
40CS520NG38	40CR520NG38	5	2	1000	6-1/2	3-3/4	38
40CS620NG38	40CR620NG38	6	2	1200	7-1/2	4-1/2	38
40CS820NG38	40CR820NG38	8	2	1400	9-1/2	6-5/16	38

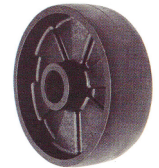
PPU
WHEELS

POLYURETHANE ON POLYOLEFIN

- Injection Molding Polyurethane Tread mechanically bonded to polyolefin core
- 90-95 Durometer Shore (A) Polyurethane Tread mechanically bonded to polyolefin core
- High capacity and lightweight
- Resist oil, grease, water and most solvents
- Smooth rolling and quiet
- Non-marking
- Temp Range: -45°F to +180°F

Part Number Swivel Caster	Part Number Rigid Caster	Wheel Diameter (inch)	Tread Width (inch)	Load Capacity (lbs)	Overall Height (inch)	Swivel Radius (inch)	Precision Bearing
40CS420PPU38	40CR420PPU38	4	2	700	5-5/8	3-1/8	38
40CS520PPU38	40CR520PPU38	5	2	750	6-1/2	3-3/4	38
40CS620PPU38	40CR620PPU38	6	2	900	7-1/2	4-1/2	38
40CS820PPU38	40CR820PPU38	8	2	1000	9-1/2	6-5/16	38

