

**FORGED STEEL/V-GROOVE**



**STEEL/STAINLESS STEEL**



**CAST IRON/V-GROOVE**

	<u>PAGE</u>
Forged Steel . . . . .	96-97
Ductile Iron . . . . .	98-99
Cast Iron . . . . .	100-103
Steel Wheels . . . . .	104-106
Stainless Steel . . . . .	107-108

## FORGED STEEL - FS

Capacity Up to 20,000 lbs.



Drop forged steel wheels are hot forged from carbon steel billets. The forging process improves grain flow, enhances ductility and tensile strength. Suitable for high capacity, abusive applications. Forged steel is 64,000 psi tensile strength.

### Features:

- **Wheel Face:** Flat with rounded edges.
- **Finish:** Clear coat enamel.
- **Temperature Range:** Up to 800°F.
- **Hardness:** Rockwell 80 B.

### Wheel Options

- **Note:** Select bearings featured are recommended for standard applications. For special applications or alternate bearings, consult Acorn™.
- For customization & special application options, please consult Acorn™.

## FORGED STEEL/ LARGE BORE - FH

Capacity Up to 20,000 lbs.

Dia. (inch)	Width (inch)	Capacity (lbs)	Hub Length (inch)	Bore (inch)	Bearing (inch)	Wt. (lbs)	Part Number*
6	2	1500	2-3/16	1-3/16	1/2	6-1/4	FS0620108
6	2	1500	2-3/16	1-3/16	5/8	6-1/4	FS0620110
6	2	1500	2-3/16	1-3/16	3/4	6-1/4	FS0620112
6	2	2500	2-7/16	1-3/8	1/2	6-1/4	FS0620908
6	2	2500	2-7/16	1-7/8	3/4	6-1/4	FS0620912
6	3	6000	3-1/4	2-7/16	1-1/4	20-1/4	FS0630120
6	3	6000	3-1/4	2-7/16	1-1/2	20-1/4	FS0630124
6	3	10,000	3-1/4	2-7/16	1	19-3/4	FS0630916
6	3	10,000	3-1/4	2-7/16	1-1/8	19-3/4	FS0630918
6	3	10,000	3-1/4	2-7/16	1-1/4	19-3/4	FS0630920
8	3	4500	3-1/4	1-15/16	1	18-1/4	FS0830116
8	3	4500	3-1/4	1-15/16	1-1/4	18-1/4	FS0830120
8	3	5500	3-1/2	1-15/16	3/4	18-1/4	FS0830912
8	3	5500	3-1/2	2-1/4	1	18-1/4	FS0830916
8	4	8350	4-1/4	2-7/16	1-1/4	35-1/2	FS0840120
8	4	8350	4-1/4	2-7/16	1-1/2	35-1/2	FS0840124
8	4	10,000	4-1/2	2-7/16	1	36-1/2	FS0840916
8	4	10,000	4-1/2	2-7/16	1-1/8	36-1/2	FS0840918
8	4	10,000	4-1/2	2-7/16	1-1/4	36-1/2	FS0840920
10	3	5000	3-1/4	1-15/16	1	27-3/4	FS1030116
10	3	5000	3-1/4	1-15/16	1-1/4	27-3/4	FS1030120
10	3	6000	3-1/2	1-15/16	3/4	27-1/2	FS1030912
10	4	8350	4-1/4	2-7/16	1-1/4	48	FS1040120
10	4	8350	4-1/4	2-7/16	1-1/2	48	FS1040124
10	4	10,000	4-1/2	2-7/16	1	47-1/4	FS1040916
10	4	10,000	4-1/2	2-7/16	1-1/8	47-1/4	FS1040918
10	4	10,000	4-1/2	2-7/16	1-1/4	47-1/4	FS1040920

\*R = Roller Bearing, P = Precision Ball Bearing, T = Tapered Roller Bearing

Dia. (inch)	Width (inch)	Capacity (lbs)	Hub Length (inch)	Bore (inch)	Bearing (inch)	Wt. (lbs)	Part Number*
6	3	17000	3-1/2	2-7/16	1-1/4	22-1/4	FH0650920
6	3	17000	3-1/2	2-7/16	1-1/2	22-1/4	FH0650924
8	3	6500	3-1/4	2-7/16	1-1/4	34	FH0850120
8	4	20000	4-1/2	3-1/8	1-1/4	34	FH0850920
8	4	20000	4-1/2	3-1/8	1-1/2	34	FH0850924
10	3	6000	3-1/4	2-7/16	1-1/4	37-1/4	FH01050120
10	3	6000	3-1/4	2-7/16	1-1/2	37-1/4	FH01050124
10	3	6500	3-1/2	2-7/16	1	37	FH01050916
10	3	6500	3-1/2	2.33	1-1/4	37	FH01050920
10	4	20000	4-1/2	3-1/8	1-1/4	46-1/4	FH01070920
10	4	20000	4-1/2	3-1/8	1-1/2	46-1/4	FH01070924

# FORGED STEEL/V-GROOVE

## FORGED STEEL/ V-GROOVE - VF/VH

Capacity Up to 20,000 lbs.

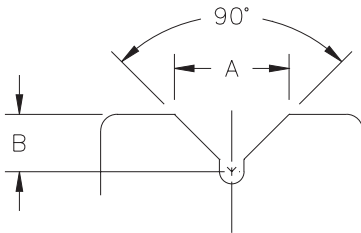

Wheel face and V-groove are machined from drop forged steel. A relief groove at the base of the “V” tends to equalize the load to each face of the angle track when in operation. Wheel face and bore are machined for concentricity to proper tracking. These wheels can be used not only on a track but flat surfaces as well. VH wheels feature a larger bore for greater capacity.

**Please note:** Track alignment is critical when utilizing V-groove wheels.

### Features

- **Wheel Face:** V-groove .
- **Finish:** Clear.

### Wheel Options

- **Note:** Select bearings featured are recommended for standard applications.
- For customization & special application options, consult Acorn™.

Wheel Dia. (inch)	Tread Width (inch)	Capacity (lbs)	Hub Length (inch)	Bore ID (inch)	Bearing ID (inch)	Groove Width “A”	Groove Depth “B”	Approx. Weight (lbs)	Part Number*
6	3	6000	3-1/4	2-7/16	1-1/4	1-3/8	11/16	20-1/4	VF0630120
6	3	6000	3-1/4	2-7/16	1-1/2	1-3/8	11/16	20-1/4	VF0630124
6	3	6500	3-1/2	2-7/16	1 1-3/8		11/16	19-3/4	VF0630916
6	3	6500	3-1/2	2-7/16	1-1/4	1-3/8	11/16	19-3/4	VF0630920
6	3	10000	3-1/2	3-1/8	1-1/4	1-3/8	11/16	22	VH0630920
6	3	10000	3-1/2	3-1/8	1-1/2	1-3/8	11/16	22	VH0630924
8	3	6000	3-1/4	1-15/16	1	7/8	7/16	30	VF0830116
8	4	8350	4-1/4	2-7/16	1-1/4	1-3/4	7/8	21-3/4	VF0840120
8	4	8350	4-1/4	2-7/16	1-1/2	1-3/4	7/8	21-3/4	VF0840124
8	4	10000	4-1/2	2-7/16	1	1-3/4	7/8	21	VF0840916
8	4	10000	4-1/2	2-7/16	1-1/4	1-3/4	7/8	21	VF0840920
8	4	15000	4-1/2	3-1/8	1-1/4	1-3/4	7/8	27-1/2	VH0840920
8	4	15000	4-1/2	3-1/8	1-1/2	1-3/4	7/8	27-1/2	VH0840924
10	3	6000	3-1/4	2-7/16	1-1/4	1-3/8	11/16	37-1/2	VH1030120
10	3	6000	3-1/4	2-7/16	1-1/2	1-3/8	11/16	37-1/2	VH1030124
10	3	6000	3-1/2	2-7/16	1	1-3/8	11/16	37	VH1030916
10	3	6000	3-1/2	2-7/16	1-1/4	1-3/8	11/16	37	VH1030920
10	3	5000	3-1/4	1-15/16	1	1-3/8	11/16	27-3/4	VF1030116
10	3	5000	3-1/4	1-15/16	1-1/4	1-3/8	11/16	27-3/4	VH1030120
10	4	8350	4-1/4	2-7/16	1-1/4	1-3/4	7/8	48	VH1040120
10	4	8350	4-1/4	2-7/16	1-1/2	1-3/4	7/8	48	VH1040124
10	4	10000	4-1/2	2-7/16	1	1-3/4	7/8	47-1/4	VH1040916
10	4	10000	4-1/2	2-7/16	1-1/4	1-3/4	7/8	47-1/4	VH1040920
10	4	15000	4-1/2	3-1/8	1-1/4	1-3/4	7/8	46-1/4	VH1040920
10	4	15000	4-1/2	3-1/8	1-1/2	1-3/4	7/8	46-1/4	VH1040924

\* R = Roller Bearing, P = Precision Ball Bearing, T = Tapered Roller Bearing

# DUCTILE IRON

## DUCTILE IRON/ FLAT TREAD - FM

Capacity Up to 6000 lbs.



### Features

- **Wheel Face:** FM flat tread design, FR full radius tread design.
- **Finish:** Black painted.

### • Temperature Range:

Up to +800°F.

### • Tensile Strength:

65K PSI.

Dia. (inch)	Width (inch)	Capacity (lbs)	Hub Length (inch)	Bore (inch)	Bearing (inch)	Wt. (lbs)	Part Number Plain Bore (00)	Part Number Roller Bearing (01)	Part Number Tapered Roller (09)
5	2	1500	2-3/16	1-3/16	3/4	6	FM0520019	FM0520112	
5	2	1500	2-3/16	1-3/16	1/2	6			FM0520908
6	2	1500	2-3/16	1-3/16	3/4	7-1/2	FM0620019	FM0620112	
6	2	2000	2-3/16	1-3/16	1/2	7-1/2			FM0620908
6	3	6000	3-1/4	1-15/16	1-1/4	11-1/2	FM0640013	FM0640120	
6	3	6000	3-1/4	1-15/16	1-1/4	11-1/2			FM0640912
8	2	2000	2-3/16	1-3/16	3/4	11	FM0820019	FM0820112	
8	2	2000	2-3/16	1-3/16	1/2	11			FM0820908
8	3	6000	3-1/4	1-15/16	1	15-1/2	FM08350031	FM0830116	
8	3	6000	3-1/4	1-15/16	3/4	15-1/2			FM0830912
10	3	6000	3-1/4	1-15/16	1-1/4	20-1/2	FM1030031	FM1030120	
10	3	6000	3-1/4	1-15/16	3/4	20-1/2			FM1030912

## DUCTILE IRON/ CROWN TREAD - FR

Capacity Up to 6000 lbs.



Dia. (inch)	Width (inch)	Capacity (lbs)	Hub Length (inch)	Bore (inch)	Bearing (inch)	Wt. (lbs)	Part Number Plain Bore (00)	Part Number Roller Bearing (01)	Part Number Tapered Roller (09)
5	2	1500	2-3/16	1-3/16	3/4	6	FR0520019	FR0520112	
5	2	1500	2-7/16	1-3/8	1/2	6			FR0520908
6	2	2000	2-3/16	1-3/16	3/4	7-1/2	FR0620019	FR0620112	
6	2	2000	2-7/16	1-3/8	1/2	7-1/2			FR0620908
6	3	6000	3-1/4	1-15/16	1-1/4	11-1/2	FR0630013	FR0630120	
6	3	6000	3-1/2	1-15/16	3/4	11-1/2			FR0630912
8	2	1500	2-3/16	1-3/16	1-3/16	11	FR0820019	FR0820112	
8	2	2000	2-7/16	1-3/8	1/2	11			FR0820908
8	3	5000	3-1/4	1-15/16	1-1/4	15-1/2	FR0830031	FR0830116	
8	3	6000	3-1/2	1-15/16	3/4	15-1/2			FR0830912
10	3	5000	3-1/4	1-15/16	1-1/4	20-1/2	FR1030031	FR1030120	
10	3	6000	3-1/2	1-15/16	3/4	20-1/2			FR1030912

## DUCTILE IRON/ V-GROOVE - VM

**Capacity Up to 6000 lbs.**



### V-Groove Measurements

- A: 6" & 8" wheel diameters = 7/8" wide  
10" wheel diameters = 1-3/8" wide
- B: 6" & 8" wheel diameters = 7/16" tall  
10" wheel diameters = 11/16" tall

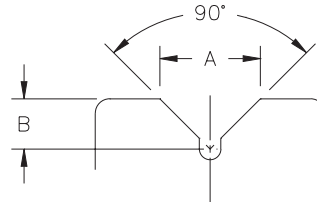

Wheel Dia. (inch)	Tread Width (inch)	Capacity (lbs)	Hub Length (inch)	Bore ID (inch)	Bearing ID (inch)	Groove Width "A"	Groove Depth "B"	Approx. Weight (lbs)	Part Number Roller Bearing (01)	Part Number Tapered Roller (09)
6	3	5000	3-1/4	1-15/16	1	7/8	7/16	10-1/2	VM0630116	
6	3	5000	3-1/4	1-15/16	1-1/4	7/8	7/16	10-1/2	VM0630120	
6	3	5000	3-1/2	1-15/16	3/4	7/8	7/16	10-1/2		VM0630912
8	3	5000	3-1/4	1-15/16	1	7/8	7/16	16-1/2	VM0830116	
8	3	5000	3-1/4	1-15/16	1-1/4	7/8	7/16	16-1/2	VM0830120	
8	3	5000	3-1/2	1-15/16	3/4	7/8	7/16	16-1/2		VM0830912
8	3	5000	3-1/2	1-15/16	1	7/8	7/16	16-1/2		VM0830916
10	3	6000	3-1/4	1-15/16	1	1-3/8	11/16	26	VM1030116	
10	3	6000	3-1/4	1-15/16	1-1/4	1-3/8	11/16	26	VM1030120	
10	3	6000	3-1/2	1-15/16	3/4	1-3/8	11/16	26		VM1030912
10	3	6000	3-1/2	1-15/16	1	1-3/8	11/16	26		VM1030916

\* R = Roller Bearing, P = Precision Ball Bearing, T= Tapered Roller Bearing

Available in STEEL or STAINLESS STEEL with precision ball bearings and end caps.

## CAST IRON - CA

Capacity Up to 8000 lbs.

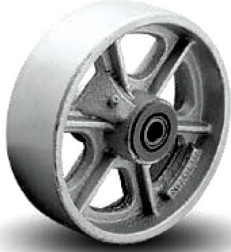

**Cast Iron**, sometimes referred to as semi-steel, offers the highest tensile strength in the industry (30,000 psi). A cost-effective solution for high capacity applications.

### Features:

- **Wheel face:** Machined flat with rounded edges.
- **Finish:** Gray enamel.
- **Temperature Range:** Up to 800°F, consult Acorn™.
- **Hardness:** Brinell 145.

### Wheel Options:

- **Note:** Select bearings featured are recommended for standard applications. For special applications or alternate bearings, consult Acorn™.
- For customization & special application options, please consult Acorn™.

Dia. (inch)	Width (inch)	Capacity (lbs)	Hub Length (inch)	Bore (inch)	Bearing (inch)	Wt. (lbs)	Part Number*
4	3	2000	3-1/4	1-15/16	1	8-1/4	CA0430116
4	3	2000	3-1/4	1-15/16	1-1/4	8-1/4	CA0430120
4	4	4000	4-1/4	2-7/16	1-1/4	10-3/4	CA0440120
4	4	4000	4-1/4	2-7/16	1-1/2	10-3/4	CA0440124
6	3	2800	3-1/4	1-15/16	1	11-3/4	CA0630116
6	3	2800	3-1/4	1-15/16	1 1/4	11-3/4	CA0630120
6	3	2800	3-1/2	1-15/16	3/4	11-1/2	CA0630912
8	2	1800	2-3/16	1-3/16	1/2	8-1/2	CA0820108
8	2	1800	2-3/16	1-3/16	5/8	8-1/2	CA0820110
8	2	1800	2-3/16	1-3/16	3/4	8-1/2	CA0820112
8	3	2800	3-1/4	1-15/16	1	11-3/4	CA0830116
8	3	2800	3-1/4	1-15/16	1-1/4	11-3/4	CA0830120
8	3	2800	3-1/2	1-15/16	3/4	11-1/2	CA0830912
8	4	4000	4-1/4	2-7/16	1-1/4	27-1/4	CA0840120
8	4	4000	4-1/4	2-7/16	1-1/2	27-1/4	CA0840124
8	4	6000	4-1/2	2-7/16	1	26-1/2	CA0840916
8	4	6000	4-1/2	2-7/16	1-1/4	26-1/2	CA0840920
10	3	2800	3-1/4	1-15/16	1	16-3/4	CA1030116
10	3	2800	3-1/4	1-15/16	1-1/4	16-3/4	CA1030120
10	3	2800	3-1/2	1-15/16	3/4	16-1/2	CA1030912
10	4	4000	4-1/4	2-7/16	1-1/4	33	CA1040120
10	4	4000	4-1/4	2-7/16	1-1/2	33	CA1040124
10	4	6000	4-1/2	2-7/16	1	32-1/2	CA1040916
10	4	6000	4-1/2	2-7/16	1-1/4	32-1/2	CA1040920
12	3	2800	3-1/4	1-15/16	1	22	CA1230116
12	3	2800	3-1/4	1-15/16	1-1/4	22	CA1230120
12	3	2800	3-1/2	1-15/16	3/4	21-3/4	CA1230912
14	4	4000	4-1/4	2-7/16	1-1/4	49-1/2	CA1440120
14	4	4000	4-1/4	2-7/16	1-1/2	49-1/2	CA1440124
16	3	4000	4-1/4	2-7/16	1-1/4	52-1/4	CA1630120
16	3	4000	4-1/4	2-7/16	1-1/2	52-1/4	CA1630124
16	4	5000	5-1/4	2-7/16	1-1/4	65-1/4	CA1640120
16	4	5000	5-1/4	2-7/16	1-1/2	65-1/4	CA1640124
18	3	4000	4-1/4	2-7/16	1-1/4	58	CA1830120
18	3	4000	4-1/4	2-7/16	2	58	CA1830124

## CAST IRON LARGE BORE CW



Dia. (inch)	Width (inch)	Capacity (lbs)	Hub Length (inch)	Bore (inch)	Bearing (inch)	Wt. (lbs)	Part Number*
<b>LARGE BORE PREMIUM CAST IRON (CA/LB) WITH HIGH TENSILE STRENGTH 30,000 PSI</b>							
8	3	6000	3-1/4	2-7/16	1-1/4	21-3/4	<b>CW0830120</b>
8	3	6000	3-1/4	2-7/16	1-1/2	21-3/4	<b>CW0830124</b>
8	3	8000	3-1/2	2-7/16	1	21-1/2	<b>CW0830916</b>
8	3	8000	3-1/2	2-7/16	1-1/4	21-1/2	<b>CW0830920</b>

\*R = Roller Bearing, P = Precision Ball Bearing, T = Tapered Roller Bearing

## CAST IRON HIGH TENSILE CH

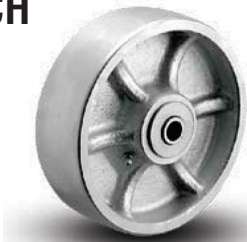

Dia. (inch)	Width (inch)	Capacity (lbs)	Hub Length (inch)	Bore (inch)	Bearing (inch)	Wt. (lbs)	Part Number Roller Bearing (01)	Part Number Bronze Bearing (22)*	Part Number Annular Ball Bearing (31)
<b>HEAVY DUTY PREMIUM CAST IRON (CA/HT) WITH HIGH TENSILE STRENGTH 30,000 PSI</b>									
5	2	1500	2-3/16	1-3/16	1/2	4-1/4	<b>CH0520108</b>		<b>CH0523108</b>
5	2	1500	2-3/16	1-3/16	5/8	4-1/4	<b>CH0520110</b>		
5	2	1500	2-3/16	1-3/16	3/4	4-1/4	<b>CH0520112</b>	<b>CH0522212</b>	
6	2	1700	2-3/16	1-3/16	1/2	6-1/4	<b>CH0620108</b>		<b>CH0623108</b>
6	2	1700	2-3/16	1-3/16	5/8	6-1/4	<b>CH0620110</b>		
6	2	1700	2-3/16	1-3/16	3/4	6-1/4	<b>CH0620112</b>	<b>CH0622212</b>	
8	2	1800	2-3/16	1-3/16	1/2	8-1/2	<b>CH0820108</b>		<b>CH0823108</b>
8	2	1800	2-3/16	1-3/16	5/8	8-1/2	<b>CH0820110</b>		
8	2	1800	2-3/16	1-3/16	3/4	8-1/2	<b>CH0820112</b>	<b>CH0822212</b>	

\*R = Roller Bearing, P = Precision Ball Bearing, T = Tapered Roller Bearing



## CAST IRON/ FLANGED - FL

Capacity Up to 8000 lbs.



Various bore sizes available for use as plain bore wheels or to be used with keyway and set screw, or with a variety of bearings. Cast iron offers 30,000 psi tensile strength.

### Features

- **Finish:** Gray enamel.
- **Temperature Range:** Up to 800°F, consult Acorn™.
- **Hardness:** Brinell 145.

### Wheel Options

- **Note:** Select bearings featured are recommended for standard applications. For special applications or alternate bearings, consult factory.
- For customization & special application options, please consult Acorn™.

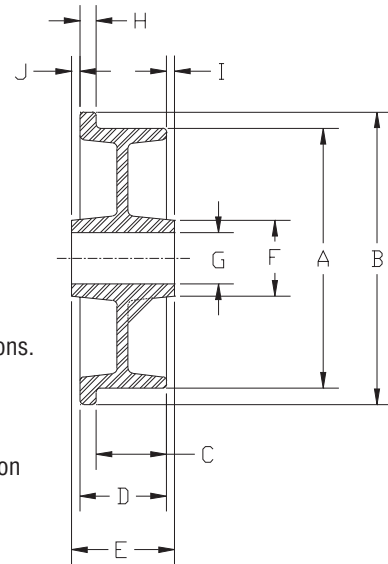

SINGLE FLANGED WHEELS (Dimensions in Inches)

Face Dia. "A"	Flange OD "B"	Face Width "C"	OA Width "D"	Hub Length "E"	Hub OD "F"	Bore "G"	Flange Width "H"	Hub Offset "I"	Hub Offset "J"	Capacity (lbs)	Bearing ID (inch)	Approx. Wt (lbs)	Part # R=Roller Brg T=Taper Brg
3	4	1	1-3/8	2-3/16	1-5/8	1-3/16	3/8	9/16	1/4	700	3/4	3	FL0320112
3-1/4	4	1	1-3/8	2-3/16	1-3/4	1-3/16	3/8	19/32	7/32	700	3/4	3	FL0310112
4-1/2	5-1/2	1-9/16	2-3/8	2-1/2	2-1/2	1-15/16	13/16	1/16	1/16	1500	1	9-1/2	FL0410116
4-1/2	5-1/2	1-9/16	2-3/8	2-1/2	2-1/2	1-15/16	13/16	1/16	1/16	1500	3/4	9-1/2	FL0410912
5	6	1-1/8	1-1/2	2-3/16	1-3/4	1-3/16	3/8	11/32	11/32	500	3/4	5-1/4	FL0510112
5-3/8	6-1/8	1-5/16	1-11/16	2-3/16	1-3/4	1-3/16	3/8	13/32	3/32	900	3/4	5	FL0520112
5	6	1-1/8	1-15/16	3-1/4	2-1/2	1-15/16	13/16	15/16	3/8	1000	1	6-1/2	FL0520116
5	6	1-1/8	1-15/16	3-1/4	2-1/2	1-15/16	13/16	15/16	3/8	1000	3/4	6-1/2	FL0520912
6	6-3/4	1-5/8	2	2-3/16	1-3/4	1-3/16	3/8	3/32	3/32	900	3/4	8-1/2	FL0620112
7-1/16	8-3/4	1-3/4	2-3/16	2-3/4	3-1/4	1-15/16	7/16	9/32	9/32	1200	1	12-3/4	FL0720116
7-1/16	8-3/4	1-3/4	2-3/16	2-3/4	3-1/4	1-15/16	7/16	9/32	9/32	1200	3/4	12-3/4	FL0720912
8	9-1/2	2	2-1/2	3-1/4	3	1-15/16	1/2	3/8	3/8	1600	1	16-1/4	FL0840116
8	9-1/2	2	2-1/2	3-1/4	3	1-15/16	1/2	3/8	3/8	1600	3/4	16-1/4	FL0840912
10	12	2-3/8	3	3-1/4	3	1-15/16	5/8	1/8	1/8	2000	1	29-1/4	FL1050116
10	12	2-3/8	3	3-1/4	3	1-15/16	5/8	1/8	1/8	2000	3/4	29-1/4	FL1050912
14	16	3	3-5/8	4-1/4	4-1/4	2-7/16	5/8	5/16	5/16	3000	1-1/4	56	FL1460120
14	16	3	3-5/8	4-1/4	4-1/4	2-7/16	5/8	5/16	5/16	3000	1	56	FL1460916

DOUBLE FLANGED WHEELS (Dimensions in Inches)

Face Dia. "A"	Flange OD "B"	Face Width "C"	OA Width "D"	Hub Length "E"	Hub OD "F"	Bore "G"	Flange Width "H"	Hub Offset "I"	Hub Offset "J"	Capacity (lbs)	Bearing ID (inch)	Approx. Wt (lbs)	Part # R=Roller Brg T=Taper Brg
5	6	3/4	1-1/2	2-3/16	1-3/4	1-3/16	3/8	11/32	11/32	500	3/4	6	FD0510112
10	12	1-3/4	3	3-1/4	3	1-15/16	5/8	1/8	1/8	2000	1	35	FD1050116
10	12	1-3/4	3	3-1/4	3	1-15/16	5/8	1/8	1/8	2000	3/4	35	FD1050912



## CAST IRON/ V-GROOVE - CA/VG

Capacity Up to 8000 lbs.

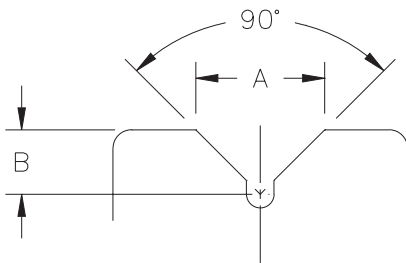

Wheel face and V-groove are machined from heavy duty cast iron. A relief groove at the base of the “V” tends to equalize the load to each face of the angle track when in operation. Wheel face and bore are machined for concentricity to proper tracking. These wheels can be used not only on track but flat surfaces as well. **CA/VL wheels feature a larger bore for greater capacity.**

**Please note:** Track alignment is critical when utilizing V-groove wheels.

### Wheel Options

- **Note:** Select bearings featured are recommended for standard applications. For special applications or alternate bearings, consult Acorn™.
- For customization & special application options, consult Acorn™.

Wheel Dia. (inch)	Tread Width (inch)	Capacity (lbs)	Hub Length (inch)	Bore ID (inch)	Bearing ID (inch)	Groove Width “A”	Groove Depth “B”	Approx. Weight (lbs)	Part # R= Roller Bearing
4	2	800	2-3/16	1-3/16	5/8	7/8	7/16	4	VG0420110
4	2	800	2-3/16	1-3/16	3/4	7/8	7/16	4	VG0420112
5	2	800	2-3/16	1-3/16	5/8	7/8	7/16	5	VG0520110
5	2	800	2-3/16	1-3/16	3/4	7/8	7/16	5	VG0520112
6	2	1000	2-3/16	1-3/16	5/8	7/8	7/16	8	VG0620110
6	2	1000	2-3/16	1-3/16	3/4	7/8	7/16	8	VG0620112
8	3	2500	3-1/4	1-15/16	1	7/8	7/16	16-3/4	VG0830116
8	3	2500	3-1/4	1-15/16	1-1/4	7/8	7/16	16-3/4	VG0830120
8	3	2500	3-1/2	1-15/16	3/4	7/8	7/16	16-1/2	VG0830920
8	3	2500	3-1/2	1.98	1	7/8	7/16	16-1/2	VG0830916
8	3	4000	3-1/4	2-7/16	1-1/4	1-3/8	11/16	17-3/4	VL0830120
8	3	4000	3-1/4	2-7/16	1-1/2	1-3/8	11/16	17-3/4	VL0830124
8	3	4000	3-1/2	2-7/16	1	1-3/8	11/16	17-1/4	VL0830916
8	3	4000	3-1/2	2-7/16	1-1/4	1-3/8	11/16	17-1/4	VL0830920
10	3	3000	3-1/4	1-15/16	1	1-3/8	11/16	27	VG1030116
10	3	3000	3-1/4	1-15/16	1-1/4	1-3/8	11/16	27	VG1030120
10	3	3500	3-1/2	1-15/16	3/4	1-3/8	11/16	26-3/4	VG1030912
10	3	3500	3-1/2	2	1	1-3/8	11/16	26-3/4	VG1030916
10	3	4000	3-1/4	2-7/16	1-1/4	1-3/8	11/16	28	VL1030120
10	3	4000	3-1/4	2-7/16	1-1/2	1-3/8	11/16	28	VL1030124
10	3	4000	3-1/2	2-7/16	1	1-3/8	11/16	27-1/4	VL1030916
10	3	4000	3-1/2	2-11/32	1-1/4	1-3/8	11/16	27-1/4	VL1030920

## STEEL - STL

Capacity Up to 20,000 lbs.



6" x 2" Steel Wheel  
with Precision Steel Ball Bearings  
and two Steel Bearing End Caps

Dia. (inch)	Width (inch)	Hub Length (inch)	Axle (inch)	Approx. Wt. (lb)	Capacity (lb)	Part Number P = Prec. Brg
4	1-1/2	1-5/8	1/2	7	600	STLP041508
4	2	2-3/8	1/2	10	1000	STLP042008
5	1-1/2	1-5/8	1/2	11	600	STLP051508
5	2	2-3/8	1/2	14	1000	STLP052008
6	1-1/2	1-5/8	1/2	15	600	STLP061508
6	2	2-3/8	1/2	20	1000	STLP062008
8	1-1/2	1-5/8	1/2	27	600	STLP081508
8	2	2-3/8	1/2	36	1000	STLP082008

P = Precision Ball bearing

Larger sizes available upon request.

### Features

- Type 1018 steel .
- Magnetic.
- Wheels can be machined straight sided or machined to contour.
- Slightly crowned tread face with rounded corners.
- Furnished with plain bore/steel bushing, stainless steel roller bearing or steel precision bearing .
- Steel wheels can be made to your specifications or drawings.

Steel Wheels provide the highest degree of sanitation. Type 1018 is magnetic. All wheels are available with Sealed Precision Ball Bearings, Bushings or Roller Bearings. Custom sizes made to prints to fit any application.

**ACORN™ MAKES END CAPS AND BUSHINGS TO FIT BEARING ID TO AXLE.**



**Custom Steel Wheels made by Acorn™ can be made in any size to fit any caster rig or wheel application and replace any type wheel.**

- V-Groove
- Flanged
- Crown Tread
- Rollers

## DROP FORGED STEEL - FS

**Capacity Up to 11000 lbs.**



### Features

- ASTM 1045 high carbon steel is hot drop forged to improve grain structure of the wheel, enhancing ductibility and tensile strength. This is the ultimate extreme duty wheel.
- Offers the maximum weight capacity, impact strength, durability and rollability of all our wheels.
- Tread face is precisely machined for a smooth, central ride, tread edge is machine round.
- Precision & tapered bearings maximize mobility and performance in towing and severe use environments.
- Hardness: Rockwell 80 B.
- Tensile strength of 60,000 PSI.
- Temperature up to +1300°F.

Diameter (inch)	Width (inch)	Hub Length	Capacity (lbs)	Roller Bearings	Tapered Bearings	Part Number
6	2	2-13/16	2500		73	FS62IT*
6	3	3-1/4	8000	27		FS63IT*
6	3	3-1/4	11000		70, 71, 79	FS63IT*
8	2	2-13/16	3000		73	FS82IT*
8	3	3-1/4	8000	27		FS83IT*
8	3	3-1/4	11000		70, 71, 79	FS83IT*
8	4	4-1/4	11000	33		FS84IT*
10	3	3-1/4	8000	27		FS1030IT*
10	3	3-1/4	11000		70, 71, 79	FS1030IT*
12	3	3-1/4	8000	27		FS1230IT*
12	3	3-1/4	11000		70, 71, 79	FS1230IT*
12	4	4-1/4	11000	33		FS1240IT*

Replace\* with desired bearing code.

**27, 33 Rolling Bearings**

**70, 71, 72, 79 Tapered Rolling Bearings w/top hat bushings**

## DUCTILE V-GROOVE - DV

Capacity Up to 7000 lbs.



### Features

- Made specifically for use on inverted angle iron track; they can also be used on flat surfaces.
- Each wheel has a precisely machined 90° V-groove with relief groove which enables load equalization.
- Ductile steel is a combination of special alloys that give it higher weight capacities than cast iron, and is more economical than drop forged steel; also referred to malleable iron; material may flex rather than cracking or breaking when submitted to an extreme shock load.
- Extra thick walled, heavy-duty core, hub & tread face.
- Precision & tapered bearings maximize mobility and performance in towing and severe use environments.
- Tensile strength of 45,000 PSI.
- Temperature -45°F up to +800°F.

Diameter (inch)	Width (inch)	Hub Length	Capacity (lbs)	Precision Ball Bearing*	Part Number
6	2	2-3/16	1500	63	DV60JT63
6	3	3-1/4	5000	65	DV60LT65
6	3	3-1/4	5000	65	DV60LW65
8	3	3-1/4	5000	65	DV80LT65
8	3	3-1/4	5000	65	DV80LW65
10	3	3-1/4	7000	65	DV10LT65
10	3	3-1/4	7000	65	DV10LW65

## SOLID STEEL V-GROOVE - SV

Capacity Up to 5000 lbs.



### Features

- Solid ASTM 1045 steel, straight sided construction offers the maximum weight capacity and durability of any V-groove type wheel on the market.
- Sealed precision ball bearings offer the best possible mobility and do not require any maintenance.
- Wheels are zinc plated to resist rust.
- Offers long service life; even in ongoing usage applications.
- Popular applications include use in casters and on sliding gates.
- Can be purchased as kits for gate use; includes bushings & axles.

Diameter (inch)	Width (inch)	Hub Length	Capacity (lbs)	Precision Bearing w/Bushing 1/2 ID	Precision Bearing w/Bushing 5/8 ID*	Part Number
4	2	1-13/16	3000	14	19	SV40IT14*
6	2	1-13/16	5000	14	19	SV60IT14*

# STAINLESS STEEL

## STAINLESS STEEL - SS

Capacity Up to 20,000 lbs.



6" x 2" Stainless Steel Wheel  
with Precision Stainless Steel Ball Bearings  
and two Stainless Steel Bearing End Caps

Dia. (in)	Width (in)	Hub Length (in)	Axle (in)	Approx. Wt. (lb)	Capacity (lb)	Part Number P = Prec. Brg
4	1-1/2	1-5/8	1/2	7	600	<b>SSP041508</b>
4	2	2-3/8	1/2	10	1000	<b>SSP042008</b>
5	1-1/2	1-5/8	1/2	11	600	<b>SSP051508</b>
5	2	2-3/8	1/2	14	1000	<b>SSP052008</b>
6	1-1/2	1-5/8	1/2	15	600	<b>SSP061508</b>
6	2	2-3/8	1/2	20	1000	<b>SSP062008</b>
8	1-1/2	1-5/8	1/2	27	600	<b>SSP081508</b>
8	2	2-3/8	1/2	36	1000	<b>SSP082008</b>

P = Precision Ball bearing

Larger sizes available upon request.

### Features

- Type 304 stainless steel.
- Non-magnetic.
- Non-sparking.
- Excellent corrosion resistance.
- Wheels can be machined straight sided or machined to contour.
- Excellent corrosion resistance.
- Slightly crowned tread face with rounded corners.
- Furnished with plain bore / stainless steel bushing, stainless steel roller bearing or stainless steel precision bearing.
- Stainless steel wheels can be made to your specifications or drawings.

**Custom Stainless Steel Wheels made by Acorn™ can be made in any size to fit any caster rig or wheel application and replace any type wheel.**

- V-Groove
- Flanged
- Crown Tread
- Rollers

Stainless Steel Wheels provide the highest degree of sanitation. Type 304 is a non-magnetic, non-sparking material with excellent corrosion resistance. All wheels are available with SS Sealed Precision Ball Bearings, SS Bushings or SS Roller Bearings. Custom sizes made to prints to fit any application.

**ACORN™ MAKES END CAPS AND BUSHINGS TO FIT BEARING ID TO AXLE.**

