

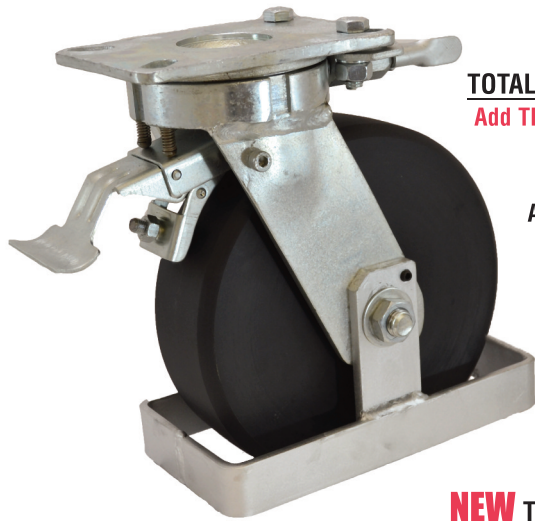

Caster Type	Page
4K Kingpinless Casters.....	2-4
4KSS Kingpinless Stainless Steel Casters.....	5-7
4KA Kingpinless Casters.....	8-11
4KAS Kingpinless Stainless Steel Casters.....	12-13
4H Hybrid Kingpin Casters.....	14-17
4D Kingpin Casters.....	18-25
4DSS Kingpin Stainless Steel Casters.....	26-29

**ALL WHEELS ARE AVAILABLE WITH
PRECISION BALL BEARING, CENTERPIECE & END CAPS
FOR MANUAL OR TOWING TO FIT IN 2-1/2" HUB LENGTH RIGS.
See Wheel Section for complete selection.**

4 4K KINGPINLESS CASTERS



**LEADING SIDE
TOTAL LOCK SWIVEL CASTER**
Add TL to swivel caster number

Available Toe Guard
TO

**NEW TRAILING SIDE
TOTAL LOCK SWIVEL CASTER**
No need to move cart back and forth
for finding the brake pedal.
Add TLN to swivel caster number



Swivel Head Section

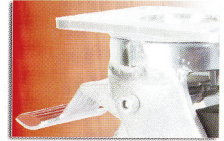

Total Lock System

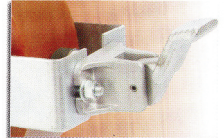

Wheel Face Brake



Directional Lock

2,000 LBS. LOAD CAPACITY FORGED KINGPINLESS TYPE CASTERS

- Single piece Drop Forged AISI 1045 Steel Top Plate and Fork Base.
- Precision CNC Machined Raceways with Kingpinless construction.
- Induction Hardening of Raceways ensures uniform depth of hardness.
- Totally Sealed Swivel Head with Grease Nipple.
- 1/4" Thick Fork Legs robotically welded inside & outside to 2 1/2" fork spacing.
- 1/2" Wheel axle.
- 4 Position Directional Lock Slots.
- Finish: Bright Zinc Plated.

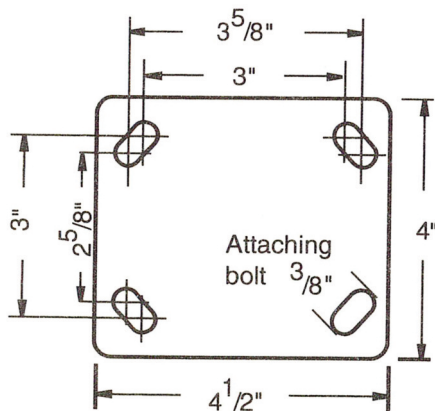

TOP PLATE
4 X 4-1/2

BOLT HOLE CENTER
2-5/8 X 3-5/8
SLOTTED TO
3 X 3

ATTACHING BOLT SIZE
3/8

TO: TOE GUARD
DL: DIRECTIONAL LOCK
WFB: WHEEL FACE BRAKE
ADD TO PART NUMBER

4 4K KINGPINLESS CASTERS

NY/MD WHEELS

NYLACRON™ CAST NYLON WHEELS

- Precision Machined from Cast Polyamide. Hardness 112-120 Rockwell R.
- Ultimate choice for extremely high load applications to replace metallic wheels.
- Offer very high abrasion resistance and very low rolling resistance under extreme loads.

- Resistant to salt, grease, alcohol and mild acids - can be used in corrosive applications with appropriate bearings.
- Precision Ball Bearings.
- Temperature Range: -40°F to +270°F.

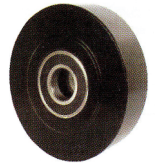

Part Number Swivel Caster	Part Number Swivel with Total Lock	Part Number Rigid Caster	Wheel Diameter (inch)	Tread Width (inch)	Load Capacity (lbs)	Overall Height (inch)	Swivel Radius (inch)	Swivel Radius w/Total Lock (inch)	Swivel Radius w/Wheel Brake (inch)
4KS42NYMD	4KTL42NYMD	4KR42MYMD	4	2	2000	5-5/8	3-3/16	4	8-1/2
4KS52NYMD	4KTL52NYMD	4KR52MYMD	5	2	2000	6-1/2	3-7/8	4	9-1/2
4KS62NYMD	4KTL62NYMD	4KR62MYMD	6	2	2000	7-1/2	4-9/16	6	10
4KS82NYMD	4KTL82NYMD	4KR82MYMD	8	2	2000	9-1/2	6	6	11-1/2

NY/MC WHEELS

NYLACRON™ MONOCAST CAST NYLON WHEELS

- Precision Machined from cast polyamide hardness 112-120 Rockwell R.
- Ultimate choice for extremely high load applications to replace metallic wheels.
- Offer very high abrasion resistance and very low rolling resistance under extreme loads.

- Resistant to salt, grease, alcohol and mild acids - can be used in corrosive applications with appropriate bearings.
- Precision Ball Bearings.
- Temperature Range: -40°F to +270°F.



Part Number Swivel Caster	Part Number Swivel with Total Lock	Part Number Rigid Caster	Wheel Diameter (inch)	Tread Width (inch)	Load Capacity (lbs)	Overall Height (inch)	Swivel Radius (inch)	Swivel Radius w/Total Lock (inch)	Swivel Radius w/Wheel Brake (inch)
4KS42NYMC	4KTL42NYMC	4KR42MYMC	4	2	2000	5-5/8	3-3/16	4	8-1/2
4KS52NYMC	4KTL52NYMC	4KR52MYMC	5	2	2000	6-1/2	3-7/8	4	9-1/2
4KS62NYMC	4KTL62NYMC	4KR62MYMC	6	2	2000	7-1/2	4-9/16	6	10
4KS82NYMC	4KTL82NYMC	4KR82MYMC	8	2	2000	9-1/2	6	6	11-1/2

Multi color Nylacron® Wheels available: (NY/MR) Red, (NY/MB) Blue & (NY/MO) Orange

4 4K KINGPINLESS CASTERS

SAS WHEELS

HIGH CAPACITY POLYURETHANE TREAD WHEELS CAST IRON CORE

- Polyurethane firmly bonded to Precision Machined Cast Iron Core.
- 93+ 3 Shore A.
- Low rolling resistance, smooth and noiseless running.

- Non-marking and floor protective.
- High abrasion, cut and tear resistant.
- Precision Ball Bearings.
- Temperature Range: -40°F to +180°F.



Part Number Swivel Caster	Part Number Swivel with Total Lock	Part Number Rigid Caster	Wheel Diameter (inch)	Tread Width (inch)	Load Capacity (lbs)	Overall Height (inch)	Swivel Radius (inch)	Swivel Radius w/Total Lock (inch)	Swivel Radius w/Wheel Brake (inch)
4KS42SAS	4KTL42SAS	4KR42SAS	4	2	900	5-5/8	3-3/16	4	8-1/2
4KS52SAS	4KTL52SAS	4KR52SAS	5	2	1200	6-1/2	3-7/8	4	9-1/2
4KS62SAS	4KTL62SAS	4KR62SAS	6	2	1650	7-1/2	4-9/16	6	10
4KS82SAS	4KTL82SAS	4KR82SAS	8	2	2000	9-1/2	6	6	11-1/2

ME WHEELS

ERGONOMIC POLYURETHANE DONUT TREAD WHEELS CAST IRON CORE

- For Low Push-Pull Efforts.
- Polyurethane firmly bonded to Precision Machined Cast Iron Core.
- 93+ 3 Shore A.
- Non-marking and floor protective.

- Tread Options: Softer 80A - Yellow Tread (specify ME-Z) and Harder 73D - Blue Tread (specify ME-F).
- Precision Ball Bearings.
- Temperature Range: -40°F to +180°F.



Part Number Swivel Caster	Part Number Swivel with Total Lock	Part Number Rigid Caster	Wheel Diameter (inch)	Tread Width (inch)	Load Capacity (lbs)	Overall Height (inch)	Swivel Radius (inch)	Swivel Radius w/Total Lock (inch)	Swivel Radius w/Wheel Brake (inch)
4KS42ME	4KTL42ME	4KR42ME	4	2	775	5-5/8	3-3/16	4	8-1/2
4KS52ME	4KTL52ME	4KR52ME	5	2	1000	6-1/2	3-7/8	4	9-1/2
4KS62ME	4KTL62ME	4KR62ME	6	2	1250	7-1/2	4-9/16	6	10
4KS82ME	4KTL82ME	4KR82ME	8	2	1700	9-1/2	6	6	11-1/2

SZS WHEELS

ELASTIC POLYURETHANE TREAD WHEELS CAST IRON CORE

- Polyurethane firmly bonded to Precision Machined Cast Iron Core.
- 85+ 3 Shore A.
- Excellent for power towing applications.

- Reduced noise due to cushioning of loads, Lively Polyurethane allows wheels to "Flex and Roll" over debris.
- Non-marking and floor protective.
- Precision Ball Bearings.
- Temperature Range: -40°F to +180°F.



Part Number Swivel Caster	Part Number Swivel with Total Lock	Part Number Rigid Caster	Wheel Diameter (inch)	Tread Width (inch)	Load Capacity (lbs)	Overall Height (inch)	Swivel Radius (inch)	Swivel Radius w/Total Lock (inch)	Swivel Radius w/Wheel Brake (inch)
4KS42SZS	4KTL42SZS	4KR42SZS	4	2	550	5-5/8	3-3/16	4	8-1/2
4KS52SZS	4KTL52SZS	4KR52SZS	5	2	775	6-1/2	3-7/8	4	9-1/2
4KS62SZS	4KTL62SZS	4KR62SZS	6	2	1000	7-1/2	4-9/16	6	10
4KS82SZS	4KTL82SZS	4KR82SZS	8	2	1450	9-1/2	6	6	11-1/2

4

4KSS KINGPINLESS STAINLESS STEEL CASTERS



**LEADING SIDE
TOTAL LOCK STAINLESS STEEL SWIVEL CASTER**

Add TL to swivel caster number

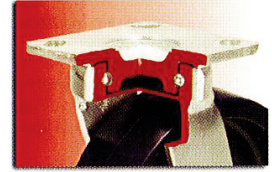

Swivel Head Section

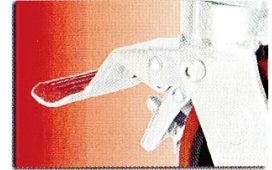

Total Lock System

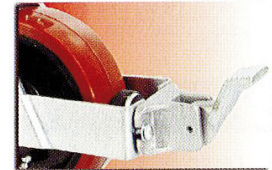

Wheel Face Break

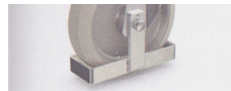

Specify Toe Guard
TO

2,000 LBS. LOAD CAPACITY STAINLESS STEEL KINGPINLESS TYPE CASTERS

- Fabricated AISI 304 Stainless Steel Top Plate and Fork Base.
- Precision CNC Machined Raceways with Kingpinless construction.
- Totally Sealed Swivel Head with Grease Nipple.
- 1/4" Thick Fork Legs Robotically welded Inside & Outside to 2 1/2" fork spacing.
- 1/2" Wheel axle.
- 4 Position Directional Lock Slots.
- Finish: Bright Zinc Plated.

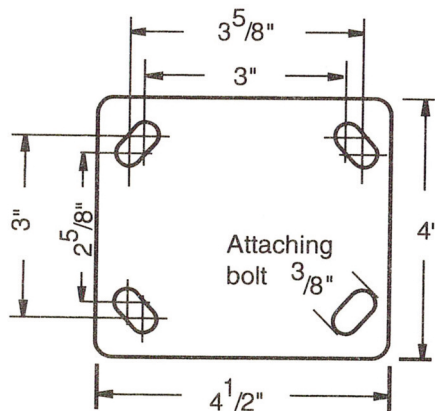

TOP PLATE
4 X 4-1/2

BOLT HOLE CENTER
2-5/8 X 3-5/8
SLOTTED TO
3 X 3

ATTACHING BOLT SIZE
3/8

TO: TOE GUARD
DL: DIRECTIONAL LOCK
WFB: WHEEL FACE BRAKE
ADD TO PART NUMBER

NY/MD
WHEELS

NYLACRON™ CAST NYLON WHEELS

- Precision Machined from Cast Polyamide. Hardness 112-120 Rockwell R.
- Ultimate choice for Extremely High Load applications to replace metallic wheels.
- Offer very high abrasion resistance and very low rolling resistance under extreme loads.

- Resistant to salt, grease, alcohol and mild acids - can be used in corrosive applications with appropriate bearings.
- Stainless Steel Precision Ball Bearings.
- Temperature Range: -40°F to +270°F.

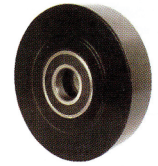

Part Number Swivel Caster	Part Number Swivel with Total Lock	Part Number Rigid Caster	Wheel Diameter (inch)	Tread Width (inch)	Load Capacity (lbs)	Overall Height (inch)	Swivel Radius (inch)	Swivel Radius w/Total Lock (inch)	Swivel Radius w/Wheel Brake (inch)
4KSS42NYMD	4KSSTL42NYMD	4KSSR42NYMD	4	2	2000	5-5/8	3-3/16	4	8-1/2
4KSS52NYMD	4KSSTL52NYMD	4KSSR52NYMD	5	2	2000	6-1/2	3-7/8	4	9-1/2
4KSS62NYMD	4KSSTL62NYMD	4KSSR62NYMD	6	2	2000	7-1/2	4-9/16	6	10
4KSS82NYMD	4KSSTL82NYMD	4KSSR82NYMD	8	2	2000	9-1/2	6	6	11-1/2

NY/MC
WHEELS

NYLACRON™ MONOCAST CAST NYLON WHEELS

- Precision Machined from Cast Polyamide Hardness 112-120 Rockwell R.
- Ultimate choice for Extremely High Load applications to replace metallic wheels.
- Offer very high abrasion resistance and very low rolling resistance under extreme loads.

- Resistant to salt, grease, alcohol and mild acids - can be used in corrosive applications with appropriate bearings.
- Stainless Steel Precision Ball Bearings.
- Temperature Range: -40°F to +270°F.



Part Number Swivel Caster	Part Number Swivel with Total Lock	Part Number Rigid Caster	Wheel Diameter (inch)	Tread Width (inch)	Load Capacity (lbs)	Overall Height (inch)	Swivel Radius (inch)	Swivel Radius w/Total Lock (inch)	Swivel Radius w/Wheel Brake (inch)
4KSS42NYMC	4KSSTL42NYMC	4KSSR42NYMC	4	2	2000	5-5/8	3-3/16	4	8-1/2
4KSS52NYMC	4KSSTL52NYMC	4KSSR52NYMC	5	2	2000	6-1/2	3-7/8	4	9-1/2
4KSS62NYMC	4KSSTL62NYMC	4KSSR62NYMC	6	2	2000	7-1/2	4-9/16	6	10
4KSS82NYMC	4KSSTL82NYMC	4KSSR82NYMC	8	2	2000	9-1/2	6	6	11-1/2

NN
WHEELS

NYLON WHEELS

- Injection molded from Nylon 6.
- 100% washable & steam cleanable; impervious to water, highly resistant to organic solvents, most chemicals & cleaning solutions; ideal for use in food processing and packaging plants.
- Offer high impact strength and exceptional abrasion resistance.

- Hard tread has slight crown and rolls very easily.
- Non-marking.
- Durometer: 75 Shore D (+/-5).
- Stainless Steel Precision Ball Bearings.
- Temperature Range: -40°F to +180°F.



Part Number Swivel Caster	Part Number Swivel with Total Lock	Part Number Rigid Caster	Wheel Diameter (inch)	Tread Width (inch)	Load Capacity (lbs)	Overall Height (inch)	Swivel Radius (inch)	Swivel Radius w/Total Lock (inch)	Swivel Radius w/Wheel Brake (inch)
4KSS82NN	4KSSTL82NN	4KSSR82NN	4	2	1320	5-5/8	3-3/16	4	8-1/2
4KSS52NN	4KSSTL52NN	4KSSR52NN	5	2	1320	6-1/2	3-7/8	4	9-1/2
4KSS62NN	4KSSTL62NN	4KSSR62NN	6	2	1320	7-1/2	4-9/16	6	10
4KSS82NN	4KSSTL82NN	4KSSR82NN	8	2	2000	9-1/2	6	6	11-1/2

4

4KSS KINGPINLESS STAINLESS STEEL CASTERS

SS
WHEELS

STAINLESS STEEL WHEELS

- Type 304 Stainless Steel.
- Non-magnetic & Non-sparking.
- Excellent corrosion resistance.
- Slightly crowned tread face with rounded corners.
- Stainless Steel Precision Ball Bearings.

- Temperature Range: 800°F.

**Custom Stainless Steel Wheels
made to your specifications.**

V-Groove - VG

Flanged - FL



Part Number Swivel Caster	Part Number Swivel with Total Lock	Part Number Rigid Caster	Wheel Diameter (inch)	Tread Width (inch)	Load Capacity (lbs)	Overall Height (inch)	Swivel Radius (inch)	Swivel Radius w/Total Lock (inch)	Swivel Radius w/Wheel Brake (inch)
4KSS42SS	4KSSTL42SS	4KSSR42SS	4	2	2000	5-5/8	3-3/16	4	8-1/2
4KSS52SS	4KSSTL52SS	4KSSR52SS	5	2	2000	6-1/2	3-7/8	4	9-1/2
4KSS62SS	4KSSTL62SS	4KSSR62SS	6	2	2000	7-1/2	4-9/16	6	10
4KSS82SS	4KSSTL82SS	4KSSR82SS	8	2	2000	9-1/2	6	6	11-1/2

SEN
WHEELS

SOLID ELASTOMER WHEEL NYLON CORE

- 70 Shore (D) durometer.
- FDA standards for use in food processing environments.
- 100% Washable.

- Stainless Steel Precision Ball Bearings.
- Glass-filled nylon core insert endures heat.
- High impact and abrasion resistant.
- Resists oil, grease, water, and most solvents.
- Temp Range: -50°F to +180°F.



Part Number Swivel Caster	Part Number Swivel with Total Lock	Part Number Rigid Caster	Wheel Diameter (inch)	Tread Width (inch)	Load Capacity (lbs)	Overall Height (inch)	Swivel Radius (inch)	Swivel Radius w/Total Lock (inch)	Swivel Radius w/Wheel Brake (inch)
4KSS42SEN	4KSSTL42SEN	4KSSR42SEN	4	2	1000	5-5/8	3-3/16	4	8-1/2
4KSS52SEN	4KSSTL52SEN	4KSSR52SEN	5	2	1400	6-1/2	3-7/8	4	9-1/2
4KSS62SEN	4KSSTL62SEN	4KSSR62SEN	6	2	1700	7-1/2	4-9/16	6	10
4KSS82SEN	4KSSTL82SEN	4KSSR82SEN	8	2	2000	9-1/2	6	6	11-1/2

KR
WHEELS

KRYTONIC™ WHEELS

- Polyether Polyurethane has excellent carrying capacity.
- Crown shape affords an easy-rolling quiet operation.
- Greater service life and resistance to chunking, cutting and abrasive wear.

- 100% washable, steam cleanable, and resistant to most chemicals.
- Non-marking tread.
- Durometer: 58 Shore D (+/-5).
- Stainless Steel Precision Ball Bearings.
- Temperature Range: + 250°F for up to 2 hours.



Part Number Swivel Caster	Part Number Swivel with Total Lock	Part Number Rigid Caster	Wheel Diameter (inch)	Tread Width (inch)	Load Capacity (lbs)	Overall Height (inch)	Swivel Radius (inch)	Swivel Radius w/Total Lock (inch)	Swivel Radius w/Wheel Brake (inch)
4KSS42KR	4KSSTL42KR	4KSSR42KR	4	2	500	5-5/8	3-3/16	4	8-1/2
4KSS52KR	4KSSTL52KR	4KSSR52KR	5	2	600	6-1/2	3-7/8	4	9-1/2
4KSS62KR	4KSSTL62KR	4KSSR62KR	6	2	700	7-1/2	4-9/16	6	10
4KSS82KR	4KSSTL82KR	4KSSR82KR	8	2	800	9-1/2	6	6	11-1/2

4 4KA KINGPINLESS CASTERS



**ALL WHEELS
AVAILABLE WITH
ROLLER BEARINGS
OR
DELTRIN BUSHING**

2,000 LBS. LOAD CAPACITY KINGPINLESS TYPE CASTERS

- **Top Plate:** 5/16" AISI 1045 steel welded and heat treated for longer life.
- **Yoke Base:** Notched AISI 1045 steel.
- **Swivel Section:** One row of 3/8" ball bearings mounted in a heat treated precision machined raceway. Zerk in swivel section.
- **Fork Legs:** 1/4" steel, formed to increase strength and welded on inside and outside yoke base. Fork lift spacing 2-1/2".
- **Axle:** 1/2" diameter hollow axle with zerk fitting on roller and tapered bearing models. (Solid axle on Delrin, precision ball, and Oilex models)
- **Finish:** Zinc plating.
- Alternate or custom caster configurations available.

Available with non-hardened raceways.

Suffix - NHR

Stamped Steel fully heat treated construction.

MOUNTING PLATE OPTIONS

TOP PLATE: (STANDARD)

Plate Size: 4" x 4-1/2"
Bolt Holes: 2-5/8" x 3-5/8"
 slotted to 3" x 3"
Bolt Size: 3/8"

TOP PLATE: K

Plate Size: 4-1/2" x 6-1/4"
Bolt Holes: 5-1/4" x 3-3/8"
 slotted to
 4-15/16" x 2-7/16"
Bolt Size: 1/2"

TOP PLATE: D

Plate Size: 5" x 5-1/2"
Bolt Holes: 4-1/8" x 4-1/2"
Bolt Size: 3/8"

TOP PLATE: J

Plate Size: 4" x 5"
Bolt Holes: 4" x 3"
 slotted to
 3-3/8" x 2-5/8"
Bolt Size: 5/8"

*Add options to end of part number

BRAKES OPTIONS

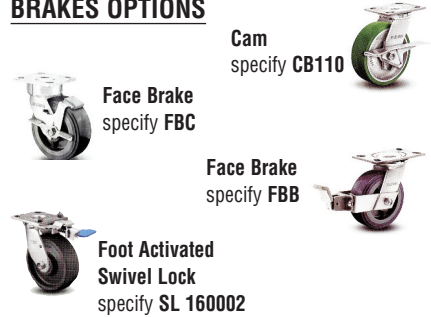

Cam
specify **CB110**

Face Brake
specify **FBC**

Face Brake
specify **FBB**

**Foot Activated
Swivel Lock**
specify **SL 160002**



**Specify Toe Guard
TO**

TYPICAL APPLICATIONS

- Dollies
- Dough troughs
- Platform trucks
- Tow line
- Utility carts
- Tooling fixtures
- Scrap metal carriers

BEARING OPTIONS

- Roller Bearing (01)
- Industrial Ball (27)
- Precision Ball (29)

4 4KA KINGPINLESS CASTERS

NY/MD WHEELS

NYLACRON™ CAST NYLON WHEELS

- Precision Machined from Cast Polyamide Hardness 112-120 Rockwell R.
- Ultimate choice for Extremely High Load applications to replace metallic wheels.
- Offer very high abrasion resistance and very low rolling resistance under extreme loads.

- Resistant to salt, grease, alcohol and mild acids - can be used in corrosive applications with appropriate bearings.
- Precision Ball Bearings.
- Temperature Range: -40°F to +270°F.

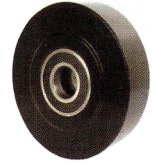

Part Number Swivel Caster	Part Number Rigid Caster	Wheel Diameter (inch)	Tread Width (inch)	Load Capacity (lbs)	Overall Height (inch)	Swivel Radius (inch)	Swivel Radius w/Total Lock (inch)	Swivel Radius w/Wheel Brake (inch)
4KAS42NYMD	4KAR42NYMD	4	2	2000	5-5/8	3-3/16	4	8-1/2
4KAS52NYMD	4KAR52NYMD	5	2	2000	6-1/2	3-7/8	4	9-1/2
4KAS62NYMD	4KAR62NYMD	6	2	2000	7-1/2	4-9/16	6	10
4KAS82NYMD	4KAR82NYMD	8	2	2000	9-1/2	6	6	11-1/2

NY/MC WHEELS

NYLACRON™ MONOCAST CAST NYLON WHEELS

- Precision Machined from Cast Polyamide. Hardness 112-120 Rockwell R.
- Ultimate choice for Extremely High Load applications to replace metallic wheels.
- Offer very high abrasion resistance and very low rolling resistance under extreme loads.

- Resistant to salt, grease, alcohol and mild acids - can be used in corrosive applications with appropriate bearings.
- Precision Ball Bearings.
- Temperature Range: -40°F to +270°F.



Part Number Swivel Caster	Part Number Rigid Caster	Wheel Diameter (inch)	Tread Width (inch)	Load Capacity (lbs)	Overall Height (inch)	Swivel Radius (inch)	Swivel Radius w/Total Lock (inch)	Swivel Radius w/Wheel Brake (inch)
4KAS42NYMC	4KAR42NYMC	4	2	2000	5-5/8	3-3/16	4	8-1/2
4KAS52NYMC	4KAR52NYMC	5	2	2000	6-1/2	3-7/8	4	9-1/2
4KAS62NYMC	4KAR62NYMC	6	2	2000	7-1/2	4-9/16	6	10
4KAS82NYMC	4KAR82NYMC	8	2	2000	9-1/2	6	6	11-1/2

Multi color Nylacron® Wheels available: (NY/MR) Red, (NY/MB) Blue & (NY/MO) Orange

4 4KA KINGPINLESS CASTERS

POLYURETHANE ON ALUMINUM ROUND TREAD PRECISION BALL BEARING PM9

- 90 - 95 Shore A durometer.
- Composed of a polyurethane elastomer open cast or injection molded, on clean, close tolerance cores.
- Wheels feature a chemical and mechanical lock of tread to the core.
- High capacity polyurethane protects floors.
- Non-marking.
- Delivers quieter operation than standard metal wheels.

Part Number Swivel Caster	Part Number Rigid Caster	Wheel Diameter (inch)	Tread Width (inch)	Load Capacity (lbs)	Overall Height (inch)	Swivel Lead (inch)	Approx. Weight (lbs)
4KAS52PM9	4KAR52PM9	5	2	1000	6-1/2	1-3/8	6
4KAS62PM9	4KAR62PM9	6	2	1250	7-1/2	1-9/16	7
4KAS82PM9	4KAR82PM9	8	2	1400	10-1/8	2-1/4	9



POLYURETHANE ON POLYPROPYLENE PRECISION BALL BEARING PM8

- Prevenz™ antimicrobial models available.
- Add PREV to end of caster number.
- Precision Ball 28 and annular ball 31 bearings available.
- Change “29” to other breaking code.

Part Number Swivel Caster	Part Number Rigid Caster	Wheel Diameter (inch)	Tread Width (inch)	Load Capacity (lbs)	Overall Height (inch)	Swivel Lead (inch)	Approx. Weight (lbs)
4KAS62PM8	4KAR62PM8	6	2	900	7-1/2	1-7/8	6-1/2
4KAS82PM8	4KAR82PM8	8	2	1000	9-1/2	2-3/8	8-1/2



ELASTIC BLUE RUBBER BALL BEARING ERB

- Elastic solid rubber, smooth rolling quality.
- Color Blue, 65° + 3° shore A.
- Vulcanized, for non-detachable bond, low rolling resistance.
- Precision Ball Bearings
- Made of aluminum die-cast, corrosion-resistant, with dual sealed precision ball bearings.

Part Number Swivel Caster	Part Number Rigid Caster	Wheel Diameter (inch)	Tread Width (inch)	Load Capacity (lbs)	Overall Height (inch)	Swivel Lead (inch)	Approx. Weight (lbs)
4KAS62ERB	4KAR62ERB	6	2	660	7-1/2	1-3/4	6-1/2
4KAS82ERB	4KAR82ERB	8	2	800	9-1/2	1-3/4	7-1/2



URETHANE ON BLACK NYLON PRECISION BALL BEARING XG

- Offers greater load capacity than rubber.
- Resists chemicals, acids, caustic, and oils.
- Precision Ball Bearings.
- Excellent for use in applications where ergonomic floor protective wheels are needed.

Part Number Swivel Caster	Part Number Rigid Caster	Wheel Diameter (inch)	Tread Width (inch)	Load Capacity (lbs)	Overall Height (inch)	Swivel Lead (inch)	Approx. Weight (lbs)
4KAS62XG	4KAR62XG	6	2	900	7-1/2	1-9/16	7-1/4
4KAS82XG	4KAR82XG	8	2	900	10-1/8	2-1/4	9

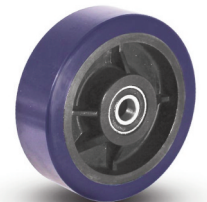

4

4KA KINGPINLESS CASTERS

SWE 80A CROWN TREAD WHEELS

FOR FLAT TREAD
SUFFIX FT

PREMIUM URETHANE WHEEL

- Reduces rolling resistance.
- Minimizes initial start forces.
- Prolongs the life of the swivel caster.
- Eliminates the need for costly dual-wheel caster.

- Carries 2x the load of standard size wheels with similar tread hardness.
- Maintenance-free for longer life.
- Non-marking, high-performance elastomer treads.
- Patented SWE® Precision Ball Bearing Design.
- Temp Range: -40°F to +180°F.

Part Number Swivel Caster	Part Number Rigid Caster	Wheel Diameter (inch)	Tread Width (inch)	Load Capacity (lbs)	Overall Height (inch)	Swivel Radius (inch)	Swivel Radius w/Wheel Brake (inch)
4KAS32SWE80ACRN	4KAR32SWE80ACRN	3	2	320	5-1/16	3-3/16	8-1/2
4KAS42SWE80ACRN	4KAR42SWE80ACRN	4	2	400	5-5/8	3-3/16	8-1/2
4KAS52SWE80ACRN	4KAR52SWE80ACRN	5	2	650	6-1/2	3-7/8	9-1/2
4KAS62SWE80ACRN	4KAR62SWE80ACRN	6	2	900	7-1/2	4-9/16	10
4KAS82SWE80ACRN	4KAR82SWE80ACRN	8	2	1400	9-1/2	6	11-1/2

SWE 95A CROWN TREAD WHEELS

FOR FLAT TREAD
SUFFIX FT

PREMIUM URETHANE WHEEL

- Reduces rolling resistance.
- Minimizes initial start forces.
- Prolongs the life of the swivel caster.
- Eliminates the need for costly dual-wheel caster.

- Carries 2x the load of standard size wheels with similar tread hardness.
- Maintenance-free for longer life.
- Non-marking, high-performance elastomer treads.
- Patented SWE® Precision Ball Bearing Design.
- Temp Range: -40°F to +180°F.

Part Number Swivel Caster	Part Number Rigid Caster	Wheel Diameter (inch)	Tread Width (inch)	Load Capacity (lbs)	Overall Height (inch)	Swivel Radius (inch)	Swivel Radius w/Wheel Brake (inch)
4KAS32SWE95ACRN	4KAR32SWE95ACRN	3	2	400	5-1/16	3-3/16	8-1/2
4KAS42SWE95ACRN	4KAR42SWE95ACRN	4	2	500	5-5/8	3-3/16	8-1/2
4KAS52SWE95ACRN	4KAR52SWE95ACRN	5	2	800	6-1/2	3-7/8	9-1/2
4KAS62SWE95ACRN	4KAR62SWE95ACRN	6	2	1100	7-1/2	4-9/16	10
4KAS82SWE95ACRN	4KAR82SWE95ACRN	8	2	1400	9-1/2	6	11-1/2

SWE 70D WHEELS

FOR FLAT TREAD
SUFFIX FT

PREMIUM URETHANE WHEEL

- Reduces rolling resistance.
- Minimizes initial start forces.
- Prolongs the life of the swivel caster.
- Eliminates the need for costly dual-wheel caster.

- Carries 2x the load of standard size wheels with similar tread hardness.
- Maintenance-free for longer life.
- Non-marking, high-performance elastomer treads.
- Patented SWE® Precision Ball Bearing Design.
- Temp Range: -40°F to +180°F.

Part Number Swivel Caster	Part Number Rigid Caster	Wheel Diameter (inch)	Tread Width (inch)	Load Capacity (lbs)	Overall Height (inch)	Swivel Radius (inch)	Swivel Radius w/Wheel Brake (inch)
4KAS32SWE70DCRN	4KAR32SWE70DCRN	3	2	520	5-1/16	3-3/16	8-1/2
4KAS42SWE70DCRN	4KAR42SWE70DCRN	4	2	800	5-5/8	3-3/16	8-1/2
4KAS52SWE70DCRN	4KAR52SWE70DCRN	5	2	1060	6-1/2	3-7/8	9-1/2
4KAS62SWE70DCRN	4KAR62SWE70DCRN	6	2	1300	7-1/2	4-9/16	10
4KAS82SWE70DCRN	4KAR82SWE70DCRN	8	2	1400	9-1/2	6	11-1/2

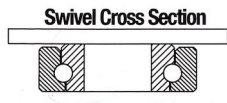

ALL WHEELS
AVAILABLE WITH
STAINLESS STEEL
ROLLER BEARINGS
OR
DELTRIN BUSHING

1,400 LBS. LOAD CAPACITY STAINLESS STEEL KINGPINLESS TYPE CASTERS

- **Top Plate:** 5/16" 304 stainless steel welded to 316 stainless raceway for longer life.
- **Yoke Base:** Notched 316 stainless steel welded inside and out.
- **Fork Legs:** 304 stainless steel welded inside and out. Fork lift spacing 2-1/2".
- **Swivel Section:** One row of 3/8" ball bearings mounted in a precision machined raceway. Zerk in swivel section.
- **Axle:** 1/2" diameter hollow axle with zerk fitting on roller and tapered bearing models. (Solid axle on Delrin, precision ball, and Oilflex models)
- Alternate or custom caster configurations available.

BRAKES OPTIONS



Face Brake
specify FBD

Cam
specify CB110



Foot Activated
Swivel Lock
specify SL 160002

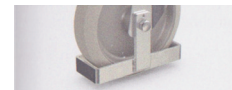

Specify Toe Guard
TO

Caster features premium grade 304 stainless steel caster rig with a strong premium 316 stainless swivel section. The caster is well suited for applications exposed to cleaning agents, steam, caustic solutions, or other corrosive agents which could cause rust.

TYPICAL APPLICATIONS

- Dollies
- Dough troughs
- Platform trucks
- Tow line
- Utility carts
- Tooling fixtures
- Scrap metal carriers

MOUNTING PLATE OPTIONS

TOP PLATE: (STANDARD)

Plate Size: 4" x 4-1/2"
Bolt Holes: 2-5/8" x 3-5/8"
slotted to 3" x 3"
Bolt Size: 3/8"

TOP PLATE: K

Plate Size: 4-1/2" x 6-1/4"
Bolt Holes: 5-1/4" x 3-3/8"
slotted to
4-15/16" x 2-7/16"
Bolt Size: 1/2"

TOP PLATE: D

Plate Size: 5" x 5-1/2"
Bolt Holes: 4-1/8" x 4-1/2"
Bolt Size: 3/8"

TOP PLATE: J

Plate Size: 4" x 5"
Bolt Holes: 4" x 3"
slotted to
3-3/8" x 2-5/8"

Bolt Size: 3/8"

*Add options to end of part number

BEARING OPTIONS

Roller Bearing (02)
Industrial Ball (27)
Precision Ball (29)

4

4KAS KINGPINLESS STAINLESS STEEL CASTERS

NY/MD WHEELS

NYLACRON™ CAST NYLON WHEELS

- Precision Machined from Cast Polyamide Hardness 112-120 Rockwell R.
- Ultimate choice for Extremely High Load applications to replace metallic wheels.
- Offer very high abrasion resistance and very low rolling resistance under extreme loads.

- Resistant to salt, grease, alcohol and mild acids - can be used in corrosive applications with appropriate bearings.
- Stainless Steel Precision Ball Bearings.
- Temperature Range: -40°F to +270°F.

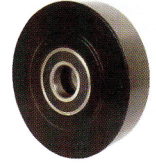

Part Number Swivel Caster	Part Number Rigid Caster	Wheel Diameter (inch)	Tread Width (inch)	Load Capacity (lbs)	Overall Height (inch)	Swivel Radius (inch)	Swivel Radius w/Total Lock (inch)	Swivel Radius w/Wheel Brake (inch)
4KASS42NYMD	4KASR42NYMD	4	2	1250	5-5/8	3-3/16	4	8-1/2
4KASS52NYMD	4KASR52NYMD	5	2	1250	6-1/2	3-7/8	4	9-1/2
4KASS62NYMD	4KASR62NYMD	6	2	1250	7-1/2	4-9/16	6	10
4KASS82NYMD	4KASR82NYMD	8	2	1250	9-1/2	6	6	11-1/2

NY/MC WHEELS

NYLACRON™ NYLON MONOCAST CAST WHEELS

- Precision Machined from Cast Polyamide Hardness 112-120 Rockwell R.
- Ultimate choice for Extremely High Load applications to replace metallic wheels.
- Offer very high abrasion resistance and very low rolling resistance under extreme loads.

- Resistant to salt, grease, alcohol and mild acids - can be used in corrosive applications with appropriate bearings.
- Stainless Steel Precision Ball Bearings.
- Temperature Range: -40°F to +270°F.



Part Number Swivel Caster	Part Number Rigid Caster	Wheel Diameter (inch)	Tread Width (inch)	Load Capacity (lbs)	Overall Height (inch)	Swivel Radius (inch)	Swivel Radius w/Total Lock (inch)	Swivel Radius w/Wheel Brake (inch)
4KASS42NYMC	4KASR42NYMC	4	2	1250	5-5/8	3-3/16	4	8-1/2
4KASS52NYMC	4KASR52NYMC	5	2	1250	6-1/2	3-7/8	4	9-1/2
4KASS62NYMC	4KASR62NYMC	6	2	1250	7-1/2	4-9/16	6	10
4KASS82NYMC	4KASR82NYMC	8	2	1250	9-1/2	6	6	11-1/2

KR WHEELS

KRYPTONIC™ WHEELS

- Polyether Polyurethane has excellent carrying capacity.
- Crown shape affords an easy-rolling, quiet operation.
- Greater service life and resistance to chunking, cutting and abrasive wear.

- 100% washable, steam cleanable, and resistant to most chemicals.
- Non-marking tread.
- Durometer: 58 Shore D (+/-5).
- Stainless Steel Precision Ball Bearings.
- Temperature Range: + 250°F for up to 2 hours.



Part Number Swivel Caster	Part Number Rigid Caster	Wheel Diameter (inch)	Tread Width (inch)	Load Capacity (lbs)	Overall Height (inch)	Swivel Radius (inch)	Swivel Radius w/Total Lock (inch)	Swivel Radius w/Wheel Brake (inch)
4KASS42KR	4KASR42KR	4	2	800	5-5/8	3-3/16	4	8-1/2
4KASS52KR	4KASR52KR	5	2	900	6-1/2	3-7/8	4	9-1/2
4KASS62KR	4KASR62KR	6	2	900	7-1/2	4-9/16	6	10
4KASS72KR	4KASR72KR	8	2	900	9-1/2	6	6	11-1/2

OTHER TYPE WHEELS AVAILABLE FOR THIS SERIES:
SEE WHEEL SECTION FOR COMPLETE SPECIFICATIONS.

4 4H HYBRID KINGPIN CASTERS

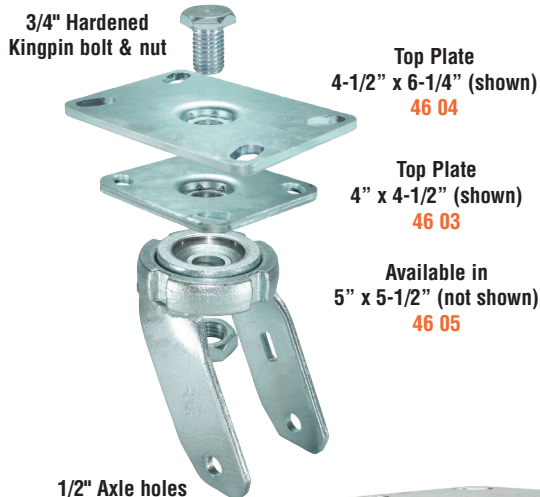

Top Plate
4-1/2" x 6-1/4" (shown)
46 04

Top Plate
4" x 4-1/2" (shown)
46 03

Available in
5" x 5-1/2" (not shown)
46 05

1/2" Axle holes

NOW AVAILABLE IN STAINLESS STEEL
& CUSTOM STEMS
CONSULT ACORN FOR MORE DETAILS



HYBRID 8" SWIVEL CASTER
WITH NYLACRON™ WHEEL



TOP LOCK
TS



CAM LOCK
MS



4 POSITION
LOCK
PS

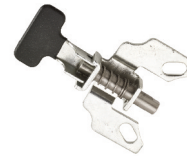

FOOT OPERATED
SWIVEL LOCK
only available in
4" x 4-1/2" top plate
DL

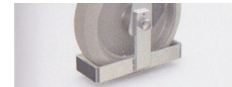

Specify Toe Guard
TO

2,000 LBS. LOAD CAPACITY FORGED HYBRID KINGPIN CASTERS

- Kingpinless strength with Kingpin simplicity.
- Kingpinless style drop forged swivel raceway 3/8" Ball bearings (HRC45 steel).
- 3/4" Kingpin/Nut hardened.
- 1/4" Cold forged top plate (ASTM 1045).
- 1/2" Axle holes.
- Long life of caster with low cost.
- Extra high endurance in distance traveled .
- Hub length 2 1/2".

ALL WHEELS
AVAILABLE WITH
ROLLER BEARINGS
OR
DELRIN BUSHING

Caster Options: 304 Stainless Steel - "S" prefix
Other Options: Zerk axle - "Z" suffix
Plate size: 4" x 4 1/2"
Bolt Diameter: 3/8"

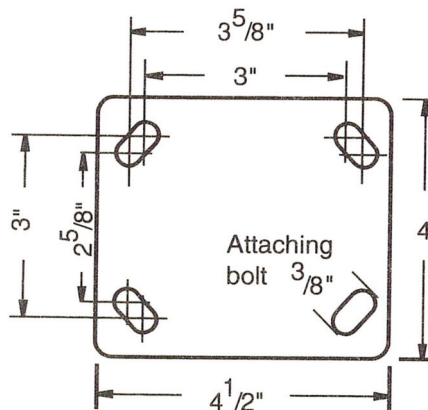

STANDARD
46 03 TOP PLATE
4 X 4-1/2

BOLT HOLE CENTER
2-5/8 X 3-5/8
SLOTTED TO
3 X 3

ATTACHING BOLT SIZE
3/8

4

4H HYBRID KINGPIN CASTERS

NY/MD WHEELS

NYLACRON™ CAST NYLON WHEELS

- Precision Machined from Cast Polyamide Hardness 112-120 Rockwell R.
- Ultimate choice for Extremely High Load applications to replace metallic wheels.
- Offer very high abrasion resistance and very low rolling resistance under extreme loads.

- Resistant to salt, grease, alcohol and mild acids - can be used in corrosive applications with appropriate bearings.
- Precision Ball Bearings.
- Temperature Range: -40°F to +270°F.

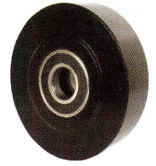

Part Number Swivel Caster	Part Number Rigid Caster	Wheel Diameter (inch)	Tread Width (inch)	Load Capacity (lbs)	Overall Height (inch)	Swivel Radius (inch)	Precision Bearing
4HS42NYMD	4HR42NYMD	4	2	2000	5-5/8	3-3/16	38
4HS52NYMD	4HR52NYMD	5	2	2000	6-1/2	3-7/8	38
4HS62NYMD	4HR62NYMD	6	2	2000	7-1/2	4-9/16	38
4HS82NYMD	4HR82NYMD	8	2	2000	9-1/2	6	38

PTU WHEELS

HI-TECH POLYURETHANE ON POLYOLEFIN

- 90-95 Durometer Shore (A) Ductile Polyurethane tread mechanically bonded to Polyolefin core.
- High capacity and lightweight.
- Resists oil, grease, water, and most solvents.

- Smooth rolling and quiet.
- Temp Range: -45°F to +180°F.
- Roller Bearing.

Options

- Donut Tread PTU (6", 8") DTU.



Part Number Swivel Caster	Part Number Rigid Caster	Wheel Diameter (inch)	Tread Width (inch)	Load Capacity (lbs)	Overall Height (inch)	Swivel Radius (inch)	Precision Bearing
4HS42PTU	4HR42PTU	4	2	700	5-5/8	3-1/8	38
4HS52PTU	4HR52PTU	5	2	1000	6-1/2	3-3/4	38
4HS62PTU	4HR62PTU	6	2	1200	7-1/2	4-1/2	38
4HS82PTU	4HR82PTU	8	2	1400	9-1/2	6-5/16	38

HU WHEELS

HEAVY DUTY SOLID POLYURETHANE WHEEL ON GLASS-FILLED NYLON

- 70 Shore (D) durometer.
- FDA standards for use in food processing environments.
- 100% Washable.

- Glass-filled nylon core insert endures heat.
- High impact and abrasion resistant.
- Resists oil, grease, water, and most solvents.
- Temp Range: -50°F to +180°F.
- Precision Ball Bearing.



Part Number Swivel Caster	Part Number Rigid Caster	Wheel Diameter (inch)	Tread Width (inch)	Load Capacity (lbs)	Overall Height (inch)	Swivel Radius (inch)	Precision Bearing
4HS42HU	4HR42HU	4	2	1500	5-5/8	3-1/8	63
4HS52HU	4HR52HU	5	2	1800	6-1/2	3-3/4	63
4HS62HU	4HR62HU	6	2	2000	7-1/2	4-1/2	63
4HS82HU	4HR82HU	8	2	2000	9-1/2	6-5/16	63

DS WHEELS

DUCTILE STEEL

- Extreme heavy duty applications.
- High capacity.
- Effortless rolling under heavy loads.

- Temp Range: -45°F to +800°F.
- Roller Bearing.
- For V Groove change DS to DVG.

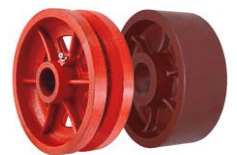

Part Number Swivel Caster	Part Number Rigid Caster	Wheel Diameter (inch)	Tread Width (inch)	Load Capacity (lbs)	Overall Height (inch)	Swivel Radius (inch)	Precision Bearing
4HS42DS	4HR42DS	4	2	1200	5-5/8	3-1/8	38
4HS52DS	4HR52DS	5	2	1500	6-1/2	3-3/4	38
4HS62DS	4HR62DS	6	2	2000	7-1/2	4-1/2	38
4HS82DS	4HR82DS	8	2	2000	9-1/2	6-5/16	38

4

4H HYBRID KINGPIN CASTERS

SPU
WHEELS

SOLID POLYURETHANE

- 60 Durometer Shore (D).
- FDA requirements met for use in food processing environments.
- 100% Washable.

- One piece mold design eliminates bonding failure.
- High impact and abrasion resistant.
- Resists oil, grease, water, and most solvents.
- Temp Range: -45°F to +180°F.
- Precision Bearings.



Part Number Swivel Caster	Part Number Rigid Caster	Wheel Diameter (inch)	Tread Width (inch)	Load Capacity (lbs)	Overall Height (inch)	Swivel Radius (inch)	Precision Bearing
4HS42SPU	4HR42SPU	4	2	700	5-5/8	3-1/8	63
4HS52SPU	4HR52SPU	5	2	1200	6-1/2	3-3/4	63
4HS62SPU	4HR62SPU	6	2	1200	7-1/2	4-1/2	63
4HS82SPU	4HR82SPU	8	2	1400	9-1/2	6-5/16	63

ERN
WHEELS

ELASTIC RUBBER ON NYLON

- 70-75 Durometer Shore (A).
- Elastic rubber molded to nylon core.
- Non-marking.

- Easy rolling, impact resistant and shock absorbing.
- Temp Range: -40°F to +160°F.
- Precision Bearings.



Part Number Swivel Caster	Part Number Rigid Caster	Wheel Diameter (inch)	Tread Width (inch)	Load Capacity (lbs)	Overall Height (inch)	Swivel Radius (inch)	Precision Bearing
4HS42ERN	4HR42SPU	4	2	325	5-5/8	3-1/8	38
4HS52ERN	4HR52SPU	5	2	475	6-1/2	3-3/4	38
4HS62ERN	4HR62SPU	6	2	500	7-1/2	4-1/2	38
4HS82ERN	4HR82SPU	8	2	600	9-1/2	6-5/16	38

MU/MX
WHEELS

POLYURETHANE ON GLASS-FILLED NYLON

- MU: 10mm thick polyurethane tread.
- MX: 23mm thick polyurethane tread.
- 90-95 Durometer Shore (A) (Green Tread).
- 60-70 Durometer Shore (D) (Moron or Blue Tread).
- Light weight reinforced glass-filled nylon core.

- Non-marking, non-staining, non-conductive tread.
- Floor protective.
- Resists oil, grease, water, and most solvents.
- Temp Range: -45°F to +180°F.
- Roller Bearings.



Part Number Swivel Caster	Part Number Rigid Caster	Wheel Diameter (inch)	Tread Width (inch)	Load Capacity (lbs)	Overall Height (inch)	Swivel Radius (inch)	Precision Bearing
4HS42MU	4HR42MU	4	2	800	5-5/8	3-1/8	63
4HS52MU	4HR52MU	5	2	1400	6-1/2	3-3/4	63
4HS62MU	4HR62MU	6	2	1400	7-1/2	4-1/2	63
4HS82MU	4HR82MU	8	2	1800	9-1/2	6-5/16	63

4 4H HYBRID KINGPIN CASTERS

TUA WHEELS

POLYURETHANE ON ALUMINUM FLAT TREAD

- High Tech grade polyurethane tread.
- 85 Durometer Shore (A) deflects debris.
- Non-marking and rolls effortlessly.
- Multi-year tread durability.
- Temp Range: -40°F to +180°F.
- Precision Bearings.

Part Number Swivel Caster	Part Number Rigid Caster	Wheel Diameter (inch)	Tread Width (inch)	Load Capacity (lbs)	Overall Height (inch)	Swivel Radius (inch)	Precision Bearing
4HS52TUA	4HR52TUA	5	2	1500	7-1/2	4-1/2	63
4HS62TUA	4HR62TUA	6	2	2000	9-1/2	6-5/16	63
4HS82TUA	4HR82TUA	8	2	2000	9-1/2	6-5/16	64



DUA WHEELS

POLYURETHANE ON ALUMINUM DONUT TREAD

- High Tech grade polyurethane tread.
- 85 Durometer Shore (A) deflects debris.
- Non-marking and rolls effortlessly.
- Multi-year tread durability.
- Temp Range: -40°F to +180°F.
- Temp Range: -40°F to +180°F.

Part Number Swivel Caster	Part Number Rigid Caster	Wheel Diameter (inch)	Tread Width (inch)	Load Capacity (lbs)	Overall Height (inch)	Swivel Radius (inch)	Precision Bearing
4HS42DUA	4HR42DUA	4	2	1000	5-5/8	3-1/8	63
4HS52DUA	4HR52DUA	5	2	1200	6-1/2	3-3/4	63
4HS62DUA	4HR62DUA	6	2	1500	7-1/2	4-1/2	63
4HS82DUA	4HR82DUA	8	2	2000	9-1/2	6-5/16	63

MA/TMA WHEELS

GLASS-FILLED NYLON

- 85 Durometer Shore (A).
- Impervious to most chemicals, solvents, oil, salt, alkalines and water.
- Use metal only bearing components for temperatures over 180°F.
- Hi Temp: +490°F continuous, +550°F intermittent (part #TMA).
- Roller Bearings.

Part Number Swivel Caster	Part Number Rigid Caster	Wheel Diameter (inch)	Tread Width (inch)	Load Capacity (lbs)	Overall Height (inch)	Swivel Radius (inch)	Precision Bearing
4HS42MA	4HR42MA	4	2	800	5-5/8	3-1/8	38
4HS52MA	4HR52MA	5	2	1000	6-1/2	3-3/4	38
4HS62MA	4HR62MA	6	2	1200	7-1/2	4-1/2	38
4HS82MA	4HR82MA	8	2	1400	9-1/2	6-5/16	38



PPU WHEELS

POLYURETHANE ON POLYOLEFIN

- Injection Molded Polyurethane Tread mechanically bonded to polyolefin core.
- 90-95 Durometer Shore (A) Polyurethane Tread mechanically bonded to polyolefin core.
- High capacity and lightweight.
- Resist oil, grease, water and most solvents.
- Smooth rolling and quiet.
- Non-marking.
- Temp Range: -45°F to +180°F.
- Roller Bearings.

Part Number Swivel Caster	Part Number Rigid Caster	Wheel Diameter (inch)	Tread Width (inch)	Load Capacity (lbs)	Overall Height (inch)	Swivel Radius (inch)	Precision Bearing
4HS42PPU	4HR42PPU	4	2	700	5-5/8	3-1/8	38
4HS52PPU	4HR52PPU	5	2	750	6-1/2	3-3/4	38
4HS62PPU	4HR62PPU	6	2	900	7-1/2	4-1/2	38
4HS82PPU	4HR82PPU	8	2	1000	9-1/2	6-5/16	38



4 4D KINGPIN CASTERS



**FOOT OPERATED
SWIVEL LOCK
4PSL27**



**Specify Toe Guard
TO**

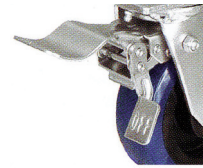

**DUAL PEDAL
TOTAL LOCK
DT**

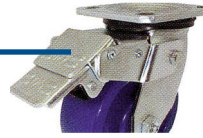
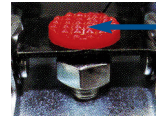

**FRONT DUAL PEDAL
ADJUSTABLE TOTAL
LOCKING CASTERS
FT**



**TECH-LOCK
PEDAL BRAKE
H**

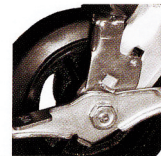

**TOP-LOCK
BRAKE
T**



**RACEWAY SEALS
Thermo - plastic
up to 140° F
L**

1,250 LBS. LOAD CAPACITY FORGED KINGPIN TYPE CASTERS

- Double ball raceway offer smooth swiveling action, strength and long service life.
- Standard 5/8" nut & bolt Kingpin.
- 1/4" thick cold rolled steel; designed, formed and welded for optimal mobility.

- Zinc plated finish is attractive & corrosion resistant.
- Zerk grease fitting in raceway & axle for maintenance.

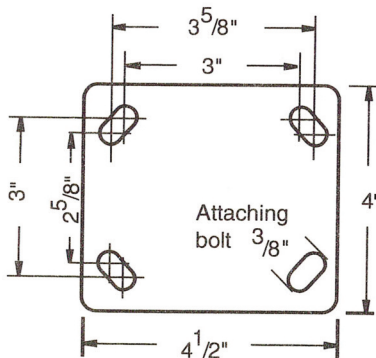

**STANDARD TOP PLATE
4 X 4-1/2**

**BOLT HOLE CENTER
2-5/8 X 3-5/8
SLOTTED TO 3 X 3**

**ATTACHING BOLT SIZE
3/8**

**OPTIONAL TOP PLATE 20
5 X 5-1/2**

**BOLT HOLE CENTER
4-1/8 X 4-1/2**

**ATTACHING BOLT SIZE
3/8**

**ALL WHEELS
AVAILABLE WITH
ROLLER BEARINGS
OR
DELRIN BUSHING**

4 4D KINGPIN CASTERS

MU WHEELS

POLYON MAXROK™

- Polyurethane elastomer tread chemically bonded on glass filled nylon core.
- Offers a smooth effortless ride, is non-marking and protects floors.
- Resist compression set or “flat spotting,” has exceptional impact strength and good abrasion resistance.

- Non-metal materials will not rust.
- Color: green.
- Durometer: 95 Shore A +/-5.
- Temp Range: -45°F to +180°F.
- Roller Bearings.



Part Number Swivel Caster	Part Number Swivel with Total Lock	Part Number Rigid Caster	Wheel Diameter (inch)	Tread Width (inch)	Load Capacity (lbs)	Overall Height (inch)	Swivel Radius (inch)	Swivel Radius w/Total Lock (inch)	Swivel Radius w/Wheel Brake (inch)
4DS42MU	4DTL42MU	4DR42MU	4	2	700	5-5/8	3-3/16	4	8-1/2
4DS52MU	4DTL52MU	4DR52MU	5	2	1000	6-1/2	3-7/8	4	9-1/2
4DS62MU	4DTL62MU	4DR62MU	6	2	1200	7-1/2	4-9/16	6	10
4DS82MU	4DTL82MU	4DR82MU	8	2	1250	9-1/2	6	6	11-1/2

PM WHEELS

POLYADIC™

- High performance UV resistant, liquid cast polyurethane elastomer; mechanically locked onto an injection molded polyolefin core; takes more abuse and has a longer service life than standard PP wheels.
- 1-1/4” wide wheels are maroon or gray, with sanitary style (no thread guards) dished out core and dual row annular ball bearings, offering improved mobility and stability.

- Axle can be completely tightened without binding the bearings. 2” wide wheels have a dark gray tread on a gray core.
- Durometer: 60 Shore D +/-5.
- Temp Range: -45°F to +180°F.
- Precision Bearings.



Part Number Swivel Caster	Part Number Swivel with Total Lock	Part Number Rigid Caster	Wheel Diameter (inch)	Tread Width (inch)	Load Capacity (lbs)	Overall Height (inch)	Swivel Radius (inch)	Swivel Radius w/Total Lock (inch)	Swivel Radius w/Wheel Brake (inch)
4DS42PM	4DTL42PM	4DR42PM	4	2	600	5-5/8	3-3/16	4	8-1/2
4DS52PM	4DTL52PM	4DR52PM	5	2	750	6-1/2	3-7/8	4	9-1/2
4DS62PM	4DTL62PM	4DR62PM	6	2	900	7-1/2	4-9/16	6	10
4DS82PM	4DTL82PM	4DR82PM	8	2	1000	9-1/2	6	6	11-1/2

HU WHEELS

ERGOLASTOMER™

- Super strength solid cast polyurethane elastomer one piece design with mechanically locked glass filled nylon bearing collar, offers the best durability and performance of any elastomer type wheel on the market.
- Precision Ball Bearings.
- 100% washable, steam cleanable, chemical resistant.

- Extreme impact strength and abrasion and compression resistance, will not flat spot when used within capacity rating.
- Offers a smooth ergonomic ride; easy start up.
- Color: grey with black core/bearing collar.
- Durometer: 68 Shore D +/-5.
- Temp Range: -50°F to +180°F.



Part Number Swivel Caster	Part Number Swivel with Total Lock	Part Number Rigid Caster	Wheel Diameter (inch)	Tread Width (inch)	Load Capacity (lbs)	Overall Height (inch)	Swivel Radius (inch)	Swivel Radius w/Total Lock (inch)	Swivel Radius w/Wheel Brake (inch)
4DS42HU	4DTL42HU	4DR42HU	4	2	1000	5-5/8	3-3/16	4	8-1/2
4DS52HU	4DTL52HU	4DR52HU	5	2	1250	6-1/2	3-7/8	4	9-1/2
4DS62HU	4DTL62HU	4DR62HU	6	2	1250	7-1/2	4-9/16	6	10
4DS82HU	4DTL82HU	4DR82HU	8	2	1250	9-1/2	6	6	11-1/2

4 4D KINGPIN CASTERS

SU WHEELS

DURALASTOMER™

- Solid cast polyurethane elastomer one piece design eliminates bonding failures and is a very reliable and durable wheel.
- 100% washable & steam cleanable; not affected by grease, oils, most chemicals & cleaning solutions, brine and blood.
- Flanged Precision Ball Bearings.

- Offers a smooth effortless ride, is non-marking and protects floors.
- Resists compression set or “flat spotting,” has exceptional impact strength and is highly abrasion resistant.
- Color: blue.
- Durometer: 60 Shore D +/-5.
- Temp Range: -50°F to +180°F.



Part Number Swivel Caster	Part Number Swivel with Total Lock	Part Number Rigid Caster	Wheel Diameter (inch)	Tread Width (inch)	Load Capacity (lbs)	Overall Height (inch)	Swivel Radius (inch)	Swivel Radius w/Total Lock (inch)	Swivel Radius w/Wheel Brake (inch)
4DS42SU	4DTL42SU	4DR42SU	4	2	750	5-5/8	3-3/16	4	8-1/2
4DS52SU	4DTL52SU	4DR52SU	5	2	900	6-1/2	3-7/8	4	9-1/2
4DS62SU	4DTL62SU	4DR62SU	6	2	1000	7-1/2	4-9/16	6	10
4DS82SU	4DTL82SU	4DR82SU	8	2	1000	9-1/2	6	6	11-1/2

TPR WHEELS

THERMO-PRO™ RUBBER CROWN TREAD ON POLYOLEFIN CORE.

- Non-marking thermoplastic rubber tread is permanently bonded to polyolefin core.
- Shock absorbing cushioned ride offers floor protection and quiet rolling operation.
- Offers good stability at low temperatures.
- Resistant to cleaning chemicals, acids, alcohol, water, and is excellent for wash down applications & outdoor use, UV resistant.

- Offers a smooth effortless ride, is non-marking and protects floors.
- Rolling Bearing.
- Color: gray or black tread.
- Durometer: 75 Shore A +/-5.
- Temp Range: -40°F to +180°F.



Part Number Swivel Caster	Part Number Swivel with Total Lock	Part Number Rigid Caster	Wheel Diameter (inch)	Tread Width (inch)	Load Capacity (lbs)	Overall Height (inch)	Swivel Radius (inch)	Swivel Radius w/Total Lock (inch)	Swivel Radius w/Wheel Brake (inch)
4DS42TPR	4DTL42TPR	4DR42TPR	4	2	300	5-5/8	3-3/16	4	8-1/2
4DS52TPR	4DTL52TPR	4DR52TPR	5	2	350	6-1/2	3-7/8	4	9-1/2
4DS62TPR	4DTL62TPR	4DR62TPR	6	2	500	7-1/2	4-9/16	6	10
4DS82TPR	4DTL82TPR	4DR82TPR	8	2	600	9-1/2	6	6	11-1/2

TPF WHEELS

THERMO-PRO™ RUBBER FLAT TREAD ON POLYOLEFIN CORE.

- Non-marking thermoplastic rubber tread is permanently bonded to polyolefin core.
- Shock absorbing cushioned ride offers floor protection and quiet rolling operation.
- Offers good stability at low temperatures.
- Resistant to cleaning chemicals, acids, alcohol, water, and is excellent for wash down applications & outdoor use, UV resistant.

- Offers a smooth effortless ride, is non-marking and protects floors.
- Flat tread wheels offer maximum durability at rated capacities; while round tread wheels offer an easy rolling ergonomic ride; reduced tread surface area also enables improved swiveling capabilities and turning mobility.
- Color: gray or black tread.
- Durometer: 75 Shore A +/-5.
- Temp Range: -40°F to +180°F.



Part Number Swivel Caster	Part Number Swivel with Total Lock	Part Number Rigid Caster	Wheel Diameter (inch)	Tread Width (inch)	Load Capacity (lbs)	Overall Height (inch)	Swivel Radius (inch)	Swivel Radius w/Total Lock (inch)	Swivel Radius w/Wheel Brake (inch)
4DS42TPF	4DTL42TPF	4DR42TPF	4	2	300	5-5/8	3-3/16	4	8-1/2
4DS52TPF	4DTL52TPF	4DR52TPF	5	2	350	6-1/2	3-7/8	4	9-1/2
4DS62TPF	4DTL62TPF	4DR62TPF	6	2	500	7-1/2	4-9/16	6	10
4DS82TPF	4DTL82TPF	4DR82TPF	8	2	600	9-1/2	6	6	11-1/2

4 4D KINGPIN CASTERS

RA WHEELS RUBBER ON ALUMINUM

- Rubber tread vulcanized to aluminum core.
- Offer shock absorbing cushioned ride, rolls over debris, offers floor protection & quiet rolling operation.

- Aluminum core has a strong attractive appearance, is lightweight and is resistant to rust and corrosion.
- Color: gray or black tread.
- Durometer: 80 Shore A +/-5.
- Temp Range: -40°F to +160°F.
- Roller Bearing.



Part Number Swivel Caster	Part Number Swivel with Total Lock	Part Number Rigid Caster	Wheel Diameter (inch)	Tread Width (inch)	Load Capacity (lbs)	Overall Height (inch)	Swivel Radius (inch)	Swivel Radius w/Total Lock (inch)	Swivel Radius w/Wheel Brake (inch)
4DS42RA	4DTL42RA	4DR42RA	4	2	400	5-5/8	3-3/16	4	8-1/2
4DS52RA	4DTL52RA	4DR52RA	5	2	500	6-1/2	3-7/8	4	9-1/2
4DS62RA	4DTL62RA	4DR62RA	6	2	550	7-1/2	4-9/16	6	10

NR WHEELS RUBBER ON NYLON

- Soft rubber tread is molded over hard rubber core.
- Shock absorbing cushioned ride and offers floor protection & quiet rolling operation.
- Nylon bearing sleeve molded into wheel core, offers improved rollability.

- Precision Ball Bearing Flanged.
- Color: black.
- Durometer: 80 Shore A +/-5.
- Temp Range: -40°F to +180°F.
- Roller Bearing.



Part Number Swivel Caster	Part Number Swivel with Total Lock	Part Number Rigid Caster	Wheel Diameter (inch)	Tread Width (inch)	Load Capacity (lbs)	Overall Height (inch)	Swivel Radius (inch)	Swivel Radius w/Total Lock (inch)	Swivel Radius w/Wheel Brake (inch)
4DS42NR	4DTL42NR	4DR42NR	4	2	400	5-5/8	3-3/16	4	8-1/2
4DS52NR	4DTL52NR	4DR52NR	5	2	450	6-1/2	3-7/8	4	9-1/2
4DS62NR	4DTL62NR	4DR62NR	6	2	550	7-1/2	4-9/16	6	10
4DS82NR	4DTL82NR	4DR82NR	8	2	600	9-1/2	6	6	11-1/2

PU WHEELS POLYON™

- Polyurethane elastomer tread chemically bonded to cast iron core.
- Offers higher weight capacities while providing good floor protection and quiet rolling operation.
- Sealed Precision Ball Bearing with Top Hats.

- Works well in both indoor and outdoor environments; however cast iron core can rust; if this is an issue, look at using aluminum wheels.
- Color: red & green.
- Durometer: 95 Shore A +/-5.
- Temp Range: -40°F to +180°F.

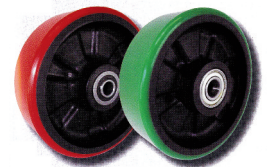

Part Number Swivel Caster	Part Number Swivel with Total Lock	Part Number Rigid Caster	Wheel Diameter (inch)	Tread Width (inch)	Load Capacity (lbs)	Overall Height (inch)	Swivel Radius (inch)	Swivel Radius w/Total Lock (inch)	Swivel Radius w/Wheel Brake (inch)
4DS42PU	4DTL42PU	4DR42PU	4	2	450	5-5/8	3-3/16	4	8-1/2
4DS52PU	4DTL52PU	4DR52PU	5	2	500	6-1/2	3-7/8	4	9-1/2
4DS62PU	4DTL62PU	4DR62PU	6	2	600	7-1/2	4-9/16	6	10
4DS82PU	4DTL82PU	4DR82PU	8	2	700	9-1/2	6	6	11-1/2

4 4D KINGPIN CASTERS

PO WHEELS

POLYOLEFIN

- Solid injection molded polyolefin wheel construction.
- High shock load, impact & abrasion resistant.
- Economical & lightweight, yet offer high weight capacities.
- Sealed Precision Ball Bearing Flanged.

- 100% washable; impervious to water, highly resistant to organic solvents, oil, grease, most chemicals, acids & cleaning solutions.
- Color: black or white tread.
- Durometer: 70 Shore D +/-5.
- Temp Range: -40°F to +180°F.



Part Number Swivel Caster	Part Number Swivel with Total Lock	Part Number Rigid Caster	Wheel Diameter (inch)	Tread Width (inch)	Load Capacity (lbs)	Overall Height (inch)	Swivel Radius (inch)	Swivel Radius w/Total Lock (inch)	Swivel Radius w/Wheel Brake (inch)
4DS42PO	4DTL42PO	4DR42PO	4	2	700	5-5/8	3-3/16	4	8-1/2
4DS52PO	4DTL52PO	4DR52PO	5	2	900	6-1/2	3-7/8	4	9-1/2
4DS62PO	4DTL62PO	4DR62PO	6	2	1000	7-1/2	4-9/16	6	10
4DS82PO	4DTL82PO	4DR82PO	8	2	1200	9-1/2	6	6	11-1/2

PA/PR WHEELS

POLYON-AL™

- Polyurethane elastomer tread chemically bonded to a aluminum core.
- Aluminum core has a strong attractive appearance, is lightweight and is resistant to rust and corrosion.
- Sealed Precision Ball Bearing Flanged.

- 100% washable; impervious to water, highly resistant to organic solvents, oil, grease, most chemicals, acids & cleaning solutions.
- Color: red, green & blue.
- Durometer: 95 Shore A +/-5.
- Temp Range: -40°F to +180°F.

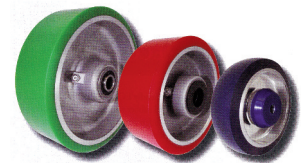

Part Number Swivel Caster	Part Number Swivel with Total Lock	Part Number Rigid Caster	Wheel Diameter (inch)	Tread Width (inch)	Load Capacity (lbs)	Overall Height (inch)	Swivel Radius (inch)	Swivel Radius w/Total Lock (inch)	Swivel Radius w/Wheel Brake (inch)
4DS42PA	4DTL42PA	4DR42PA	4	2	800	5-5/8	3-3/16	4	8-1/2
4DS52PA	4DTL52PA	4DR52PA	5	2	900	6-1/2	3-7/8	4	9-1/2
4DS62PA	4DTL62PA	4DR62PA	6	2	1200	7-1/2	4-9/16	6	10
4DS82PA	4DTL82PA	4DR82PA	8	2	1250	9-1/2	6	6	11-1/2

MA WHEELS

MAXROK™

- Injection molded, 30% glass filled nylon wheel; has the same weight capacity of steel, yet incredibly light-weight.
- 100% washable & steam cleanable, not affected by grease, oil, most chemicals & cleaning solutions, salt, brine & blood.
- Sealed Precision Ball Bearing with Top Hat Bushings.

- Extreme impact strength, good abrasion and compression resistance, will not flat spot.
- Offers a smooth ergonomic ride; requires less effort to start up and maintain a rolling load.
- Durometer: 85 Shore D +/-5.
- Temp Range: -40°F to +250°F.



Part Number Swivel Caster	Part Number Swivel with Total Lock	Part Number Rigid Caster	Wheel Diameter (inch)	Tread Width (inch)	Load Capacity (lbs)	Overall Height (inch)	Swivel Radius (inch)	Swivel Radius w/Total Lock (inch)	Swivel Radius w/Wheel Brake (inch)
4DS42MA	4DTL42MA	4DR42MA	4	2	800	5-5/8	3-3/16	4	8-1/2
4DS52MA	4DTL52MA	4DR52MA	5	2	1000	6-1/2	3-7/8	4	9-1/2
4DS62MA	4DTL62MA	4DR62MA	6	2	1200	7-1/2	4-9/16	6	10
4DS82MA	4DTL82MA	4DR82MA	8	2	1250	9-1/2	6	6	11-1/2

4 4D KINGPIN CASTERS

BC WHEELS

DURA-CUSHON™

- High modulus quality rubber tread vulcanized to aluminum core.
- Rounded balloon cushion tread offers the best shock absorbing cushioned ride available, easily rolls over debris and small obstructions (electrical cords, floor joint, etc), offers maximum floor protection, high impact strength and ultra quiet rolling operation.

- Sealed Precision Ball Bearing with Top Hat Bushings.
- High modulus round tread minimizes surface friction and enables wheel to turn easily.
- Gray or black tread colors are available; grey tread is non-marking.
- Durometer: 60 Shore A +/-5.
- Temp Range: -40°F to +180°F.

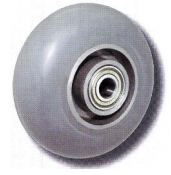

Part Number Swivel Caster	Part Number Swivel with Total Lock	Part Number Rigid Caster	Wheel Diameter (inch)	Tread Width (inch)	Load Capacity (lbs)	Overall Height (inch)	Swivel Radius (inch)	Swivel Radius w/Total Lock (inch)	Swivel Radius w/Wheel Brake (inch)
4DS62BC	4DTL62BC	4DR62BC	6	2	350	7-1/2	4-9/16	6	10
4DS82BC	4DTL82BC	4DR82BC	8	2	450	9-1/2	6	6	11-1/2

UA WHEELS

POLYFLEXON™

- Uniquely formulated “Flex Compound” polyurethane elastomer is chemically and mechanically bonded to a precision aluminum core; double bonding helps prevent tread separation and assures reliable mobility.
- Combination of the round tread and sealed precision ball bearings minimizes surface friction, enables wheel to turn easily and requires less effort to startup and maintain a rolling load.

- Sealed Precision Ball Bearing with Top Hat Bushings.
- Offers a semi-cushioned ride, is non-marking and is capable of rolling over debris (metal shavings, door & floor joints, etc.)
- Great for manual or power assisted (towline) applications.
- Durometer: 85 Shore A +/-5.
- Temp Range: -40°F to +180°F.



Part Number Swivel Caster	Part Number Swivel with Total Lock	Part Number Rigid Caster	Wheel Diameter (inch)	Tread Width (inch)	Load Capacity (lbs)	Overall Height (inch)	Swivel Radius (inch)	Swivel Radius w/Total Lock (inch)	Swivel Radius w/Wheel Brake (inch)
4DS62UA	4DTL62UA	4DR62UA	6	2	900	7-1/2	4-9/16	6	10
4DS82UA	4DTL82UA	4DR82UA	8	2	1000	9-1/2	6	6	11-1/2

CP WHEELS

CHAMPION™

- 1-3/16” thick ultra-flex compound polyurethane elastomer tread chemically bonded to a mag style aluminum core, sets a new standard in high quality wheels; maximizing load capacity, shock load, and vibration stabilization.
- Combination of the thick ultra-flex tread and oversized sealed precision ball bearings minimizes rolling resistance.

- Sealed Precision Ball Bearing with Top Hat Bushings.
- Elastic properties of ultra-flex tread provide excellent abrasion resistance and a cushioned ride that easily rolls over debris and small obstructions. Offers maximum floor protection, high impact strength and ultra quiet rolling operation.
- Great for manual or power assisted applications.
- Color: green.
- Durometer: 70 Shore A +/-5.
- Temp Range: -40°F to +180°F.



Part Number Swivel Caster	Part Number Swivel with Total Lock	Part Number Rigid Caster	Wheel Diameter (inch)	Tread Width (inch)	Load Capacity (lbs)	Overall Height (inch)	Swivel Radius (inch)	Swivel Radius w/Total Lock (inch)	Swivel Radius w/Wheel Brake (inch)
4DS62CP	4DTL62CP	4DR62CP	6	2	1200	7-1/2	4-9/16	6	10
4DS82CP	4DTL82CP	4DR82CP	8	2	1250	9-1/2	6	6	11-1/2

4 4D KINGPIN CASTERS

PH WHEELS

PHENOLIC

- Phenolic resin mixed with macerated canvas; creates a high capacity, high impact resistant wheel that has many years of proven reliability in the industry.
- Hard tread rolls easily, provides good concrete floor protection and is quieter than steel wheels.
- Roller Ball Bearing.

- Resistant to oil, grease & solvents, non-metallic and non-sparking.
- Economically priced wheel.
- Zerk fitting are not standard, but available upon request.
- Durometer: 90 Shore D +/-5.
- Temp Range: -50°F to +250°F.



Part Number Swivel Caster	Part Number Swivel with Total Lock	Part Number Rigid Caster	Wheel Diameter (inch)	Tread Width (inch)	Load Capacity (lbs)	Overall Height (inch)	Swivel Radius (inch)	Swivel Radius w/Total Lock (inch)	Swivel Radius w/Wheel Brake (inch)
4DS32PH	4DTL32PH	4DR32PH	3-1/4	2	700	4-1/4	1-3/4	4	8-1/2
4DS42PH	4DTL42PH	4DR42PH	4	2	800	5-5/8	3-3/16	4	8-1/2
4DS52PH	4DTL52PH	4DR52PH	5	2	1000	6-1/2	3-7/8	4	9-1/2
4DS62PH	4DTL62PH	4DR62PH	6	2	1200	7-1/2	4-9/16	6	10
4DS82PH	4DTL82PH	4DR82PH	8	2	1250	9-1/2	6	6	11-1/2

HI-TEMP PHENOLIC +550°F intermittent (part# TPH)

- Stainless Steel Roller Bearing.

Part Number Swivel Caster	Part Number Swivel with Total Lock	Part Number Rigid Caster	Wheel Diameter (inch)	Tread Width (inch)	Load Capacity (lbs)	Overall Height (inch)	Swivel Radius (inch)	Swivel Radius w/Total Lock (inch)	Swivel Radius w/Wheel Brake (inch)
4DS42TPH	4DTL42TPH	4DR42TPH	4	2	800	5-5/8	3-3/16	4	8-1/2
4DS52TPH	4DTL52TPH	4DR52TPH	5	2	1000	6-1/2	3-7/8	4	9-1/2
4DS62TPH	4DTL62TPH	4DR62TPH	6	2	1200	7-1/2	4-9/16	6	10
4DS82TPH	4DTL82TPH	4DR82TPH	8	2	1250	9-1/2	6	6	11-1/2

NY/MD WHEELS

NYLACRON™ CAST NYLON WHEELS

- Precision Machined from Cast Polyamide Hardness 112-120 Rockwell R.
- Ultimate choice for extremely high load applications to replace metallic wheels.
- Offer very high abrasion resistance and very low rolling resistance under extreme loads.

- Resistant to salt, grease, alcohol and mild acids - can be used in corrosive applications with appropriate bearings.
- Precision Ball Bearings.
- Temperature Range: -40°F to +270°F.

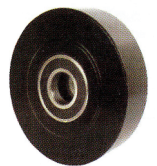

Part Number Swivel Caster	Part Number Swivel with Total Lock	Part Number Rigid Caster	Wheel Diameter (inch)	Tread Width (inch)	Load Capacity (lbs)	Overall Height (inch)	Swivel Radius (inch)	Swivel Radius w/Total Lock (inch)	Swivel Radius w/Wheel Brake (inch)
4DS42NYMD	4DTL42NYMD	4DR42NYMD	4	2	1250	5-5/8	3-3/16	4	8-1/2
4DS52NYMD	4DTL52NYMD	4DR52NYMD	5	2	1250	6-1/2	3-7/8	4	9-1/22
4DS62NYMD	4DTL62NYMD	4DR62NYMD	6	2	1250	7-1/2	4-9/16	6	10
4DS82NYMD	4DTL82NYMD	4DR82NYMD	8	2	1250	9-1/2	6	6	11-1/2

4 4D KINGPIN CASTERS

RP WHEELS

POLYFLEXON™

- Uniquely formulated “Flex Compound” polyurethane elastomer is chemically bonded to heavy cast iron core.
- Combination of the round tread and sealed precision ball bearings minimizes surface friction, enables wheel to turn easily and requires less effort to startup and maintain a rolling load.

- Sealed Precision Ball Bearing with Top Hat Bushings.
- Offers a semi-cushioned ride, is non-marking and is capable of rolling over debris (metal shavings, door & floor joints, etc.)
- Durometer: 80 Shore A +/-5.
- Temp Range: -40°F to +180°F.



Part Number Swivel Caster	Part Number Swivel with Total Lock	Part Number Rigid Caster	Wheel Diameter (inch)	Tread Width (inch)	Load Capacity (lbs)	Overall Height (inch)	Swivel Radius (inch)	Swivel Radius w/Total Lock (inch)	Swivel Radius w/Wheel Brake (inch)
4DS42RP	4DTL42RP	4DR42RP	4	2	700	5-5/8	3-3/16	4	8-1/2
4DS52RP	4DTL52RP	4DR52RP	5	2	800	6-1/2	3-7/8	4	9-1/2
4DS62RP	4DTL62RP	4DR62RP	6	2	900	7-1/2	4-9/16	6	10
4DS82RP	4DTL82RP	4DR82RP	8	2	1000	9-1/2	6	6	11-1/2

RH WHEELS

SUPREME RUBBER

- High quality supreme rubber tread with a tensile strength of 1200 to 1400 PSI, vulcanized to a solid heavy duty cast iron core.
- Upgraded tread material, core design and bearings; provide the perfect combination needed for use on tow lines and other demanding applications that normal mold-on rubber wheels may not be able to withstand.

- Sealed Precision Ball Bearing with Top Hat Bushings.
- Offers a shock absorbing semi-cushioned ride, rolls over small debris, uneven surfaces, cracks floor joints, etc.
- Provides good floor protection and quiet rolling operation.
- Durometer: 75 Shore A +/-5.
- Temp Range: -40°F to +180°F.



Part Number Swivel Caster	Part Number Swivel with Total Lock	Part Number Rigid Caster	Wheel Diameter (inch)	Tread Width (inch)	Load Capacity (lbs)	Overall Height (inch)	Swivel Radius (inch)	Swivel Radius w/Total Lock (inch)	Swivel Radius w/Wheel Brake (inch)
4DS62RH	4DTL62RH	4DR62RH	6	2	700	7-1/2	4-9/16	6	10
4DS82RH	4DTL82RH	4DR82RH	8	2	800	9-1/2	6	6	11-1/2

SW WHEELS

ENERGY SAVER POLYON

- Crowned polyurethane elastomer tread chemically bonded to a solid heavy-duty cast iron core.
- Combination of crowned tread and heavy core, offers higher weight capacities, durability and greater mobility.
- Sealed Precision Ball Bearings.

- Provides good floor protection and quiet rolling operation.
- Color: dark blue on black.
- Durometer: 95 Shore D +/-5.
- Temp Range: -40°F to +180°F.



Part Number Swivel Caster	Part Number Swivel with Total Lock	Part Number Rigid Caster	Wheel Diameter (inch)	Tread Width (inch)	Load Capacity (lbs)	Overall Height (inch)	Swivel Radius (inch)	Swivel Radius w/Total Lock (inch)	Swivel Radius w/Wheel Brake (inch)
4DS62SW	4DTL62SW	4DR62SW	6	2	1250	7-1/2	4-9/16	6	10
4DS82SW	4DTL82SW	4DR82SW	8	2	1250	9-1/2	6	6	11-1/2

4

4DSS KINGPIN STAINLESS STEEL CASTERS



**SWIVEL CASTER AND
TOTAL LOCK STAINLESS STEEL
CASTER WITH KR WHEEL**
Add TL to swivel caster number



**STAINLESS STEEL
FOOT ACTIVATED
SWIVEL LOCK**
MTG81

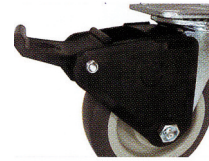

**TECH-LOCK
PEDAL BRAKE**
H

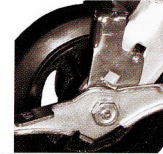

**TOP-LOCK
BRAKE**
T

OPTION RACEWAY SEALS

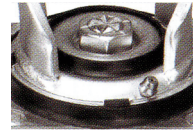

L
Thermo - plastic
up to 140° F



H
H.T. Neoprene
up to 380° F



Specify Toe Guard
TO

1,250 LBS. LOAD CAPACITY STAINLESS STEEL TYPE CASTERS

- All metal parts made from 304 Stainless Steel 100% washable.
- Double Ball Raceway offers smooth swiveling action, strength and long service life.
- Wash down, high temperature autoclavable wheels.
- 1/4" Thick Fork Legs Robotically welded 2 1/2" spacing.
- Kingpin 5/8" nut & bolt.
- 1/2" Wheel axle.
- Stainless Steel Precision Ball Bearings.
- Polished Stainless Steel Rig available add "P".

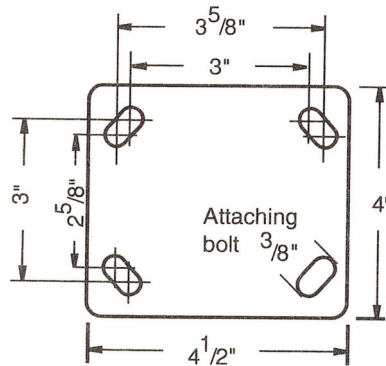

TOP PLATE
4 X 4-1/2

BOLT HOLE CENTER
2-5/8 X 3-5/8
SLOTTED TO
3 X 3

ATTACHING BOLT SIZE
3/8

**ALL WHEELS
AVAILABLE WITH
STAINLESS STEEL
ROLLER BEARINGS
OR
DELTRIN BUSHING**

4

4DSS KINGPIN STAINLESS STEEL CASTERS

NY/MD WHEELS

NYLACRON™ CAST NYLON WHEELS

- Precision Machined from Cast Polyamide Hardness 112-120 Rockwell R.
- Ultimate choice for Extremely High Load applications to replace metallic wheels.
- Offer very high abrasion resistance and very low rolling resistance under extreme loads.

- Resistant to salt, grease, alcohol and mild acids - can be used in corrosive applications with appropriate bearings.
- Stainless Steel Precision Ball Bearings.
- Temperature Range: -40°F to +270°F.

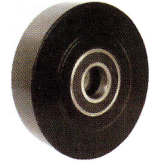

Part Number Swivel Caster	Part Number Swivel with Total Lock	Part Number Rigid Caster	Wheel Diameter (inch)	Tread Width (inch)	Load Capacity (lbs)	Overall Height (inch)	Swivel Radius (inch)	Swivel Radius w/Total Lock (inch)	Swivel Radius w/Wheel Brake (inch)
4DSSS42NYMD	4DSSTL42NYMD	4DSSR42NYMD	4	2	1250	5-5/8	3-3/16	4	8-1/2
4DSSS52NYMD	4DSSTL52NYMD	4DSSR52NYMD	5	2	1250	6-1/2	3-7/8	4	9-1/2
4DSSS62NYMD	4DSSTL62NYMD	4DSSR62NYMD	6	2	1250	7-1/2	4-9/16	6	10
4DSSS82NYMD	4DSSTL82NYMD	4DSSR82NYMD	8	2	1250	9-1/2	6	6	11-1/2

NY/MC WHEELS

NYLACRON™ MONOCAST CAST NYLON WHEELS

- Precision Machined from Cast Polyamide. Hardness 112-120 Rockwell R.
- Ultimate choice for Extremely High Load applications to replace metallic wheels.
- Offer very high abrasion resistance and very low rolling resistance under extreme loads.

- Resistant to salt, grease, alcohol and mild acids - can be used in corrosive applications with appropriate bearings.
- Stainless Steel Precision Ball Bearings.
- Temperature Range: -40°F to +270°F.



Part Number Swivel Caster	Part Number Swivel with Total Lock	Part Number Rigid Caster	Wheel Diameter (inch)	Tread Width (inch)	Load Capacity (lbs)	Overall Height (inch)	Swivel Radius (inch)	Swivel Radius w/Total Lock (inch)	Swivel Radius w/Wheel Brake (inch)
4DSSS42NYMC	4DSSTL42NYMC	4DSSR42NYMC	4	2	1250	5-5/8	3-3/16	4	8-1/2
4DSSS52NYMC	4DSSTL52NYMC	4DSSR52NYMC	5	2	1250	6-1/2	3-7/8	4	9-1/2
4DSSS62NYMC	4DSSTL62NYMC	4DSSR62NYMC	6	2	1250	7-1/2	4-9/16	6	10
4DSSS82NYMC	4DSSTL82NYMC	4DSSR82NYMC	8	2	1250	9-1/2	6	6	11-1/2

NN WHEELS

NYLON WHEELS

- Injection molded from Nylon 6.
- 100% washable & steam cleanable; impervious to water, highly resistant to organic solvents, most chemicals & cleaning solutions; ideal for use in food processing and packaging plants.
- Offer high impact strength and exception abrasion resistance.

- Hard tread has slight crown and rolls very easily.
- Non-marking.
- Durometer: 75 Shore D (+/-5).
- Stainless Steel Precision Ball Bearings.
- Temperature Range: -40°F to +180°F.
- Available in Anti-Static add "AS"



Part Number Swivel Caster	Part Number Swivel with Total Lock	Part Number Rigid Caster	Wheel Diameter (inch)	Tread Width (inch)	Load Capacity (lbs)	Overall Height (inch)	Swivel Radius (inch)	Swivel Radius w/Total Lock (inch)	Swivel Radius w/Wheel Brake (inch)
4DSSS42NN	4DSSTL42NN	4DSSR42NN	4	2	1250	5-5/8	3-3/16	4	8-1/2
4DSSS52NN	4DSSTL52NN	4DSSR52NN	5	2	1250	6-1/2	3-7/8	4	9-1/2
4DSSS62NN	4DSSTL62NN	4DSSR62NN	6	2	1250	7-1/2	4-9/16	6	10
4DSSS82NN	4DSSTL82NN	4DSSR82NN	8	2	1250	9-1/2	6	6	11-1/2

4

4DSS KINGPIN STAINLESS STEEL CASTERS

SS WHEELS

STAINLESS STEEL WHEELS

- Type 304 Stainless Steel.
- Non-magnetic & Non-sparking.
- Excellent corrosion resistance.
- Slightly crowned tread face with rounded corners.

- Stainless Steel Precision Ball Bearings.

- Temperature Range: 800°F.

Custom Stainless Steel Wheels made to your specifications

**V-Groove - VG
Flanged - FL**



Part Number Swivel Caster	Part Number Swivel with Total Lock	Part Number Rigid Caster	Wheel Diameter (inch)	Tread Width (inch)	Load Capacity (lbs)	Overall Height (inch)	Swivel Radius (inch)	Swivel Radius w/Total Lock (inch)	Swivel Radius w/Wheel Brake (inch)
4DSSS42SS	4DSSTL42SS	4DSSR42SS	4	2	1250	5-5/8	3-3/16	4	8-1/2
4DSSS52SS	4DSSTL52SS	4DSSR52SS	5	2	1250	6-1/2	3-7/8	4	9-1/2
4DSSS62SS	4DSSTL62SS	4DSSR62SS	6	2	1250	7-1/2	4-9/16	6	10
4DSSS82SS	4DSSTL82SS	4DSSR82SS	8	2	1250	9-1/2	6	6	11-1/2

SEN WHEELS

SOLID ELASTOMER WHEEL NYLON CORE

- 70 Shore (D) durometer.
- FDA standards for use in food processing environments.
- 100% Washable.

- Glass-filled nylon core insert endures heat.
- High impact and abrasion resistant.
- Resists oil, grease, water, and most solvents.
- Stainless Steel Precision Ball Bearings.
- Temp Range: -50°F to +180°F.



Part Number Swivel Caster	Part Number Swivel with Total Lock	Part Number Rigid Caster	Wheel Diameter (inch)	Tread Width (inch)	Load Capacity (lbs)	Overall Height (inch)	Swivel Radius (inch)	Swivel Radius w/Total Lock (inch)	Swivel Radius w/Wheel Brake (inch)
4DSSS42SEN	4DSSTL42SEN	4DSSR42SEN	4	2	900	5-5/8	3-3/16	4	8-1/2
4DSSS52SEN	4DSSTL52SEN	4DSSR52SEN	5	2	900	6-1/2	3-7/8	4	9-1/2
4DSSS62SEN	4DSSTL62SEN	4DSSR62SEN	6	2	900	7-1/2	4-9/16	6	10
4DSSS72SEN	4DSSTL72SEN	4DSSR72SEN	8	2	900	9-1/2	6	6	11-1/2

KR WHEELS

SOLID POLYURETHANE KRYTONIC™ WHEELS

- Polyether Polyurethane has excellent carrying capacity.
- Crown shape affords an easy-rolling quiet operation.
- Greater service life and resistance to chunking, cutting and abrasive wear.

- 100% washable, steam cleanable, and resistant to most chemicals.
- Non-marking tread.
- Durometer: 58 Shore D (+/-5).
- Stainless Steel Precision Ball Bearings.
- Temperature Range: +250°F for up to 2 hours.



Part Number Swivel Caster	Part Number Swivel with Total Lock	Part Number Rigid Caster	Wheel Diameter (inch)	Tread Width (inch)	Load Capacity (lbs)	Overall Height (inch)	Swivel Radius (inch)	Swivel Radius w/Total Lock (inch)	Swivel Radius w/Wheel Brake (inch)
4DSSS42KR	4DSSTL42KR	4DSSR42KR	4	2	800	5-5/8	3-3/16	4	8-1/2
4DSSS52KR	4DSSTL52KR	4DSSR52KR	5	2	900	6-1/2	3-7/8	4	9-1/2
4DSSS62KR	4DSSTL62KR	4DSSR62KR	6	2	900	7-1/2	4-9/16	6	10
4DSSS72KR	4DSSTL72KR	4DSSR72KR	8	2	900	9-1/2	6	6	11-1/2

OTHER TYPE WHEELS AVAILABLE FOR THIS SERIES:

NYLON FIBERGLASS (NG), NYLACRON™ MD (NY/MD), NYLACRON™ MONOCAST (NY/MC), HIGH TEMP PHENOLIC (TR) AND HEATEATER (HE)
SEE WHEEL SECTION FOR COMPLETE SPECIFICATIONS.

4

4DSS KINGPIN STAINLESS STEEL CASTERS

HE
WHEELS

HI-TEMP NYLON WHEELS

- Ideal for speciality applications.
- Won't chip, absorbs water or breakdown in caustic environments.

- Moderate crown, black finish.
- Durometer: 85 Shore D +5.
- Stainless Steel Rolling Bearings.
- Temperature Range: up to +475°F.



Part Number Swivel Caster	Part Number Swivel with Total Lock	Part Number Rigid Caster	Wheel Diameter (inch)	Tread Width (inch)	Load Capacity (lbs)	Overall Height (inch)	Swivel Radius (inch)	Swivel Radius w/Total Lock (inch)	Swivel Radius w/Wheel Brake (inch)
4DSSS42HE	4DSSTL42HE	4DSSR42HE	4	2	800	5-5/8	3-3/16	4	8-1/2
4DSSS52HE	4DSSTL52HE	4DSSR52HE	5	2	1000	6-1/2	3-7/8	4	9-1/2
4DSSS62HE	4DSSTL62HE	4DSSR62HE	6	2	1200	7-1/2	4-9/16	6	10
4DSSS82HE	4DSSTL82HE	4DSSR82HE	8	2	1250	9-1/2	6	6	11-1/2

RW
WHEELS

RETORT POLYPROPYLENE WHEELS

- Designed to withstand the rigors of high temperature.
- Oversized bore ID ensures smooth movement even if wheels experience heat expansion.

- Moderate crown, white finish.
- Durometer: 75 Shore D.
- Stainless Steel Rolling Bearings.
- Temperature Range: -20°F to +290°F.



Part Number Swivel Caster	Part Number Swivel with Total Lock	Part Number Rigid Caster	Wheel Diameter (inch)	Tread Width (inch)	Load Capacity (lbs)	Overall Height (inch)	Swivel Radius (inch)	Swivel Radius w/Total Lock (inch)	Swivel Radius w/Wheel Brake (inch)
4DSSS42RW	4DSSTL42RW	4DSSR42RW	4	2	500	5-5/8	3-3/16	4	8-1/2
4DSSS52RW	4DSSTL52RW	4DSSR52RW	5	2	1250	6-1/2	3-7/8	4	9-1/2
4DSSS62RW	4DSSTL62RW	4DSSR62RW	6	2	1250	7-1/2	4-9/16	6	10
4DSSS82RW	4DSSTL82RW	4DSSR82RW	8	2	1250	9-1/2	6	6	11-1/2

NG
WHEELS

GLASS FILLED NYLON WHEELS

- Injection molded, 30% glass filled nylon wheel.
- 100% washable & steam cleanable, not affected by grease, oils, most chemicals & cleaning solutions, salt, brine & blood.
- Extreme impact strength, good abrasion and compression resistance.

- Offers a smooth ergonomic ride; requires less effort to start up and maintain a rolling load.
- Durometer: 85 Shore D (+/-5).
- Stainless Steel Pedestal Precision Ball Bearings.
- Temperature Range: -45°F to +250°F up to 3500 F, when used with all metallic bearings and high-temp grease.



Part Number Swivel Caster	Part Number Swivel with Total Lock	Part Number Rigid Caster	Wheel Diameter (inch)	Tread Width (inch)	Load Capacity (lbs)	Overall Height (inch)	Swivel Radius (inch)	Swivel Radius w/Total Lock (inch)	Swivel Radius w/Wheel Brake (inch)
4DSSS42NG	4DSSTL42NG	4DSSR42NG	4	2-3/16	800	5-5/8	3-3/16	4	8-1/2
4DSSS52NG	4DSSTL52NG	4DSSR52NG	5	2-3/16	1000	6-1/2	3-7/8	4	9-1/2
4DSSS62NG	4DSSTL62NG	4DSSR62NG	6	2-3/16	1200	7-1/2	4-9/16	6	10
4DSSS82NG	4DSSTL82NG	4DSSR82NG	8	2-3/16	1250	9-1/2	6	6	11-1/2